

**w.w.Cannon, Inc.**

**Design. Layout. Build. Install.**

1-800-442-3061  
www.wwcannon.com

**PLS**

**Professional Lock Suppliers**

**PLS-ML1200**

**Electromagnetic Lock**

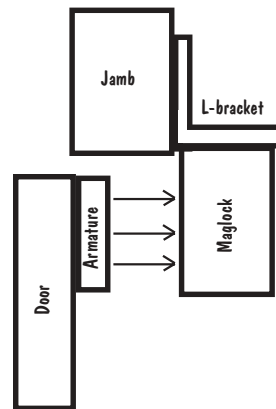


CE

## Installer's Reference Guide

### Function Overview

Power-up turns on the electromagnet, which is attracted to the steel armature plate, which is mounted on a door, holding the door fast against unauthorized entry. When power is turned off, the electromagnet releases the armature plate, allowing the door to open.



### TECHNICAL SPECIFICATIONS

<b>PLS-ML1200</b>	
Power	12VDC / 24VDC
Magnet Size	10.5 x 1.625 x 2.625 in. (268 x 42 x 67 mm)
Armature Size	7.25 x 0.625 x 2.375 in. (185 x 16 x 61 mm)
Holding Force	1200 lb. (545kg)
Current Drain	500mA @ 12VDC; 250mA @ 24VDC
Voltage Tolerance	± 10%
Housing Material	Aluminum
Operating Temperature Limits	14° ~ 131°F (-10° ~ 55°C)
Weight	11 lb. (5.0kg)

## MOUNTING THE PLS-ML1200

- I. Drill holes for the mounting and armature plates (see fig. 1 and 2):
  - A. Fold mounting template on the dotted line.
  - B. Close the door. Locate the mounting location on the door frame near the upper free-moving corner of the door, as close to the corner of the door frame as possible.
  - C. Hold or tape the template against the door and frame.
  - D. Drill two holes in the door frame and three holes in the door, as indicated on the template.

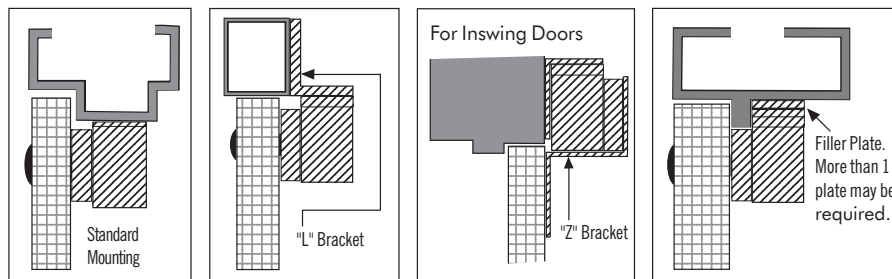
**NOTE:** Filler plate, L-bracket or Z-bracket (optional) may be required for the electromagnet, depending on door frame. See fig. 1.

- II. Mount armature plate to the door using at least two steel and one rubber washer (fig. 2):
 

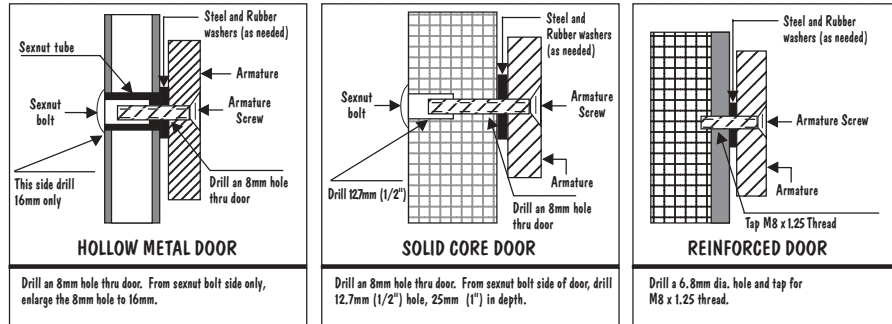
**NOTE:** Actual installation varies according to door type.

- A. Put one rubber washer between two steel washers, and place them over the armature screw between the armature plate and the door. This will allow the armature plate to pivot slightly around the armature screw to compensate for door misalignment.
- B. Tighten the sexnut bolt enough so the armature plate can withstand the force of someone attempting to break down the door while the electromagnet is engaged.

**Fig. 1**

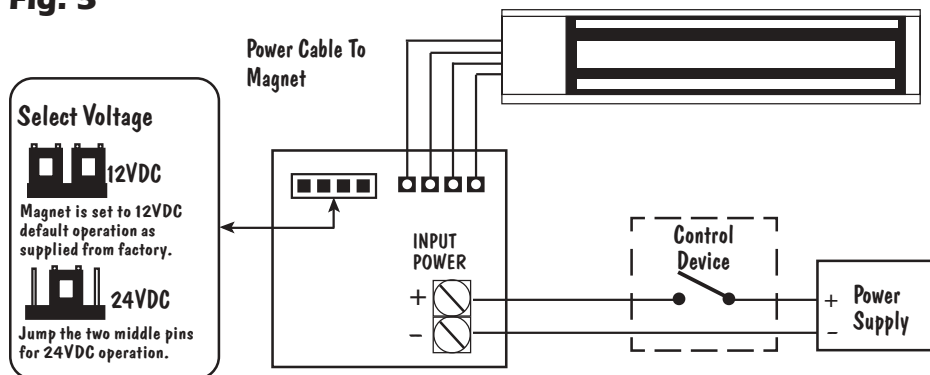


**Fig. 2**



- C. Do not tighten the armature plate against the door. The plate must be able to pivot around the armature screw.
  - D. Make sure the anti-spin guides are in the two guidepin holes.
- III. Screw the mounting plate to the door frame or optional bracket:
- A. Screw the two short self-tapping screws in the slotted holes of the mounting plate and adjust the position of the mounting plate so that it and the armature plate form a 90-degree angle.
  - B. Once the position is correct, use the long self-tapping screws to permanently mount the bracket.
  - C. Remove the two short screws.
- IV. Drill the cable access hole.
- V. Mount the electromagnet to the door frame (fig. 1) — Use the Allen wrench to screw the socket-head mounting screws through the bottom of the electromagnet into the mounting bracket.
- VI. Connect the power leads (fig. 3):
- A. Open the electromagnet.
  - B. Run two power leads from the power supply through the cable access hole into the electromagnet.
  - C. Connect the power leads to the terminal block.
  - D. Close the electromagnet.
- VII. Test the unit.
- VIII. Insert the tamper caps into the mounting screw access holes. This should be the last step, as once the tamper caps are in place, they will be difficult to remove.

**Fig. 3**



**Important:**

Verify correct jumper settings before connecting the lock to the input power. If 24VDC is used with 12VDC setting, then lock may be damaged. If 12VDC is used with 24VDC setting, then lock will have much less holding force.

## TROUBLESHOOTING

<b>Problem:</b>	<b>Possible causes:</b>	<b>Solutions:</b>
The door won't lock	No power	<ul style="list-style-type: none"> <li>• Check to make sure the wires are securely tightened to the terminal block</li> <li>• Check that the power supply is connected and operating</li> <li>• Make sure the lock switch is wired correctly</li> </ul>
The door locks, but can be easily forced open	Electromagnet and armature plate are not making good, close contact	<ul style="list-style-type: none"> <li>• Make sure the electromagnet and armature plate are properly aligned</li> <li>• Make sure the contact surfaces of the electromagnet and armature plate are clean and free from rust</li> </ul>
	Incorrect voltage setting	<ul style="list-style-type: none"> <li>• Check the power leads with a meter, and make sure 12VDC or 24VDC is present and that jumper settings match actual power supply voltage. See Fig. 3.</li> </ul>
Door releases only after a delay	A secondary diode was installed across the electromagnet	<ul style="list-style-type: none"> <li>• The electromagnet comes with a metal oxide varistor built in to prevent interference, so do not install a secondary diode</li> </ul>

## REGULAR MAINTENANCE

- Clean the contact surfaces of the electromagnet or armature plate with a soft cloth and non-abrasive, non-corrosive cleaner.
- Apply a light coat of a silicon lubricant to prevent rust. Wipe away the excess.
- Check that the armature plate is securely attached to the door, yet can pivot slightly around the armature screw.
- Check that the electromagnet is securely attached to the door frame.

**WARRANTY:** PLS Electromagnetic Locks are warranted against defects in material and workmanship while used in normal service for a period of one (1) year from the date of sale to the original customer. Our obligation is limited to the repair or replacement of any defective part if the unit is returned, transportation pre-paid, to PLS.

## NOTICE

The information and specifications printed in this manual are current at the time of publication. However, the PLS policy is one of continual development and improvement. For this reason, PLS reserves the right to change specifications without notice. PLS is also not responsible for misprints or typographical errors.

Copyright © 2003 PLS. All rights reserved. This material may not be reproduced or copied, in whole or in part, without the written permission of PLS.