

db

the quiet fan



With an evenly distributed column of air, the 'DB' is the only high-velocity "quiet fan" on the industrial market today. This innovative, distinctly sleek design requires minimum space, while emulating the performance of our most popular 18" fan, the industry standard in pick module applications. Conceived with distribution and fulfillment centers in mind, this low-profile unit seamlessly combines the need for increased air movement with the noise reduction requirements commonly found in today's modern pick modules. **You asked... we listened... the DB was crafted.**



70% QUIETER 50% MORE CLEARANCE

THE ULTIMATE PICK MODULE FAN

SPECIFICATIONS

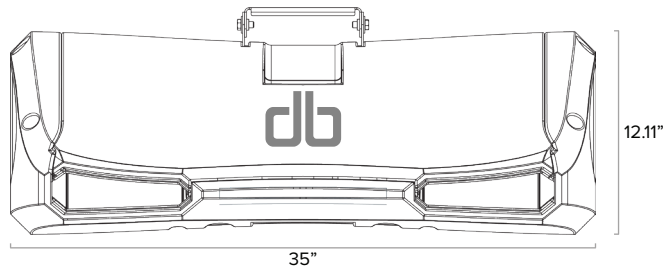
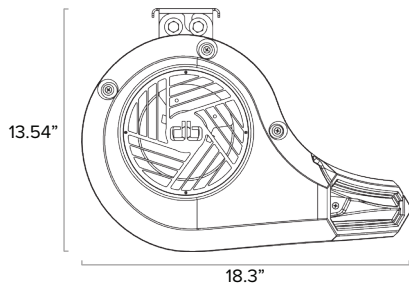

MOTOR	CFM	HP	FAN DIMENSIONS			AIR THROW DISTANCE	SHIPPING WEIGHT
TEAO	2480	1/2	W	D	H	70'	42 lbs
			35"	18.3"	12.1"		

VELOCITY IN FPM

DISTANCE	18" FAN	DB
10'	880	927
20'	649	600
30'	491	530
40'	484	418
50'	394	417

	115V	220V	277V	208-230V	460V
MOTOR AMPS	5.75	2.9	2.5	1.8	0.9
RUNNING AMPS	4.2	1.9	2.1	1	0.5

ONLY **60** DECIBELS

SPACE COMPARISON

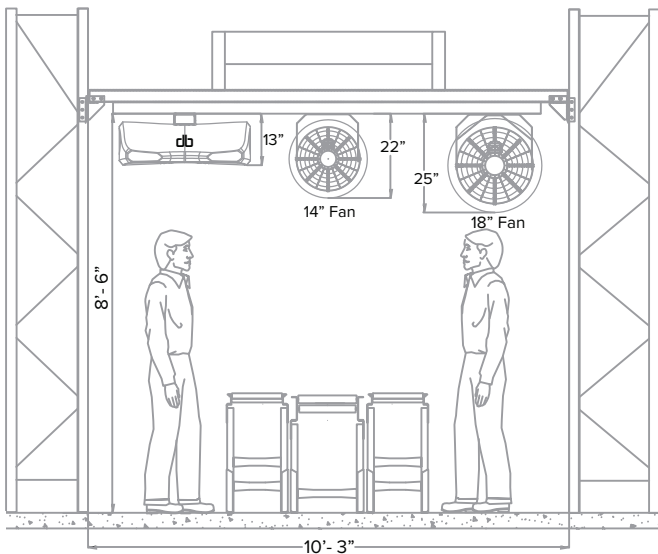

SOUND COMPARISON

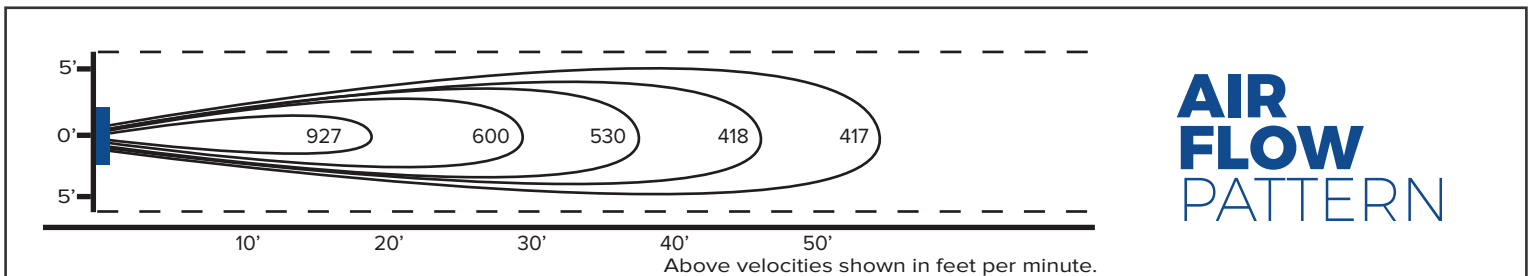
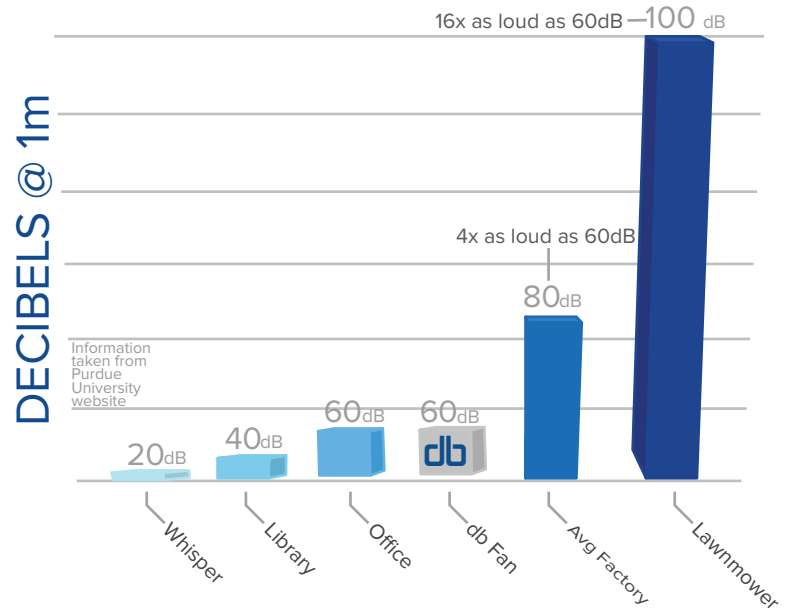

AIR FLOW PATTERN