

LH48

DIRECT DRIVE LIVE HAUL/AGRICULTURAL FAN

Ideal for live haul applications, poultry houses, dairy barns, and greenhouses, the LH48 agricultural panel fan has a robust galvanized steel construction for long-lasting corrosion resistance.

The LH48 features a permanently sealed ball bearing and an ETL-listed, TEAO motor. Each box fan includes mounting holes in the cabinet for hanging options.

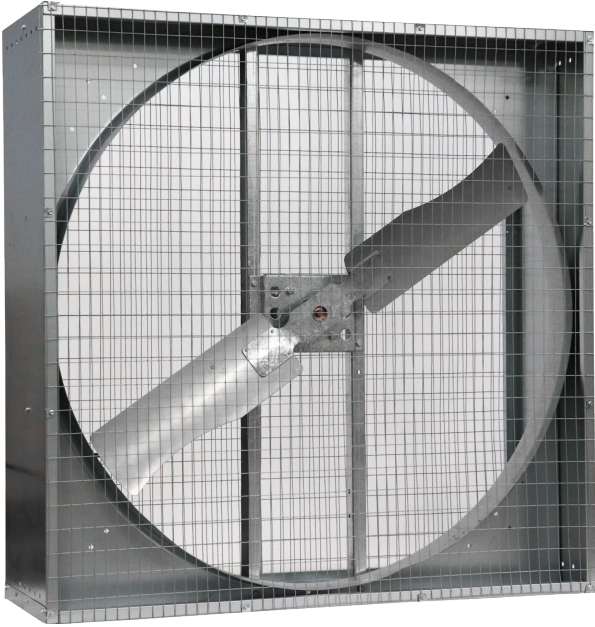

FEATURES APPLICATIONS

- Galvanized steel construction for long-lasting corrosion resistance
- Permanently sealed ball bearings
- ETL-listed, TEAO motor
- Mounting holes on frame
- Ships fully assembled
- Includes 1" x 2" mesh guard
- Live Haul
- Poultry
- Dairy
- Greenhouse

SPECS

MODEL	BLADE DIAMETER	HP	DRIVE	CFM	RPM	VOLTS	AMPS	PHASE	HZ	SHAFT DIAMETER	MAX DB
LH48	48"	1	Direct	19,000	850	230/460	4.6/2.3	3	60	7/8	80

DIMENSIONS

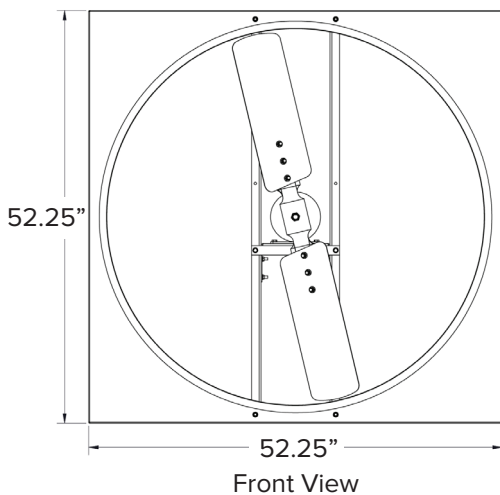

FAN SHROUD ONLY

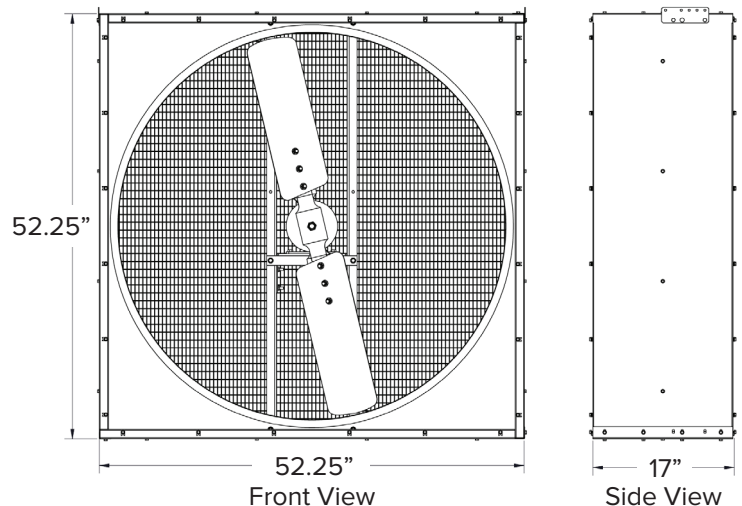

WITH INCLUDED BOX