



BLUE GIANT[®]

HYDRAULIC DOCK LEVELER

LOAD USAGE

Up to 40,000 lb
(18,143 kg)

LOAD CLASS

Workhorse
Heavy
Super
Extreme
Ultra



Designed for demanding applications.
Delivering maximum efficiency and performance.



A
Clean Frame Design
 Allows for easy pit cleaning and reduces trapped debris.

B
One Piece Dock Strut
 Updated design provides increased stability and lessens the likelihood of movement due to vibration.

C
Full Operating Range Toe Guards
 Reduce the risk of foot-related injuries at the loading dock.

D
Solid Structure
 Solid headboard and rear frame enhance unit stability.

E
Enhanced J-Beams Channels
 High-tensile steel beams allow the deck to flex without distorting over time.

F
Fully Hydraulic Operation
 Deck and lip cylinders provide the best in class operation. Full range at the touch of a button.

G
Velocity Fuse
 Reduces fall distance in the event of premature truck departure.

OVERVIEW +FEATURES

EASY TO OPERATE

- Fully hydraulic deck and lip operation eliminates the need for manual deployment.
- The NEMA4X single push-button control station enables sequenced deck and lip operation.
- Maximize unit versatility with optional independent lip control that drastically reduces cycle time and energy use—perfect for below level or end-loading applications (requires Blue Genius™ Touch Control Panel).

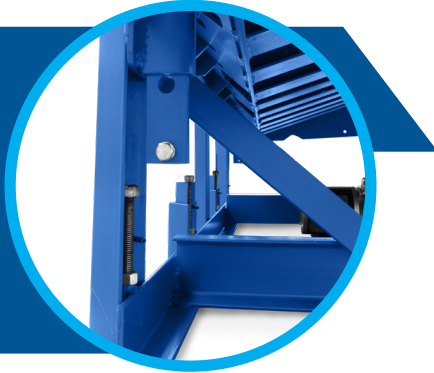

STRUCTURAL INTEGRITY

- 8-10 enhanced J-beam channels are welded to the underside of the deck at dynamic impact points to prevent distortion and extend the lifetime of the dock leveler.
- All dock options, including 6', 6'-6", and 7', are designed to accommodate both four-wheel and three-wheel forklifts as standard.
- The continuous one-piece headboard and single lip hinge pin enhance unit stability, enabling a stronger distributed load.
- Notched headboard and base frame provide increased stability for service equipment, such as the dock strut and service stand.
- High tensile deck and lip provide maximum structural integrity.

DECK FLEX ADVANTAGE

- Ideal for normal loading conditions, the fixed rear hinge design allows the deck to flex up to 4" (102 mm) when under load to ensure full-width contact between the lip and the truck bed.
- The deck remains flush with the floor to eliminate pinch points and cross traffic obstruction.



BUILT FOR SAFETY

- In the unlikely event of premature truck departure, the velocity fuse limits free-fall of a loaded platform to a maximum of 3" (76 mm).
- One piece dock strut settles firmly into vertical position, supporting both deck and lip for safe under-deck maintenance and pit maintenance.
- Optional powder coat grit finish reduces the likelihood of slipping on the deck in wet conditions.
- Stationary side toe guards with high-visibility OSHA safety striping and safety yellow full operating range metal toe guards reduce the risk of foot-related injuries at the loading dock.

ADVANCED ENGINEERING

- The inverted deck cylinder is continually self-bleeding, reducing internal corrosion and improving velocity fuse efficiency.
- The velocity fuse has no limits on performance frequency. Dock operation can resume after the condition that activated the velocity fuse is corrected.
- Equipped with a NEMA4X control station (moisture and corrosion resistant), the Hydraulic Dock Leveler is an ideal solution for special-use facilities, such as refrigerated warehouses and chemical processing plants.
- High tensile J-beams allow the deck to flex side to side while maintaining back to front rigidity without distorting.

INNOVATION AND QUALITY

- An North American industry-first, the Blue Giant Hydraulic Dock Leveler features a powder coat finish as standard, providing unrivaled longevity to finish and color.
- State-of-the-art robotic welding ensures structural integrity and uniform quality.

DESIGN

LEVELER SELECTION - LOAD CLASSIFICATION

TOTAL LOAD

LOAD WEIGHT + VEHICLE WEIGHT

≤ 5MPH

≤ 7% DECK GRADE

DAILY USAGE

FULL TRUCK (FTL) / CYCLES

FULL TRUCK (FTL)	CYCLES
0-8	0-200
9-16	201-400
17-24	401-600
≥ 24	≥ 600

FULL TRUCK = 24-26 PALLETS

LOAD CLASS

LOAD + USAGE

WORKHORSE

HEAVY

SUPER

EXTREME

ULTRA

LOAD USAGE
■ MAX 40,000 LB

To determine your optimal loading dock solution, contact a Blue Giant sales representative with your total load and daily usage data.

PIT DIMENSIONS

NOMINAL SIZE		PIT WIDTH (W)		PIT LENGTH (L)	
		in	mm	in	mm
6' x 6'	1829 x 1829mm	74	1880	63	1600
6' x 8'	1829 x 2438mm			87	2210
6' x 10'	1829 x 3048mm			111	2819
6' 6" x 6'	1981 x 1829mm	80	2032	63	1600
6' 6" x 8'	1981 x 2438mm			87	2210
6' 6" x 10'	1981 x 3048mm			111	2819
7' x 6'	2133 x 1829mm	85	2159	63	1600
7' x 8'	2133 x 2438mm			87	2210
7' x 10'	2133 x 3048mm			111	2819

Standard Pit Depth:
Front (H): 20" (508mm)
Rear (H1): 19.5" (495mm)

Model Number Ordering Format: H - SIZE - CLASS

Sample Order: Hydraulic - 6' x 6' - Workhorse

Sample Model Number: H6006W

COLOUR OPTIONS

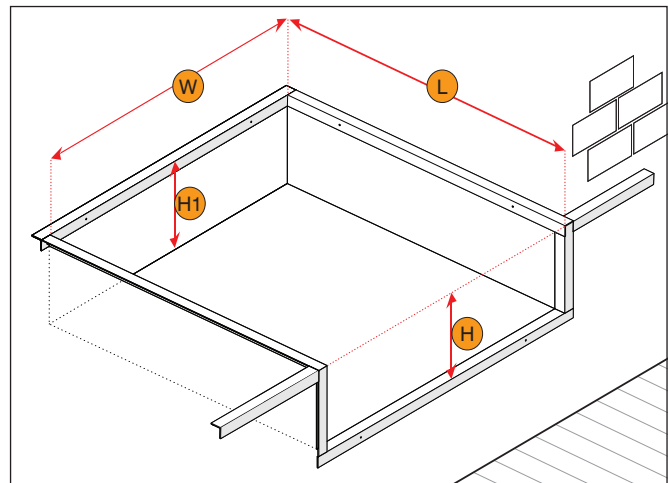
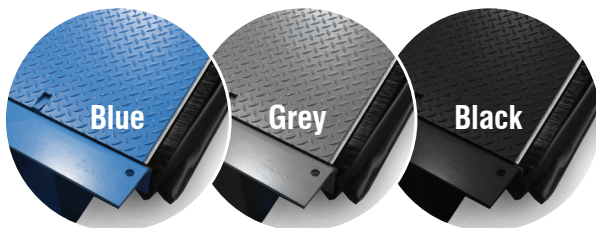

OPTIONS

- Lip Length 16" (406 mm) Standard
18" (457 mm) or 20" (508 mm)
- No-Shim™ dock frame
- Energy Seal Plus™
- Biodegradable oil, Arctic oil
- Assured Motion Float (floating rear hinge)
- Blue Genius™ Touch Control Panel
- Remote Powerpack
- DLB (Dock Lip Barrier)
- Closed Pit Dock Frame
- Grease Fitting on Lip Tube

AUTHORIZED DEALER