



BLUE GIANT®

AFTERMARKET SOLUTIONS



***Brighter than incandescent
or halogen bulbs while
using 80% less energy***

**The Blue Giant LED Loading
Dock Light is a sustainable solution
to the lighting demands of a busy
material handling facility.**

Part # 839-242_HP: 40" Reach, 115V/50-60HZ C/W 9 High-Output 3 Watt LED Bulb

Sustainable Lighting

The LED Loading Dock Light uses only 27 watts of energy, but illuminates the loading dock area with the same clarity as a traditional PAR lamp, which uses 150. The savings of 123 watts per dock light allows facility managers to keep energy costs low without compromising on safety or performance.

Rugged and Lasting Performance

The LED Loading Dock Light represents most durable design in its class. When switched on, it instantly achieves maximum light intensity and the polycarbonate head absorbs heavy impacts from trucks or forklifts without breaking down. Productivity is uninterrupted and the work area remains safely lit.

Complete and Dependable Lighting Package

Comes with nine high-output 3 watt LED bulbs and cage guard, safely illuminating trailer interiors with cool and focused white light. The 40" (1016mm) arm has a double-strut design that provides maximum strength and reliability even in high-activity loading dock environments.

Versatile Application Support

The polycarbonate head remains cool to the touch even after extended usage, ensuring compatibility with refrigerated and food service applications. The double-strut arm enables easy illumination of all truck and trailer types. UL, cUL, and CE listed for safe operation.

LED Loading Dock Light

LED Loading Dock Light

BLUE GIANT[®]
AFTERMARKET SOLUTIONS

View 1

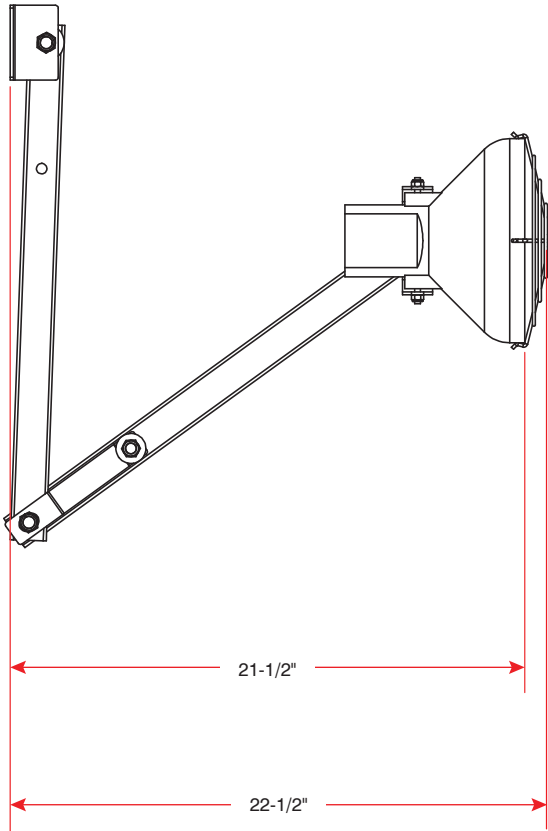

Polycarbonate Lamp Heads

- Indestructible polycarbonate won't dent, bend or break under normal daily use
- Lightweight and shock resistant for longer service life
- Mounts quickly for easy replacement and retrofitting
- Corrosion resistant and non-conductive
- Wire lamp guard included
- Uses R40 bulb – part # 026-725-1

View 3

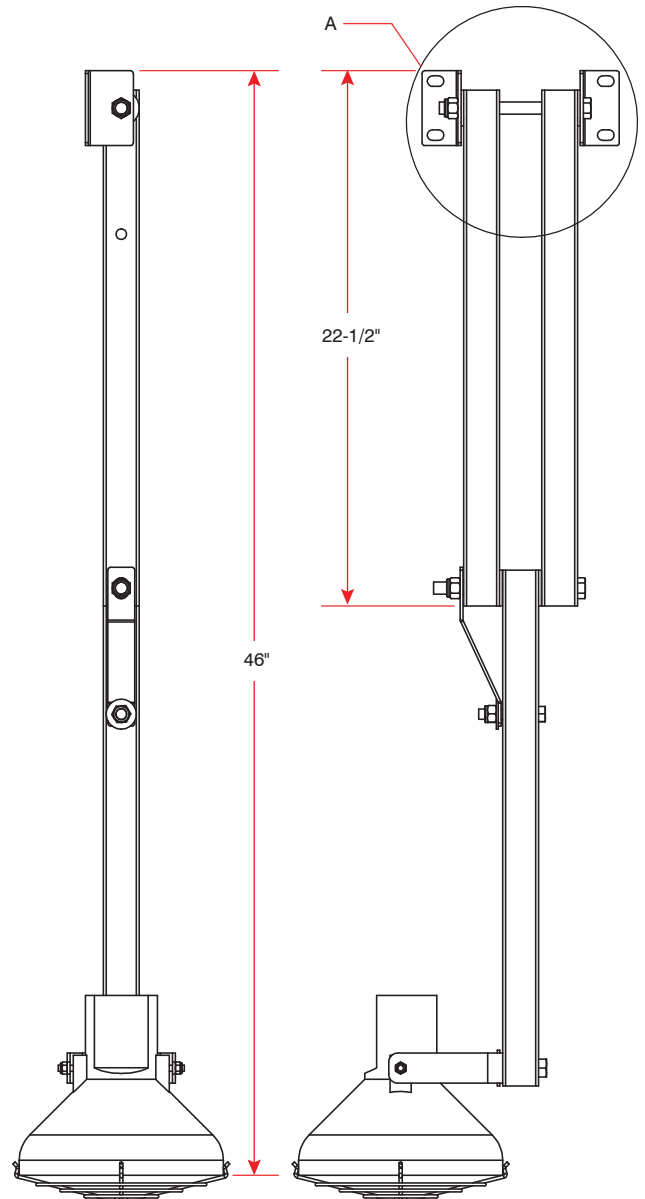

View 2

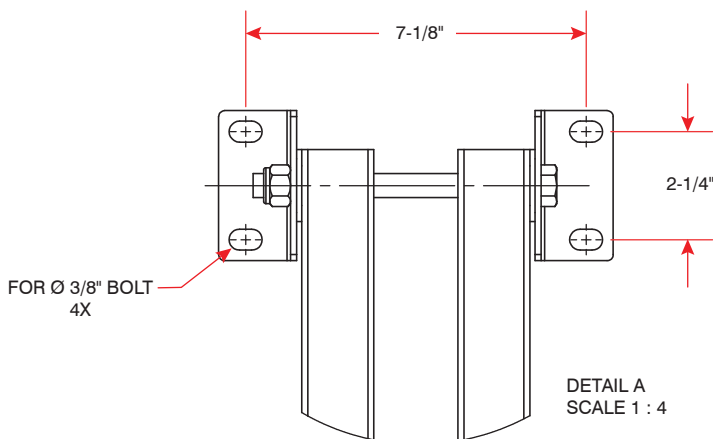

w.w.Cannon, Inc.

Design. Layout. Build. Install.

1-800-442-3061

www.wwcannon.com