



Hydraulic Edge of Dock Leveler

High performance hydraulic system. Ease of use, at the touch of a button.

The MD-CH Series hydraulic edge-of-dock leveler from Blue Giant is ideally suited for applications where installation of pit levelers is not feasible or where standard fleet bed heights are serviced at the loading dock.

The MD-CH Series is easily installed to the dock face providing an efficient self storing docking unit, with ease of use at the touch of a button.

Features

- Deck and lip operation provided by dual hydraulic maintenance free cylinders
- Smooth top plate transition
- Rugged remote mount single push button NEMA 4X (IP65) rated control
- Cylinders and motor pre-fitted to edge-of-dock assembly
- 1 HP motor
- Lifting hole in lip allows for quick and easy handling by installer

Structural Integrity

- Deck and lip plates made of premium grade 50,000 psi minimum yield four-way diamond tread plate
- Heavy-duty 3/8" x 6" back beam
- One-piece, continuous front and rear hinge pins for enhanced strength and durability
- Lip bevel helps protect forklift tires and steering systems and cargo

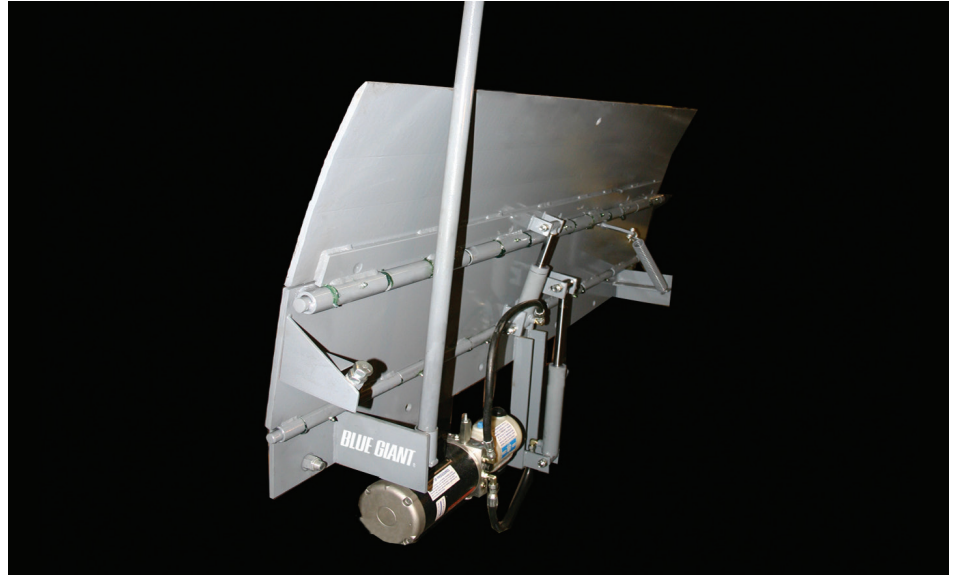

- Two (2) molded rubber bumpers bolted onto heavy-duty steel block extensions, to help protect building and dock from damage

Ease of service

- Single push button station
- Grease fittings to minimize operational friction
- Optional grip handle for use as maintenance stand (shown)

Operation

- Easy to deploy, less effort "operator maintains constant control"
- Working range capability of 5" (127 mm) above and 5" (127 mm) below dock level
- Self-storing upon truck departure

Associated products

- Vehicle restraint systems
- Light communication systems
- Wheel chocks



Stored traffic position



Front view

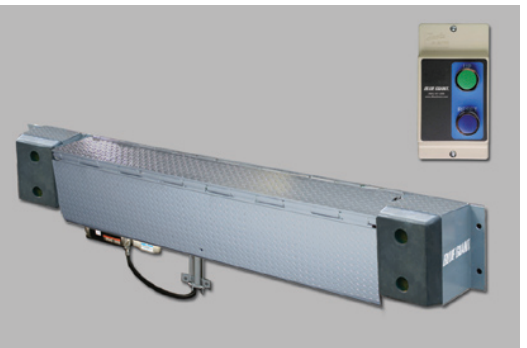

Isometric view

To meet OSHA and ANSI requirements and to minimize legal/insurance issues, the use of wheel chocks (at a minimum) is mandatory anytime equipment is used at the dock to load/unload vehicles. However, with the high lifetime cost of wheel chocks and their limited effectiveness, we recommend the combined use of vehicle restraints and wheel chocks as the accepted method of securing trucks to the dock. Blue Giant provides leading technology in manual and/or power activated vehicle restraints. Maximize your employee safety while providing your company a modern, safe loading dock area.

Standard construction features

- 15" (381 mm) lip with bevel edge
- Dual hydraulic cylinder (deck and lip)
- NEMA4X, 3-1/2" L x 7-1/4" H x 5-1/4" P (88 mm x 184 mm x 133 mm)
- 1 HP motor
- Welding procedure compliant with A.W.S.D.1.98 specifications
- Deck and lip constructed out of high tensile steel
- Four way diamond tread plate
- Hole in lip to help with easy handling and installation
- Two (2) molded rubber dock bumpers 10" W x 13" H x 4" D (254 mm x 330 mm x 102 mm) mounted to heavy-duty bumper blocks

Hydraulic operating system

Provides quiet, dependable and smooth cycling.

1. Maintain constant pressure on push button.
2. The deck raises to a vertical position and extends lip.

Lip operation

Lip automatically extends as unit is lowered onto truck bed.
Lip automatically returns to stored position upon truck departure.
The length of the lip shall not be less than 15" (381 mm).

Automatic vertical compensation and travel

Unit provides float up to 5" above and below dock level.

Automatic lateral compensation

Leveler shall have deck flex to compensate for canted (out of level) truck beds.

Rated capacity

- 30,000 lb (13,636 kg)

Optional Features

- 17" (432 mm) lip
- Flat lip
- Comfort grip handle for use as maintenance stand

Serviceability

- Grease fittings

Finish and color

- Unit to be painted gray

MODEL	CAPACITY	DECK SIZE (W x L)
<input type="checkbox"/> MDC7230H	30,000 lb (13,636 kg)	72" x 27" (1829 mm x 686 mm)
<input type="checkbox"/> MDC7830H		78" x 27" (1981 mm x 686 mm)

Warranty

Standard one-year parts and labor warranty from date of shipment. Warranties are subject to standard limitations on liability. Please consult Blue Giant warranties at www.bluegiant.com for full details on warranty information and product registration.

Installation Accessories

- Approach ramps
- Face plates
- 8" Pour-in channel

Optional Products

- Vehicle restraint systems
- Communication systems
- Wheel chock systems

Nominal Dimensions

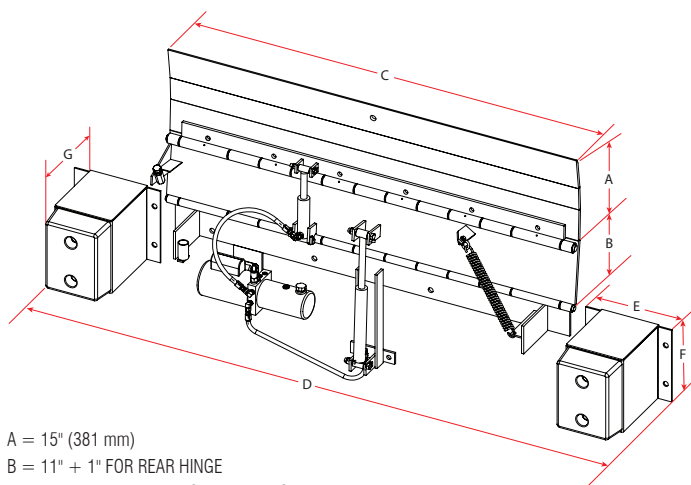

- A = 15" (381 mm)
- B = 11" + 1" FOR REAR HINGE
(279 mm + 25 mm FOR REAR HINGE)
- C = 72" / 78" (1829 / 1981 mm)
- D = DIMENSION C + 34" (864 mm)
- E = 15 1/2" (394 mm)
- F = 13" (330 mm)
- G = 16" (406 mm)

Note: Recommend minimum 8" structural concrete embedment (pour-in) channel, installed by others. Some components are not illustrated. Mounting anchors are not included.

Working range reduced by 2" when ordered with 17" lip and/or flat lip option.