

HIGH
SPEED
DOORS



CB 230



TECHNICAL DATA



AIR PERMEABILITY



HIGH SAFETIES



SELF-REPAIRING*



OIL FREE

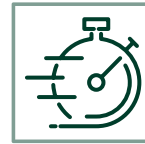

HIGH SPEED
Up to 2,5 m/s



GRAVITY TECHNOLOGY

MAXIMUM DIMENSIONS	W 4500 mm x H 4500 mm
SPEED	Max opening speed Up to 2,5 m/s
	Closing speed 0,8 m/s
CYCLES TEST	1.000.000
AIR PERMEABILITY	Class 2 / Class 5 with patented magnetic system
STRUCTURE	Not self-supporting
FRAME / MOTOR COVER HOOD	Standard Galvanized Steel
	Optional • Powder coated Steel • Stainless Steel 441/316
CURTAIN	Standard PVC curtain 900 gr/m ²
	Optional • Insulated • Translucent 35/40% • FDA (white) • Antistatic
SLIDING SYSTEM	Patented sliding system with high density Polyzene self-lubricant equipped of sliding zipper directly on curtain
CONTROL PANEL	Standard Powder coated steel box IP54 (300 x 500 x 150 mm)
	Optional • Stainless Steel • PVC box IP65 (300 x 400 x 150 mm)
	Inverter system 50/60 Hz with absolute encoder
	Power supply 1-ph, 230V max 16A
	Power supply 3-ph, 400V max 10A
	Power supply 3-ph, 230V max 16A
	Start/Stop Button
	2 free contacts (door open/ closed/ alert)
	Automatic/ Manual Interlocking between 2 doors
	IP rating for motor and control panel IP54
WIRING	Plug and Play system IP65
SAFETIES	Standard • Photocells set IP65 • Anti-jam sensor reverse • WiFi safety edge IP65
	Optional Multi ray light curtain barrier H2500 IP67
EMERGENCY OPENING	Standard Counterweight system Optional UPS battery
ADVISING OPERATIVE TEMPERATURE	Operating till - 10°C * with heating kit added - Not apt to be installed in negative/positive temperature

DynamicRoll® CB 230 is a self-repairing* roll up door designed to separate overpressured sterile environments, thanks to its sealing, the **CB 230** ensures controlled pressure leakage allowing the ventilation systems and air purification to operate correctly and is perfectly suited to controlled environments.

Equipped with counterweight the door can manage the opening even in case of power failure.

The specifically designed zip guide system allows the curtain to exit the guides in the event of impact and reinsert in one cycle. DynamicRoll® name assure the safety of staff, thanks to its curtain without rigid horizontal elements.



EN13241 CERTIFICATION

STANDARD	RIF.	TEST ACC.	RESULTS
WATER PERMEABILITY	EN 12425	EN 12489	Class 1
WIND LOAD	EN 12424	EN 12444	Class 2
AIR PERMEABILITY	EN 12426	EN 12427	Class 2
			Class 5 with patented magnetic system
SAFE OPENINGS	EN 12453	EN 12445	✓
MECHANICAL RESISTANCE	EN 12604	EN 12605	✓
UNINTENDED MOVEMENTS	EN 12604	EN 12605	✓
THERMAL TRANSMITTANCE	EN 12428	EN 12428	6,02 W/m ² K
PERFORMANCE (CYCLES)	EN 12604	EN 12605	1.000.000

Values can change depending on door dimensions

*System on demand due to possible change air permeability values

ADVANTAGES

- Self-repairing*
- Rapid
- Sealing
- Noiseless
- No rigid elements inside the curtain for 100% safety
- Plug & Play (easy to install)
- Low maintenance
- Energy savings
- Emergency opening with automatic counterweight

*System on demand cause it could change air permeability values

SLIDING SYSTEM / SELF-REPAIRING



APPLICATIONS



Pharmaceutical

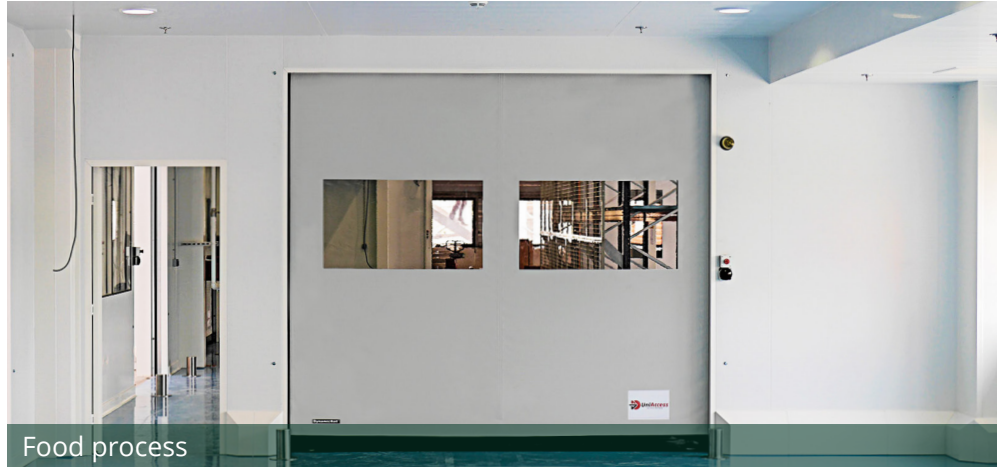

Food process



Pressure controlled environments



Clean rooms

DOOR SPACE REQUIREMENTS

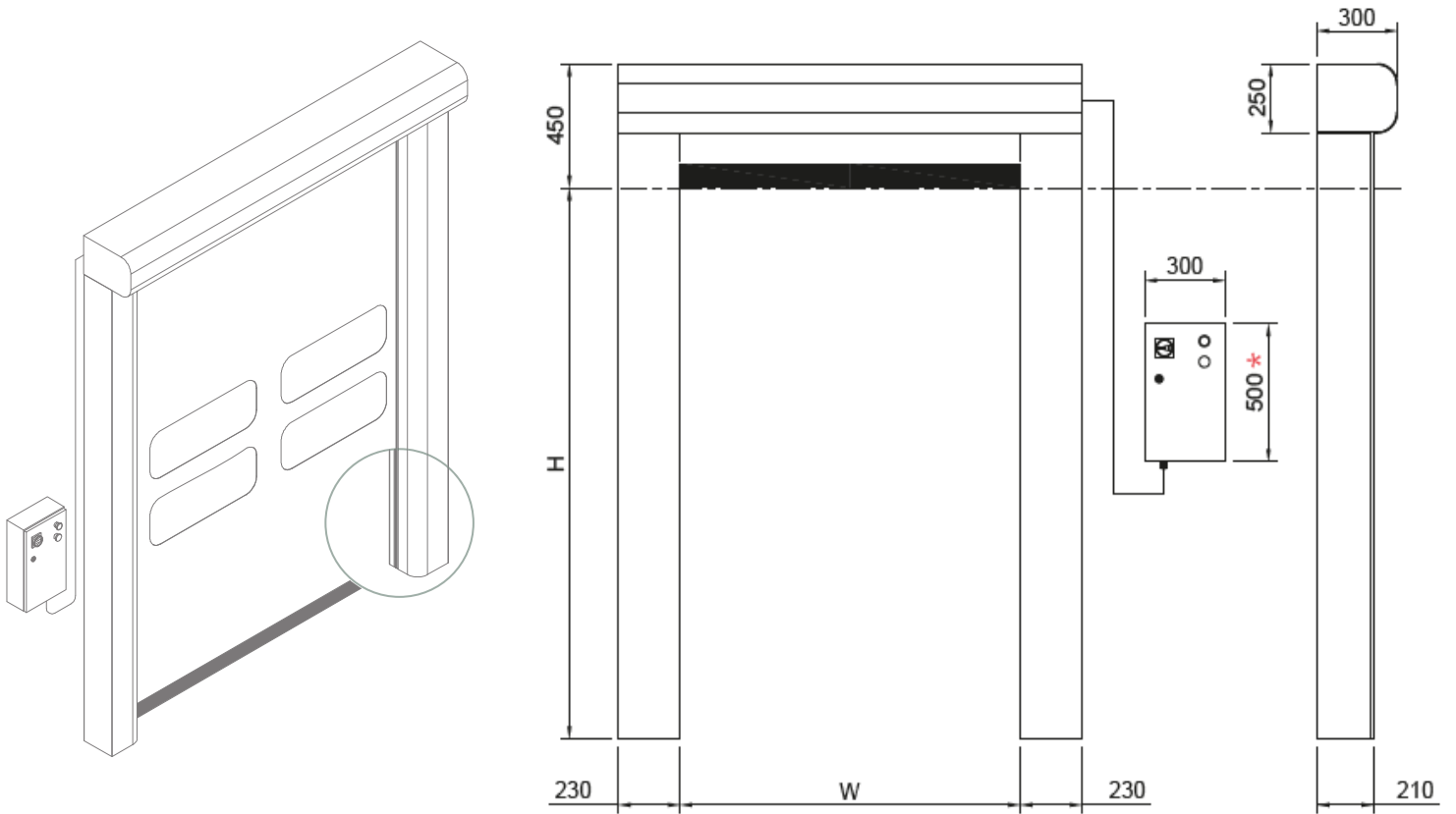

* If stainless steel 300 x 400 mm
If PVC 300 X 400 mm on all doors

FIXING DETAILS

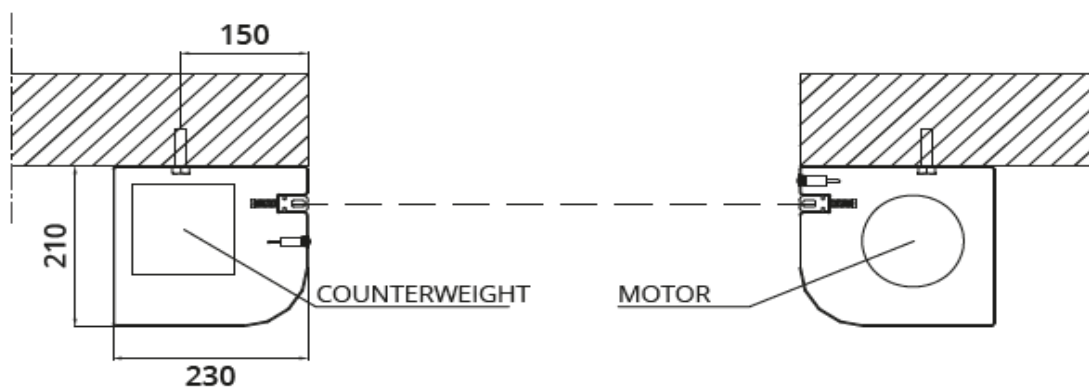

PVC CHARACTERISTICS

STANDARD PVC

Composition and tests

EXTERNAL SIDE			
Material	Finishing	Color	Thick
PVC	Opaque	18 standard	0,7 mm
FABRIC			
Material	N. tarps	Title	EN 2286-2
PES	1	1100Dtex 12x12	900 g/m ²
INTERNAL SIDE			
Material	Finishing	Color	Thick
PVC	Rough	18 standard	0,2 mm
COLD RESISTANCE			
ISO 4675/90 -50°C ±5			
HYDROLYSIS TEST			
75°C 95% humidity none variation			
GAS OIL TEST			
-			
none variation			
MARINE WATER TEST			
-			
none variation			
OZONE TEST			
ISO 3011 none crack			
T. STORAGE			
(°C) -30 +65			
FLAME TEST			
ISO 3795 < 100 mm/min			
PERFORATION			
RINA 3.A1.2.7 (N) > 100			
EXERCISE 7 days -70°C			
ISO 6065 none variation			

Characteristics

THICK	
ISO 2286/3	(mm) 0,9±0,1
WEIGHT	
ISO 2286/2	(kg/m ²) 0,90±0,1
LOAD BREAK	
ISO 1421	6000 N/50mm
WARP EXTENSION	
ISO 1421	4300 N/50mm
TEXTURE EXTENSION	
ISO 1421	4000 N/50mm
WARP BREAK	
dIN 53363	(N) > 600
TEXTURE BREAK	
dIN 53363	(N) > 530
ADHESION	
dIN EN ISO 2411	130 N/50mm
EEC CONFORMITY	
-	Yes
SPECIFIC USE	
industry, refrigerators, car washes, supermarkets, warehouses	
ASSOCIATION	
-	

Colors



Translucent Insulated available Antistatic available

FDA CERTIFICATED PVC

Food Drug Administration

TECHNICAL DATA

Composition and tests

TOP FACE COATING			
Material	Finish	Color	Thickness
PUR	Opaque	White	0,6 mm
FABRIC			
Material	N. tarps	Title	EN 2286-2
PET	1	2200 Dtex 12x12	1500 g/m ²
UNDERSIDE COATING			
Material	Finish	Color	Thickness
PUR	Plain	White	0,6 mm
COLD RESISTANCE			
ISO 4675/90 -30°C ±5			
TROPICAL TEST			
75°C 95% humidity none variation			
DIESEL FUEL TEST			
-			
none variation			
SEA WATER TEST			
-			
none variation			
OZONE TEST			
ISO 3011 none crack			
T. STORAGE			
(°C) -30 +65			
ABRASION			
ISO 5470/80, 5N C517 400 cycles (mg) 1			
PUNCTURE			
RINA 3.A1.2.7 (N) > 125			
EXERCISE 7 days -70°C			
ISO 6065 none variation			

Characteristics

THICKNESS	
ISO 2286/3	(mm) 1,20±0,1
WEIGHT	
ISO 2286/2	(kg/m ²) 1,30±0,1
TENSILE STRENGTH WARP	
ISO 1421	6000 N / 50mm
ELONGATION YARN	
ISO 1421	[%] > 14
ELONGATION WEFT	
ISO 1421	[%] > 20
TEAR RESISTANCE WARP	
dIN 53363	(N) > 250
TEAR RESISTANCE WEFT	
dIN 53363	(N) > 220
PEELING TEST	
dIN EN ISO 2411	130 N/50mm
FDA COMPLIANCE CEE	
Yes	
SPECIFIC USE	
cleanrooms, clinical, hospital	
ASSOCIATION	
DynamicRoll	

Disclaimer

The information contained in this document describes the features of the BMP EUROPE product as tested in a laboratory, other indications excepted, environment at a temperature of +23 degrees °C at 50% relative humidity. It does not necessarily reflect the conditions of industrial use and it does not guarantee the product to be suitable for certain applications. The client remains liable for the proper selection and correct use of the BMP EUROPE product. BMP EUROPE cannot be held responsible should damages arise from the use of its products. Necessary alterations to this data can be made without prior notice.

CRISTAL CHARACTERISTICS

PVC SUPERCLEAR

! SUITABLE ONLY FOR POSITIVE TEMPERATURE ENVIRONMENTS

WINDOWS - CRISTAL

TECHNICAL DATA

Article	SUPERCLEAR 0.75 mm FR
---------	-----------------------

Technical specifications	Standards	Unit	Values
Thickness	-	mm.	0.75
PVC total weight	-	g/m ²	940
Light transmission	JIS K - 7361	%	87.5
Tensile strength <i>Lengthwise MD</i>	JIS K - 6732	N	26.6
Tensile strength <i>Crosswise TD</i>	JIS K - 6732	N	24.2
Tear strength <i>Lengthwise MD</i>	JIS K - 6732	N	55.6
Tear strength <i>Crosswise TD</i>	JIS K - 6732	N	57.4
Elongation <i>Lengthwise MD</i>	JIS K - 6732	%	406
Elongation <i>Crosswise TD</i>	JIS K - 6732	%	414
Cold crack resistance	JIS K - 6772	°C	-40

OPTIONAL ACCESSORIES

RADAR



OPENING POINT
RADAR TOF/SPOT
for internal use only



INFRARED RADAR
with cross-movement
adjustment



INFRARED RADAR
motion and presence
(pedestrian/forklift) radar

TRAFFIC LIGHTS



GREEN FIXED STANDARD
traffic light



RED FIXED STANDARD
traffic light



LED TRAFFIC LIGHT
with countdown



LED TRAFFIC LIGHT
BARRIERS
(connection card included)

BUTTONS



OPENING GREEN
BUTTON
with box



OPENING BLACK
BUTTON
with box



FREEZE STOP
BUTTON
with box



NO TOUCH
BUTTON



TRAFFIC LIGHT
BUTTON
DUAL-FUNCTION
opening and
intermittent door
opening/closing
signaling



WIND GAUGE



KEY SELECTOR



REMOTE CONTROL



BOLLARD B-PROTECT



PULL CORD SWITCH



MAGNETIC LOOP DETECTOR

w.w.Cannon, Inc.
Design. Layout. Build. Install.
1-800-442-3061
www.wwcannon.com