

ARTICULATING JIB CRANES

125-550 lb. Capacity

Additional sizes available upon request

CraneWerks articulating jibs allow for easy placement of products where standard jibs or cranes will not allow. Its unique swivel arm allows for movement around corners and other obstructions.

Articulating jib cranes provide quick return on investment through increased productivity, reduced injuries, and improved safety.

Both base and wall mounted options are available.



Wall Mount

125 lb Capacity		200 lb Capacity		300 lb Capacity	
Model No.	Reach	Model No.	Reach	Model No.	Reach
CAW-125-6	6'	CAW-225-6	6'	CAW-550-6	6'
CAW-125-8	8'	CAW-225-8	8'	CAW-550-8	8'
CAW-125-10	10'	CAW-225-10	10'	CAW-550-10	10'
CAW-125-12	12'	CAW-225-12	12'	CAW-550-12	12'

Base Mount

125 lb Capacity			
Model No.	Reach	Height Under Boom	Overall Height
CAB-125-6-10	6'	8'- 8"	10'
CAB-125-8-10	8'	8'- 3"	10'
CAB-125-10-10	10'	7'- 7"	10'
CAB-125-12-10	12'	7'- 3"	10'

550 lb Capacity			
Model No.	Reach	Height Under Boom	Overall Height
CAB-550-6-10	6'	8'- 3"	10'
CAB-550-8-10	8'	7'- 7"	10'
CAB-550-10-10	10'	7'- 3"	10'
CAB-550-12-10	12'	6'- 9"	10'

225 lb Capacity			
Model No.	Reach	Height Under Boom	Overall Height
CAB-225-6-10	6'	8'- 8"	10'
CAB-225-8-10	8'	8'- 3"	10'
CAB-225-10-10	10'	7'- 7"	10'
CAB-225-12-10	12'	7'- 3"	10'

Standard Features

- Compatible with air, vacuum, and electric lifts; hoists; and balancers
- Precision ball bearing construction for ease of movement
- Meets or exceeds all OSHA, ANSI, CMAA, HMI, & NEC requirements
- CAD approval drawings for ease of layout
- Safety yellow paint

Available Options

- Rotation stops (main or secondary arm)
- Adjustable rotation brake
- 360° rotation available on select models
- Portable base
- Anchor bolts
- Base plate templates
- Custom paint

Additional lengths, heights, and capacities available.



Wall Mount

125 lb Capacity		
Model No.	A	E
CAW-125-6-10	6'	18"
CAW-125-8-10	8'	18"
CAW-125-10-10	10'	24"
CAW-125-12-10	12'	26"

225 lb Capacity		
Model No.	A	E
CAW-225-6-10	6'	18"
CAW-225-8-10	8'	18"
CAW-225-10-10	10'	24"
CAW-225-12-10	12'	26"

550 lb Capacity		
Model No.	A	E
CAW-550-6-10	6'	24"
CAW-550-8-10	8'	24"
CAW-550-10-10	10'	26"
CAW-550-12-10	12'	30"

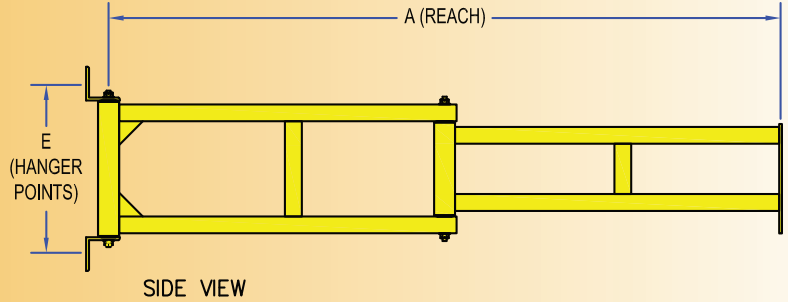
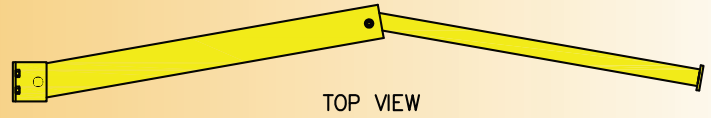

Base Mount

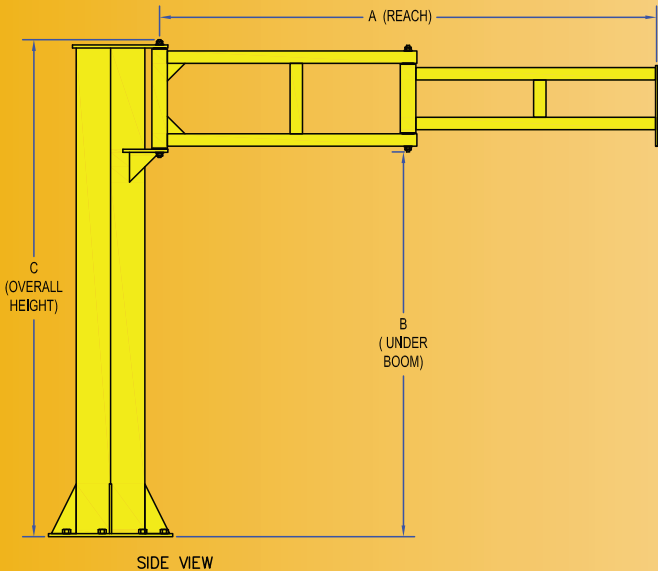
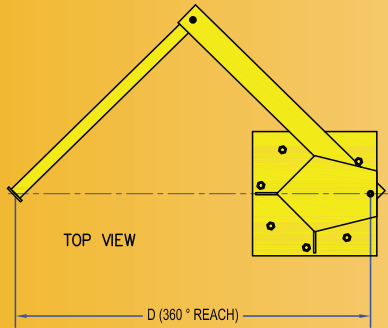

125 lb Capacity				
Model No.	A	B	C	D
CAB-125-6-10	6'	8'- 8"	10'	3'- 8"
CAB-125-8-10	8'	8'- 3"	10'	5'- 2"
CAB-125-10-10	10'	7'- 8"	10'	6'- 10"
CAB-125-12-10	12'	7'- 3"	10'	8'- 3"

225 lb Capacity				
Model No.	A	B	C	D
CAB-225-6-10	6'	8'- 8"	10'	3'- 8"
CAB-225-8-10	8'	8'- 3"	10'	5'- 2"
CAB-225-10-10	10'	7'- 7"	10'	6'- 10"
CAB-225-12-10	12'	7'- 3"	10'	8'- 3"

550 lb Capacity				
Model No.	A	B	C	D
CAB-550-6-10	6'	8'- 3"	10'	3'- 8"
CAB-550-8-10	8'	7'- 7"	10'	5'- 2"
CAB-550-10-10	10'	7'- 3"	10'	6'- 10"
CAB-550-12-10	12'	6'- 9"	10'	8'- 3"

