

HIGH
SPEED
DOORS



FOOD INOX



TECHNICAL DATA



HIGH SPEED
2,5 m/s



HIGH SAFETIES



SELF-REPAIRING



OIL FREE



WATER DRAIN



WASHABLE



GRAVITY TECHNOLOGY

MAXIMUM DIMENSIONS	W 6500 mm x H 6500 mm
SPEED	2,5 m/s
CYCLES TEST	1.000.000
WIND RESISTANCE	3000 x 3000 Class 3 5000 x 5000 Class 2
STRUCTURE	Not self-supporting
FRAME / MOTOR COVER HOOD	Standard Stainless Steel 441
	Optional Stainless Steel 304/316
CURTAIN	Standard PVC curtain 900 gr/m ²
	Optional • Translucent 35/40% • FDA (white) • Antistatic
SLIDING SYSTEM	Patented sliding system with high density Polyzene self-lubricant equipped of sliding zipper directly on curtain
CONTROL PANEL	Standard PVC box (300 x 400 x 150 mm)
	Optional • Stainless Steel • Powder coated steel box IP54 (300 x 500 x 150 mm)
	Inverter system 50/60 Hz with absolute encoder
	Power supply 1-ph, 230V max 16A
	Power supply 3-ph, 400V max 10A
	Power supply 3-ph, 230V max 16A
	Start/Stop Button
	2 free contacts (door open/ closed/ alert)
	Automatic/ Manual Interlocking between 2 doors
	IP rating for motor and control panel IP54
WIRING	Plug and Play system IP65
SAFETIES	Standard • Photocells set IP65 • Anti-jam sensor reverse
	Optional • WiFi safety edge IP65 • Multi ray light curtain barrier H 2500 IP67
EMERGENCY OPENING	Standard Hand crank
	Optional Chain system UPS battery
ADVISING OPERATIVE TEMPERATURE	Operating till -30 C° with heating kit added - Not apt to be installed in negative/positive temperature

DynamicRoll® FOOD INOX is a self-repairing roll up door, with specific features to satisfy all Food process requirements.

Designed with special attention to hygiene. This door has Food certifications in several countries. Characterized by the Stainless Steel frame and designed to prevent the build up of collecting of liquid, dust or any impurity on the frame, this door is washable in all parts respecting the hygienic restrictions of the field. Its speed will let the door maintain the different characteristics of the environment they are located in.

EN13241 CERTIFICATION

STANDARD	RIF.	TEST ACC.	RESULTS
WATER PERMEABILITY	EN 12425	EN 12489	Class 1
WIND LOAD	EN 12424	EN 12444	Maximum Class 4
AIR PERMEABILITY	EN 12426	EN 12427	Class 1
SAFE OPENINGS	EN 12453	EN 12445	✓
MECHANICAL RESISTANCE	EN 12604	EN 12605	✓
UNINTENDED MOVEMENTS	EN 12604	EN 12605	✓
THERMAL TRANSMITTANCE	EN 12428	EN 12428	6,02 W/m ² K
PERFORMANCE (CYCLES)	EN 12604	EN 12605	1.000.000

Values can change depending on door dimensions

ADVANTAGES

- Self-repairing
- Rapid
- Sealing
- Noiseless
- No rigid elements inside the curtain for 100% safety
- Plug & Play (easy to install)
- Low maintenance
- Energy savings
- Washable
- Hygienic

SLIDING SYSTEM / SELF-REPAIRING

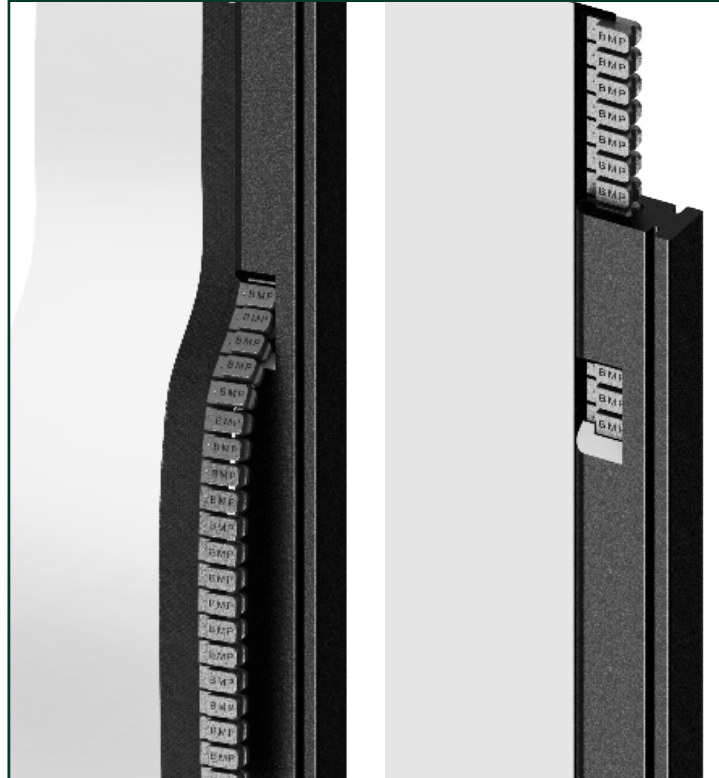

APPLICATIONS



Food and agriculture industry



Large retailers



Chemical



Pharmaceutical



General industry

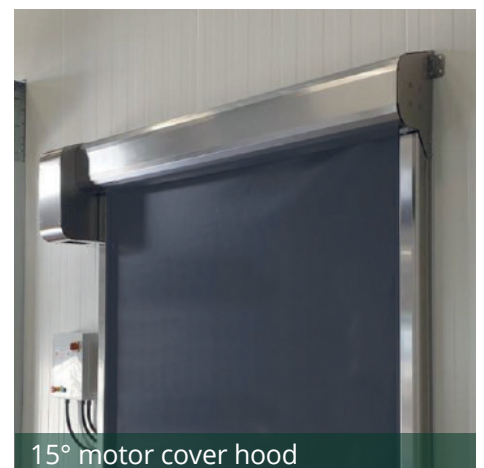

15° motor cover hood

DOOR SPACE REQUIREMENTS

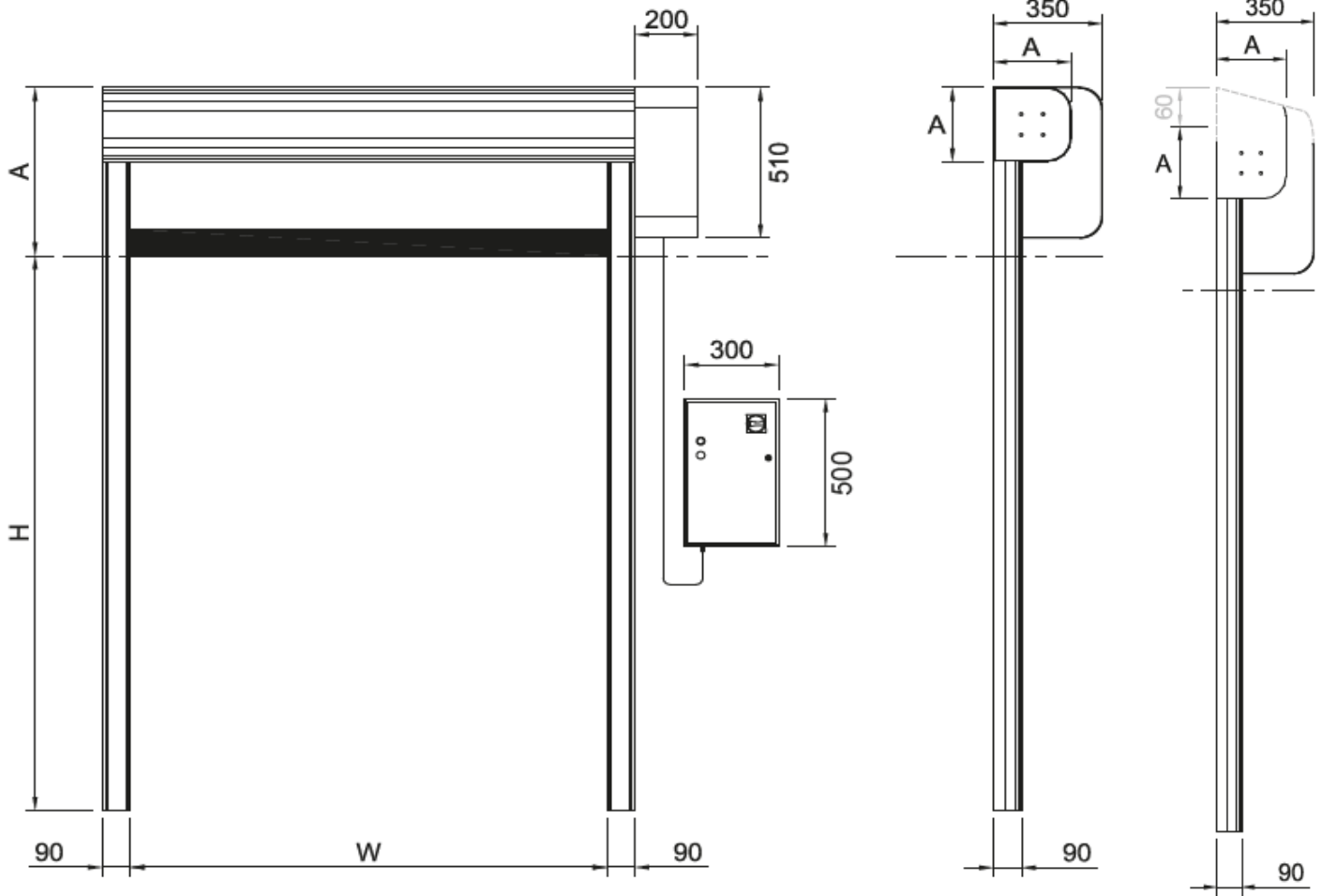

< H 3000 A = 250
> H 3000 A = 350

15° motor cover hood

FIXING DETAILS

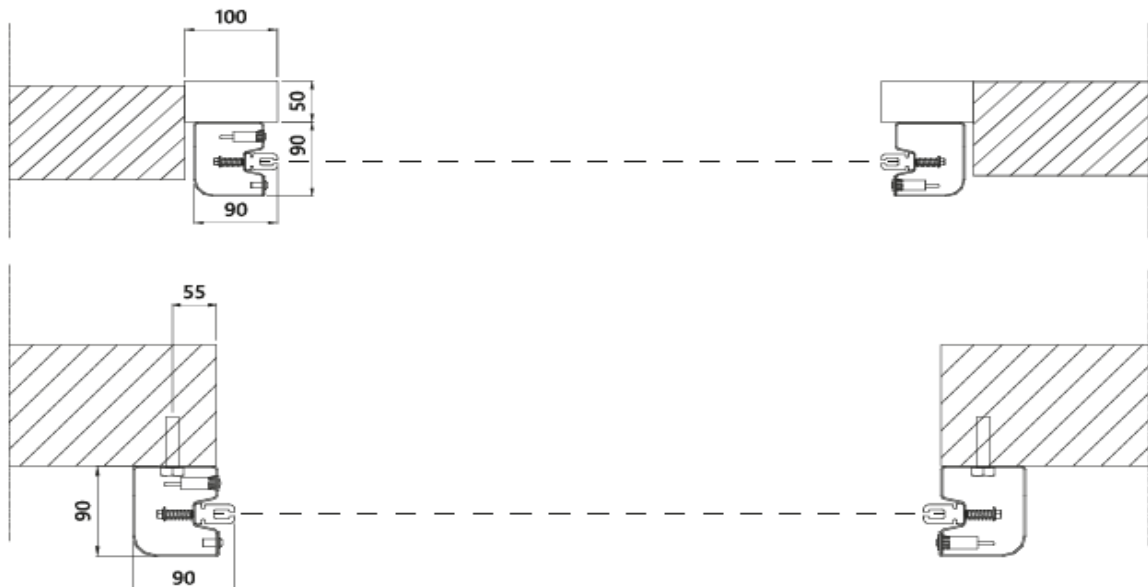

PVC CHARACTERISTICS

STANDARD PVC

Composition and tests

EXTERNAL SIDE			
Material	Finishing	Color	Thick
PVC	Opaque	18 standard	0,7 mm
FABRIC			
Material	N. tarps	Title	EN 2286-2
PES	1	1100Dtex 12x12	900 g/m ²
INTERNAL SIDE			
Material	Finishing	Color	Thick
PVC	Rough	18 standard	0,2 mm
COLD RESISTANCE ISO 4675/90 -50°C ±5			
HYDROLYSIS TEST 75°C 95% humidity none variation			
GAS OIL TEST - none variation			
MARINE WATER TEST - none variation			
OZONE TEST ISO 3011 none crack			
T. STORAGE (°C) -30 +65			
FLAME TEST ISO 3795 < 100 mm/min			
PERFORATION RINA 3.A1.2.7 (N) > 100			
EXERCISE 7 days -70°C ISO 6065 none variation			

Characteristics

THICK ISO 2286/3 (mm) 0,9±0,1
WEIGHT ISO 2286/2 (kg/m ²) 0,90±0,1
LOAD BREAK ISO 1421 6000 N/50mm
WARP EXTENSION ISO 1421 4300 N/50mm
TEXTURE EXTENSION ISO 1421 4000 N/50mm
WARP BREAK dIN 53363 (N) > 600
TEXTURE BREAK dIN 53363 (N) > 530
ADHESION dIN EN ISO 2411 130 N/50mm
EEC CONFORMITY - Yes
SPECIFIC USE industry, refrigerators, car washes, supermarkets, warehouses
ASSOCIATION -

Colors



 Translucent  Antistatic available

INSULATED PVC

Composition and tests

EXTERNAL SIDE			
Material	Finishing	Color	Thick
PVC	Straight	6 standard	0,5 mm
FABRIC			
Material	N. tarps	Title	EN 2286-2
PES	1	1100Dtex 12x12	1350 g/m ²
INTERNAL SIDE			
Material	Finishing	Color	Thick
PVC	Sponge	6 standard	7 mm
COLD RESISTANCE ISO 4675/90 -10°C ±5			
HYDROLYSIS TEST 75°C 95% humidity none variation			
GAS OIL TEST - none variation			
MARINE WATER TEST - none variation			
OZONE TEST ISO 3011 none crack			
T. STORAGE (°C) -30 +65			
FLAME TEST ISO 3795 cl 2, NFPA 701 test 2			
PERFORATION RINA 3.A1.2.7 (N) > 100			
EXERCISE 7 days -70°C ISO 6065 none variation			

Characteristics

THICK ISO 2286/3 (mm) 7,0±0,1
WEIGHT ISO 2286/2 (kg/m ²) 1,7±0,1
LOAD BREAK ISO 1421 6000 N/50mm
WARP EXTENSION ISO 1421/V1 3000 N/50mm
TEXTURE EXTENSION ISO 1421/V1 2800 N/50mm
WARP BREAK dIN 53363 300 N
TEXTURE BREAK dIN 53363 300 N
ADHESION PA 09.03 (internal) 15 N/cm
THERMAL CONDUCTIVITY - 0,03782 W.m ⁻¹
ISOLATION INDEX - Rw= 17,5 dB
EMPLOYMENT industry, refrigerators, car washes, supermarkets, warehouses
ASSOCIATION -

Colors

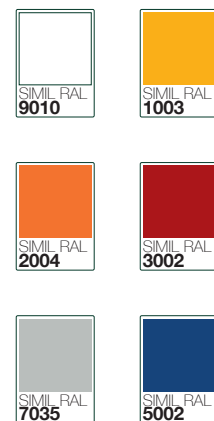

CRISTAL CHARACTERISTICS

PVC SUPERCLEAR

! SUITABLE ONLY FOR POSITIVE TEMPERATURE ENVIRONMENTS

WINDOWS - CRISTAL TECHNICAL DATA

Article	SUPERCLEAR 0.75 mm FR
---------	-----------------------

Technical specifications	Standards	Unit	Values
Thickness	-	mm.	0.75
PVC total weight	-	g/m ²	940
Light transmission	JIS K - 7361	%	87.5
Tensile strength <i>Lengthwise MD</i>	JIS K - 6732	N	26.6
Tensile strength <i>Crosswise TD</i>	JIS K - 6732	N	24.2
Tear strength <i>Lengthwise MD</i>	JIS K - 6732	N	55.6
Tear strength <i>Crosswise TD</i>	JIS K - 6732	N	57.4
Elongation <i>Lengthwise MD</i>	JIS K - 6732	%	406
Elongation <i>Crosswise TD</i>	JIS K - 6732	%	414
Cold crack resistance	JIS K - 6772	°C	-40
Flame retardancy	-	-	No
Hardness	-	-	4.0S
Standard length	-	m	30
Standard width	-	m	1.37

FDA CERTIFICATED PVC

Food Drug Administration

TECHNICAL DATA

Composition and tests

TOP FACE COATING			
Material	Finish	Color	Thickness
PUR	Opaque	White	0,6 mm
FABRIC			
Material	N. tarps	Title	EN 2286-2
PET	1	2200 Dtex 12x12	1500 g/m ²
UNDERSIDE COATING			
Material	Finish	Color	Thickness
PUR	Plain	White	0,6 mm
COLD RESISTANCE			
ISO 4675/90 -30°C ±5			
TROPICAL TEST			
75°C 95% humidity none variation			
DIESEL FUEL TEST			
- none variation			
SEA WATER TEST			
- none variation			
OZONE TEST			
ISO 3011 none crack			
T. STORAGE			
(°C) -30 +65			
ABRASION			
ISO 5470/80, 5N C517 400 cycles (mg) 1			
PUNCTURE			
RINA 3.A1.2.7 (N) > 125			
EXERCISE 7 days -70°C			
ISO 6065 none variation			

Characteristics

THICKNESS	
ISO 2286/3 (mm) 1,20±0,1	
WEIGHT	
ISO 2286/2 (kg/m ²) 1,30±0,1	
TENSILE STRENGTH WARP	
ISO 1421 6000 N / 50mm	
ELONGATION YARN	
ISO 1421 [%] > 14	
ELONGATION WEFT	
ISO 1421 [%] > 20	
TEAR RESISTANCE WARP	
dIN 53363 (N) > 250	
TEAR RESISTANCE WEFT	
dIN 53363 (N) > 220	
PEELING TEST	
dIN ISO 2411 130 N/50mm	
FDA COMPLIANCE CEE	
Yes	
SPECIFIC USE	
cleanrooms, clinical, hospital	
ASSOCIATION	
DynamicRoll	

Disclaimer

The information contained in this document describes the features of the BMP EUROPE product as tested in a laboratory, other indications excepted, environment at a temperature of +23 degrees °C at 50% relative humidity. It does not necessarily reflect the conditions of industrial use and it does not guarantee the product to be suitable for certain applications. The client remains liable for the proper selection and correct use of the BMP EUROPE product. BMP EUROPE cannot be held responsible should damages arise from the use of its products. Necessary alterations to this data can be made without prior notice.

OPTIONAL ACCESSORIES



RADAR



OPENING POINTING RADAR
TOF/SPOT
for internal use only



INFRARED RADAR
with cross-movement
adjustment



INFRARED RADAR
motion and presence
(pedestrian/forklift) radar

TRAFFIC LIGHTS



GREEN FIXED STANDARD
traffic light



RED FIXED STANDARD
traffic light



LED TRAFFIC LIGHT
with countdown

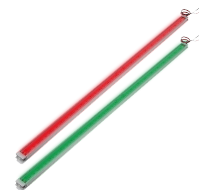

LED TRAFFIC LIGHT BARRIERS
(connection card included)

BUTTONS



OPENING GREEN BUTTON
with box



OPENING BLACK BUTTON
with box



FREEZE STOP BUTTON
with box



NO TOUCH BUTTON



TRAFFIC LIGHT BUTTON
DUAL-FUNCTION
opening and
intermittent door
opening/closing
signaling



WIND GAUGE



KEY SELECTOR



REMOTE CONTROL



BOLLARD B-PROTECT



PULL CORD SWITCH



MAGNETIC LOOP DETECTOR

w.w.Cannon, Inc.

Design. Layout. Build. Install.

1-800-442-3061
www.wwcannon.com