



HIGH  
SPEED  
DOORS



DynamicRoll

FOOD PE



# TECHNICAL DATA



**HIGH SPEED**  
Up to 2 m/s



**HIGH SAFETIES**



**SELF-REPAIRING**



**OIL FREE**



**POLYETHYLENE CURTAIN**  
**ALIMENTARY**



**WASHABLE**



**GRAVITY**  
**TECHNOLOGY**

<b>MAXIMUM DIMENSIONS</b>	W 4500 mm x H 3800 mm
<b>SPEED</b>	<b>Max opening speed</b> Up to 2 m/s
	<b>Closing speed</b> 0,6 m/s
<b>CYCLES TEST</b>	1.000.000
<b>WIND RESISTANCE</b>	Class 0
<b>STRUCTURE</b>	Not self-supporting
<b>FRAME</b>	<b>Standard</b> Polyethylene HD 1.000.000
<b>MOTOR COVER</b>	Stainless Steel
<b>CURTAIN</b>	<b>Standard</b> PVC curtain 1300 gr/m <sup>2</sup> , 6 W/m <sup>2</sup> K
	<b>Optional</b> <ul style="list-style-type: none"> <li>• Translucent 35/40%</li> <li>• FDA (white)</li> <li>• Antistatic</li> </ul>
<b>SLIDING SYSTEM</b>	Patented sliding system with high density Polyzene self-lubricant equipped of sliding zipper directly on curtain
	<b>Standard</b> PVC box IP65 (300 x 400 x 150 mm)
<b>CONTROL PANEL</b>	<b>Optional</b> <ul style="list-style-type: none"> <li>• Stainless Steel</li> <li>• Powder coated steel box IP54 (300 x 500 x 150 mm)</li> </ul>
	Inverter system 50/60 Hz with absolute encoder
	Power supply 1-ph, 230V max 16A
	Power supply 3-ph, 400V max 10A
	Power supply 3-ph, 230V max 16A
	Start/ Stop button
	2 free contacts (door open/closed/alert)
	Automatic/ Manual Interlocking between 2 doors
	IP rating for motor and control panel IP54
	<b>WIRING</b>
<b>SAFETIES</b>	<b>Standard</b> <ul style="list-style-type: none"> <li>• Photocells set IP65</li> <li>• Anti-jam sensor reverse</li> </ul>
	<b>Optional</b> <ul style="list-style-type: none"> <li>• WiFi safety edge IP65</li> </ul>
<b>EMERGENCY OPENING</b>	<b>Standard</b> Hand crank
	<b>Optional</b> <ul style="list-style-type: none"> <li>• Chain system</li> <li>• UPS battery</li> </ul>
<b>ADVISING OPERATIVE TEMPERATURE</b>	Operating till positive temperature (> 0°C) Not apt to be installed in negative/positive temperature

**DynamicRoll® FOOD PE** is a self-repairing roll up door studied to environments, where hygiene is the most important issue. Its Polyethylene frame is designed to be sanitized in all its parts, without removal or disassembly of any profiles or covers with related problems in assembling again all screws and external elements.

Columns come out from a Polyethylene monolithic section, where the zippers on the curtain run inside.

The specifically designed zip guide system allows the curtain to exit the guides in the event of impact and reinsert in one cycle.

## EN13241 CERTIFICATION

STANDARD	RIF.	TEST ACC.	RESULTS
<b>WATER PERMEABILITY</b>	EN 12425	EN 12489	Class 1
<b>WIND LOAD</b>	EN 12424	EN 12444	Class 0
<b>AIR PERMEABILITY</b>	EN 12426	EN 12427	Class 0
<b>SAFE OPENINGS</b>	EN 12453	EN 12445	✓
<b>MECHANICAL RESISTANCE</b>	EN 12604	EN 12605	✓
<b>UNINTENDED MOVEMENTS</b>	EN 12604	EN 12605	✓
<b>THERMAL TRANSMITTANCE</b>	EN 12428	EN 12428	6,02 W/m <sup>2</sup> K
<b>PERFORMANCE (CYCLES)</b>	EN 12604	EN 12605	1.000.000

Values can change depending on door dimensions



# ADVANTAGES

- Rapid
- Sealing
- Noiseless
- No rigid elements inside the curtain for 100% safety
- Plug & play (easy to install)
- Low maintenance
- Energy savings
- Sanitized in all parts
- Easily washable
- Hygienic

## SLIDING SYSTEM / SELF-REPAIRING

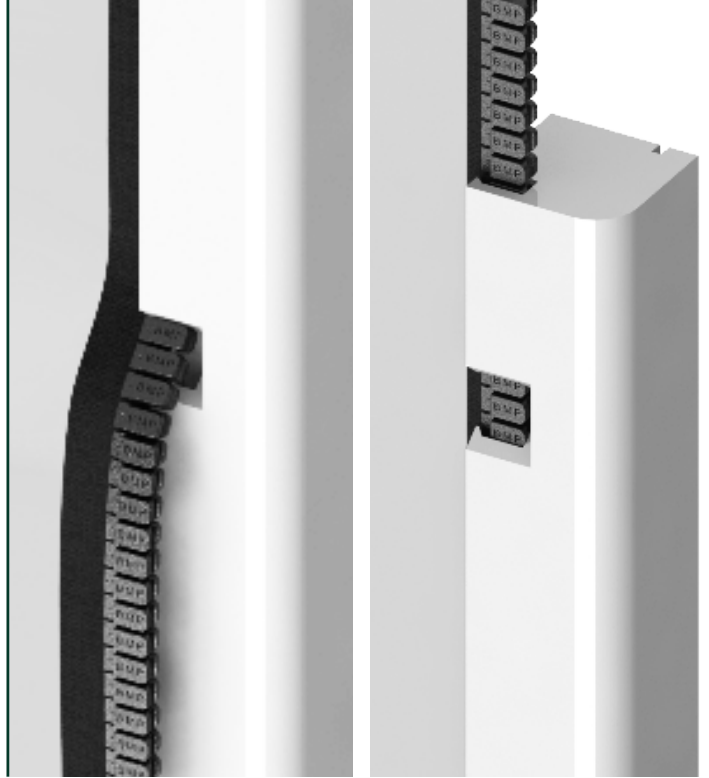

# APPLICATION



Agriculture / Food industry

# DOOR SPACE REQUIREMENTS

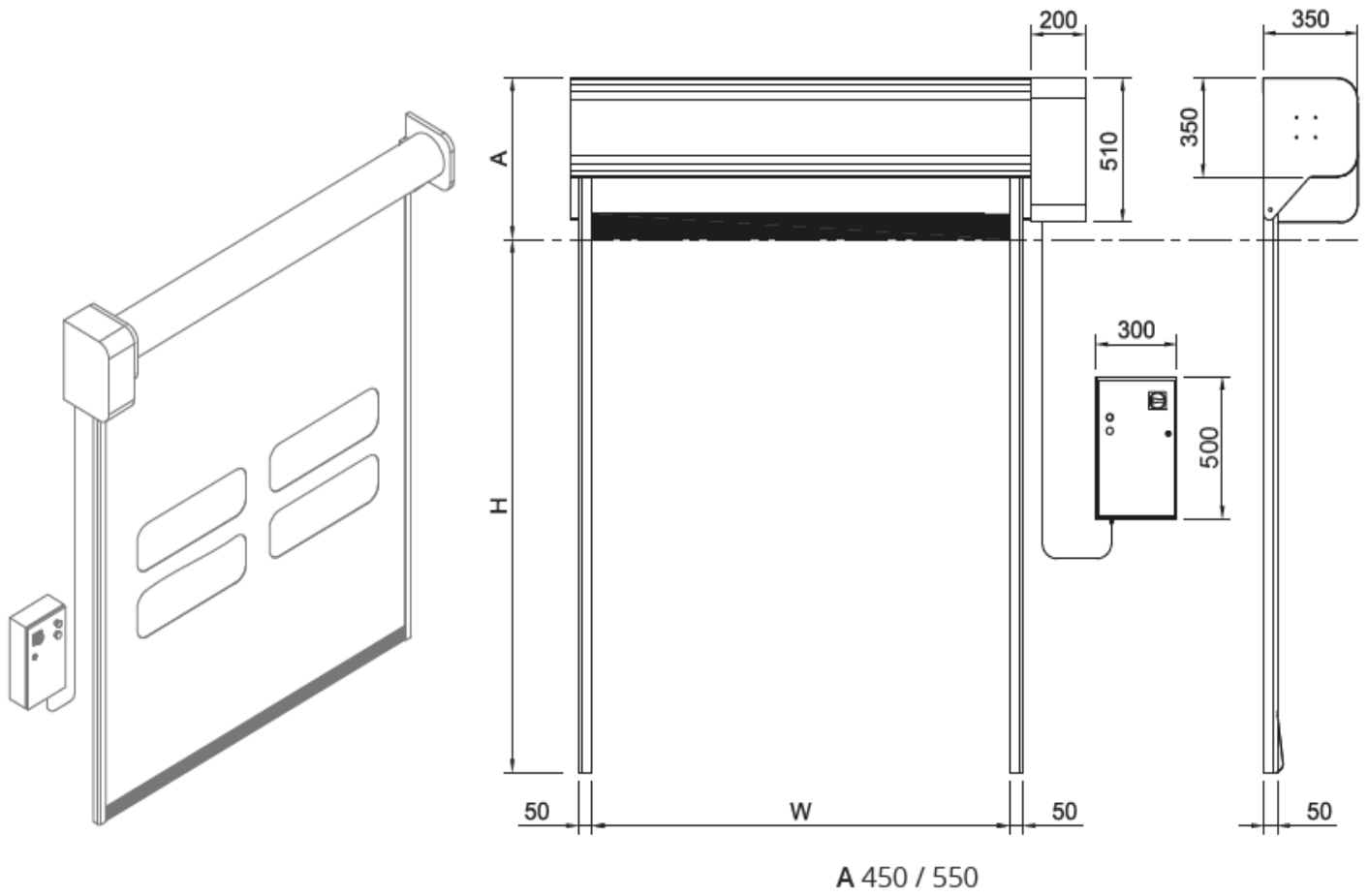

## FIXING DETAILS



# PVC CHARACTERISTICS

## STANDARD PVC

### Composition and tests

EXTERNAL SIDE			
Material	Finishing	Color	Thick
PVC	Opaque	18 standard	0,7 mm
FABRIC			
Material	N. tarps	Title	EN 2286-2
PES	1	1100Dtex 12x12	900 g/m <sup>2</sup>
INTERNAL SIDE			
Material	Finishing	Color	Thick
PVC	Rough	18 standard	0,2 mm
<b>COLD RESISTANCE</b> ISO 4675/90 -50°C ±5			
<b>HYDROLYSIS TEST</b> 75°C 95% humidity none variation			
<b>GAS OIL TEST</b> -			
none variation			
<b>MARINE WATER TEST</b> -			
none variation			
<b>OZONE TEST</b> ISO 3011 none crack			
<b>T. STORAGE</b> (°C) -30 +65			
<b>FLAME TEST</b> ISO 3795 < 100 mm/min			
<b>PERFORATION</b> RINA 3.A1.2.7 (N) > 100			
<b>EXERCISE 7 days -70°C</b> ISO 6065 none variation			

### Characteristics

<b>THICK</b> ISO 2286/3 (mm) 0,9±0,1
<b>WEIGHT</b> ISO 2286/2 (kg/m <sup>2</sup> ) 0,90±0,1
<b>LOAD BREAK</b> ISO 1421 6000 N/50mm
<b>WARP EXTENSION</b> ISO 1421 4300 N/50mm
<b>TEXTURE EXTENSION</b> ISO 1421 4000 N/50mm
<b>WARP BREAK</b> dIN 53363 (N) > 600
<b>TEXTURE BREAK</b> dIN 53363 (N) > 530
<b>ADHESION</b> dIN EN ISO 2411 130 N/50mm
<b>EEC CONFORMITY</b> -
Yes
<b>SPECIFIC USE</b> industry, refrigerators, car washes, supermarkets, warehouses
<b>ASSOCIATION</b> -

### Colors



 Translucent  Antistatic available

## INSULATED PVC

### Composition and tests

EXTERNAL SIDE			
Material	Finishing	Color	Thick
PVC	Straight	6 standard	0,5 mm
FABRIC			
Material	N. tarps	Title	EN 2286-2
PES	1	1100Dtex 12x12	1350 g/m <sup>2</sup>
INTERNAL SIDE			
Material	Finishing	Color	Thick
PVC	Sponge	6 standard	7 mm
<b>COLD RESISTANCE</b> ISO 4675/90 -10°C ±5			
<b>HYDROLYSIS TEST</b> 75°C 95% humidity none variation			
<b>GAS OIL TEST</b> -			
none variation			
<b>MARINE WATER TEST</b> -			
none variation			
<b>OZONE TEST</b> ISO 3011 none crack			
<b>T. STORAGE</b> (°C) -30 +65			
<b>FLAME TEST</b> ISO 3795 cl 2, NFPA 701 test 2			
<b>PERFORATION</b> RINA 3.A1.2.7 (N) > 100			
<b>EXERCISE 7 days -70°C</b> ISO 6065 none variation			

### Characteristics

<b>THICK</b> ISO 2286/3 (mm) 7,0±0,1
<b>WEIGHT</b> ISO 2286/2 (kg/m <sup>2</sup> ) 1,7±0,1
<b>LOAD BREAK</b> ISO 1421 6000 N/50mm
<b>WARP EXTENSION</b> ISO 1421/V1 3000 N/50mm
<b>TEXTURE EXTENSION</b> ISO 1421/V1 2800 N/50mm
<b>WARP BREAK</b> dIN 53363 300 N
<b>TEXTURE BREAK</b> dIN 53363 300 N
<b>ADHESION</b> PA 09.03 (internal) 15 N/cm
<b>THERMAL CONDUCTIVITY</b> -
0,03782 W.m <sup>-1</sup>
<b>ISOLATION INDEX</b> -
Rw= 17,5 dB
<b>EMPLOYMENT</b> industry, refrigerators, car washes, supermarkets, warehouses
<b>ASSOCIATION</b> -

### Colors

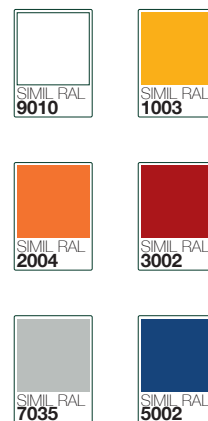

# CRISTAL CHARACTERISTICS

## PVC SUPERCLEAR

**! SUITABLE ONLY FOR POSITIVE TEMPERATURE ENVIRONMENTS**

### WINDOWS - CRISTAL TECHNICAL DATA

Article	SUPERCLEAR 0.75 mm FR
---------	-----------------------

Technical specifications	Standards	Unit	Values
Thickness	-	mm.	0.75
PVC total weight	-	g/m <sup>2</sup>	940
Light transmission	JIS K - 7361	%	87.5
Tensile strength <i>Lengthwise MD</i>	JIS K - 6732	N	26.6
Tensile strength <i>Crosswise TD</i>	JIS K - 6732	N	24.2
Tear strength <i>Lengthwise MD</i>	JIS K - 6732	N	55.6
Tear strength <i>Crosswise TD</i>	JIS K - 6732	N	57.4
Elongation <i>Lengthwise MD</i>	JIS K - 6732	%	406
Elongation <i>Crosswise TD</i>	JIS K - 6732	%	414
Cold crack resistance	JIS K - 6772	°C	-40
Flame retardancy	-	-	No
Hardness	-	-	4.0S
Standard length	-	m	30
Standard width	-	m	1.37

## FDA CERTIFICATED PVC

Food Drug Administration

### TECHNICAL DATA

#### Composition and tests

TOP FACE COATING			
<i>Material</i>	<i>Finish</i>	<i>Color</i>	<i>Thickness</i>
PUR	Opaque	White	0,6 mm
FABRIC			
<i>Material</i>	<i>N. tarps</i>	<i>Title</i>	<i>EN 2286-2</i>
PET	1	2200 Dtex 12x12	1500 g/m <sup>2</sup>
UNDERSIDE COATING			
<i>Material</i>	<i>Finish</i>	<i>Color</i>	<i>Thickness</i>
PUR	Plain	White	0,6 mm
<b>COLD RESISTANCE</b> ISO 4675/90 -30°C ±5			
<b>TROPICAL TEST</b> 75°C 95% humidity none variation			
<b>DIESEL FUEL TEST</b> - none variation			
<b>SEA WATER TEST</b> - none variation			
<b>OZONE TEST</b> ISO 3011 none crack			
<b>T. STORAGE</b> (°C) -30 +65			
<b>ABRASION</b> ISO 5470/80, 5N C517 400 cycles (mg) 1			
<b>PUNCTURE</b> RINA 3.A1.2.7 (N) > 125			
<b>EXERCISE 7 days -70°C</b> ISO 6065 none variation			

#### Characteristics

<b>THICKNESS</b> ISO 2286/3 (mm) 1,20±0,1
<b>WEIGHT</b> ISO 2286/2 (kg/m <sup>2</sup> ) 1,30±0,1
<b>TENSILE STRENGTH WARP</b> ISO 1421 6000 N / 50mm
<b>ELONGATION YARN</b> ISO 1421 [%] > 14
<b>ELONGATION WEFT</b> ISO 1421 [%] > 20
<b>TEAR RESISTANCE WARP</b> dIN 53363 (N) > 250
<b>TEAR RESISTANCE WEFT</b> dIN 53363 (N) > 220
<b>PEELING TEST</b> dIN EN ISO 2411 130 N/50mm
<b>FDA COMPLIANCE CEE</b> Yes
<b>SPECIFIC USE</b> cleanrooms, clinical, hospital
<b>ASSOCIATION</b> <b>DynamicRoll</b>

#### Disclaimer

The information contained in this document describes the features of the BMP EUROPE product as tested in a laboratory, other indications excepted, environment at a temperature of +23 degrees °C at 50% relative humidity. It does not necessarily reflect the conditions of industrial use and it does not guarantee the product to be suitable for certain applications. The client remains liable for the proper selection and correct use of the BMP EUROPE product. BMP EUROPE cannot be held responsible should damages arise from the use of its products. Necessary alterations to this data can be made without prior notice.

# OPTIONAL ACCESSORIES



## RADAR



OPENING POINTING RADAR  
TOF/SPOT  
for internal use only



INFRARED RADAR  
with cross-movement  
adjustment



INFRARED RADAR  
motion and presence  
(pedestrian/forklift) radar

## TRAFFIC LIGHTS



GREEN FIXED STANDARD  
traffic light



RED FIXED STANDARD  
traffic light



LED TRAFFIC LIGHT  
with countdown

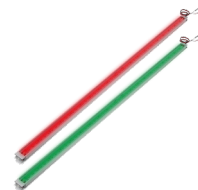

LED TRAFFIC LIGHT BARRIERS  
(connection card included)

## BUTTONS



OPENING GREEN BUTTON  
with box



OPENING BLACK BUTTON  
with box



FREEZE STOP BUTTON  
with box



NO TOUCH BUTTON



TRAFFIC LIGHT BUTTON  
DUAL-FUNCTION  
opening and  
intermittent door  
opening/closing  
signaling



WIND GAUGE



KEY SELECTOR



REMOTE CONTROL



BOLLARD B-PROTECT



PULL CORD SWITCH



MAGNETIC LOOP DETECTOR

**w.w.Cannon, Inc.**

**Design. Layout. Build. Install.**

1-800-442-3061

[www.wwcannon.com](http://www.wwcannon.com)