

# Crossover Stairs

The Safe Way to Move Over Objects

Meets OSHA Requirements

1910.25, 1910.28, 1926.451(f) (16)  
& ASCE 7-10 table 4-1 for catwalks

## Features:

- Modular design bolts together quickly
- Durable galvanized finish for long life
- Continuous handrail system for exceptional safety
- Heavy duty steel components for durability and stability
- High traction walking surfaces for greater safety
- Ships flat for lower freight costs
- Fully OSHA compliant system delivers confidence

## Modular Components

Garlock Safety's crossover stairs is a modular system featuring stair sections with high traction treads, 36" square work platforms and a continuous handrail design. These components can be used to create numerous unique configurations for your facility. The components lay flat in a box for lower shipping costs.

## Easy On-Site Assembly

Components bolt together using simple hand tools. Assembling the treads to the stringers and attaching them to the platform is fast and easy work. Handrails use simple set screws to build the OSHA compliant handrail system.

## Unique Versatility

From two up to seven treads can be set into the stringers for clearing objects of many heights. Then, up to three 36" platforms can be attached to each other without the use of additional support towers.

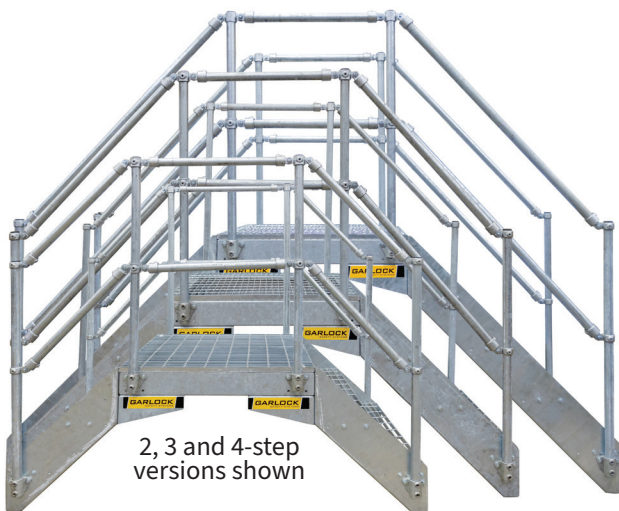

2, 3 and 4-step  
versions shown

## Why Choose Garlock?

- Rigorously Tested to Exceed OSHA & ANSI Standards
- In-House Engineering
- 100+ Years of Industry Experience
- Full Passive Fall Protection Portfolio
- Custom Engineered Products Available

# Features

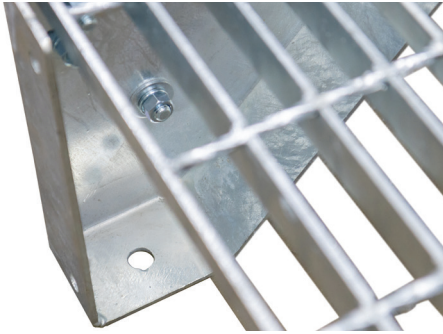

Integrated holes for customer provided anchors.

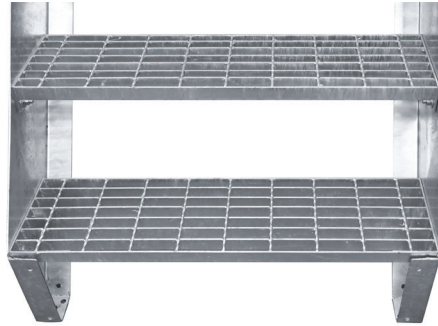

Heavy duty treads with high traction for safety.



Platform gussets add extra strength and stability.

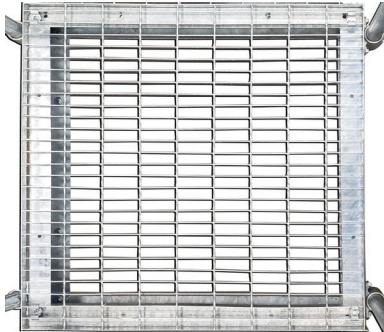

Heavy duty slip resistant grating on 36" X 36" working surface.

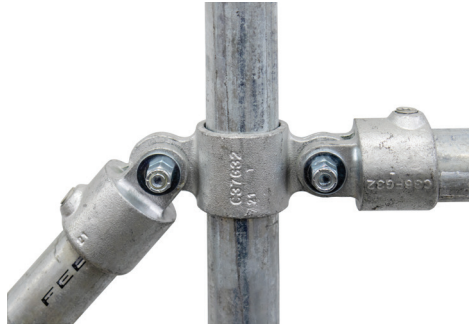

Simple bolts and set screws to construct OSHA compliant handrail.



Continuous handrail system for increased safety.

# Specifications

Component material	Hot dipped galvanized steel
Max number of treads	Seven treads before platform attachment required
Number of platforms without vertical support member	Three 36" platforms for 9' of linear clearance
Tread dimensions	9.625" depth, 36" wide, 1.25" high with 9.5" spacing between treads
Anchoring	Holes provided for customer supplied anchors
Pipe material	1.25" schedule 40 hot dipped galvanized pipe
Fittings	Hot dipped galvanized with set screw and bolt attachment
Hand rail height	42" top rail, field installed mid-rail at 20"
Product weights	2-step weighs 395 lbs., 3-step weighs 485 lbs., 4-step weighs 575 lbs.

Due to continuous improvement, specifications are subject to change without notice.



76.75"  
430-212-600  
2-step platform



95.75"  
430-313-600  
3-step platform

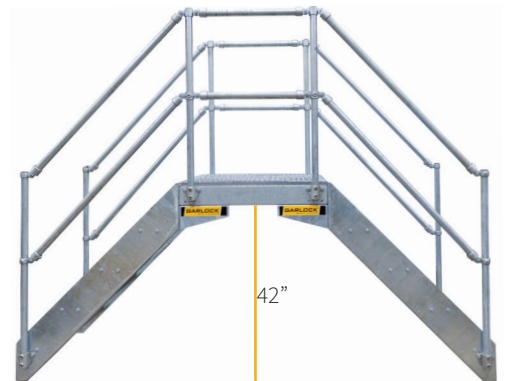

114.75"  
430-414-600  
4-step platform