

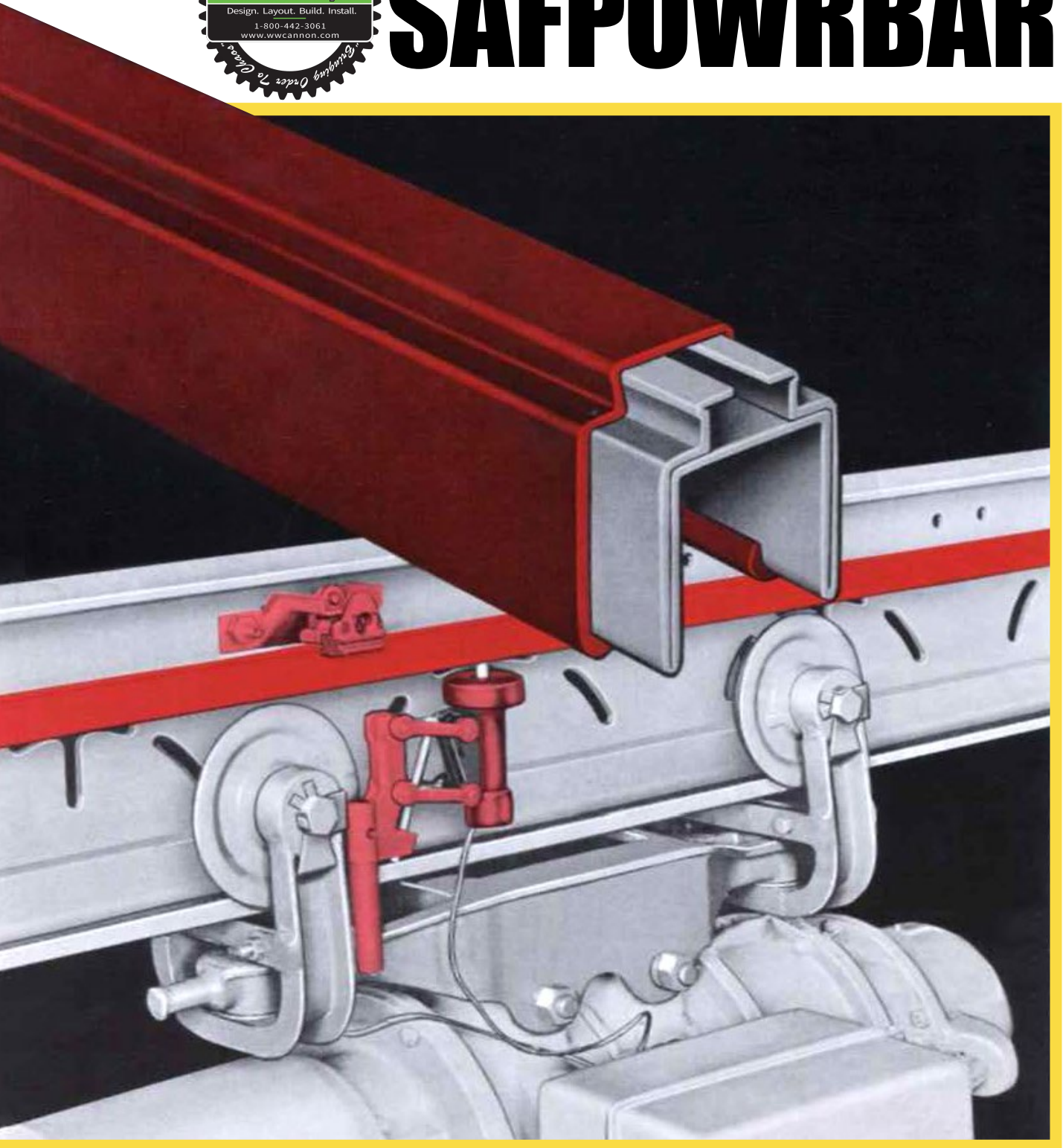

# SAFPOWRBAR®



*CLEVELAND*



*TRAMRAIL*  
By Gorbels Inc.

- Double insulation helps eliminate electrical leaks:
  - Conductor bars are covered with an orange, flame-resistant cover.
  - Conductor bars are supported by fiberglass molded insulators.
- Inverted, U-shaped conductor bars enclose the sliding collector shoe on 3 sides, minimizing dirt accumulation.
- Conductors made in one standard size, with:
  - galvanized steel (standard), rated for loads up to 140 amps.
  - stainless steel, rated for 75 amps.
  - copper, rated for 300 amps.
- End caps - current taps - interlock and covers - and couplings on the conductor are substantially insulated with neoprene rubber.
- The sliding collector shoe is made of powdered bronze, which has lubricating properties.
- Diagonal and torsion springs provide solid contact between the shoe and all 3 sides of the conductor bar.
- Sliding shoes are easily inserted or removed at any point in the conductor system.
- Pantograph movement maintains sliding shoe in a horizontal position at all times.
- Large electrical contact areas, totaling about 2.7 sq. in., reduces arcing and increases the life of the shoe.

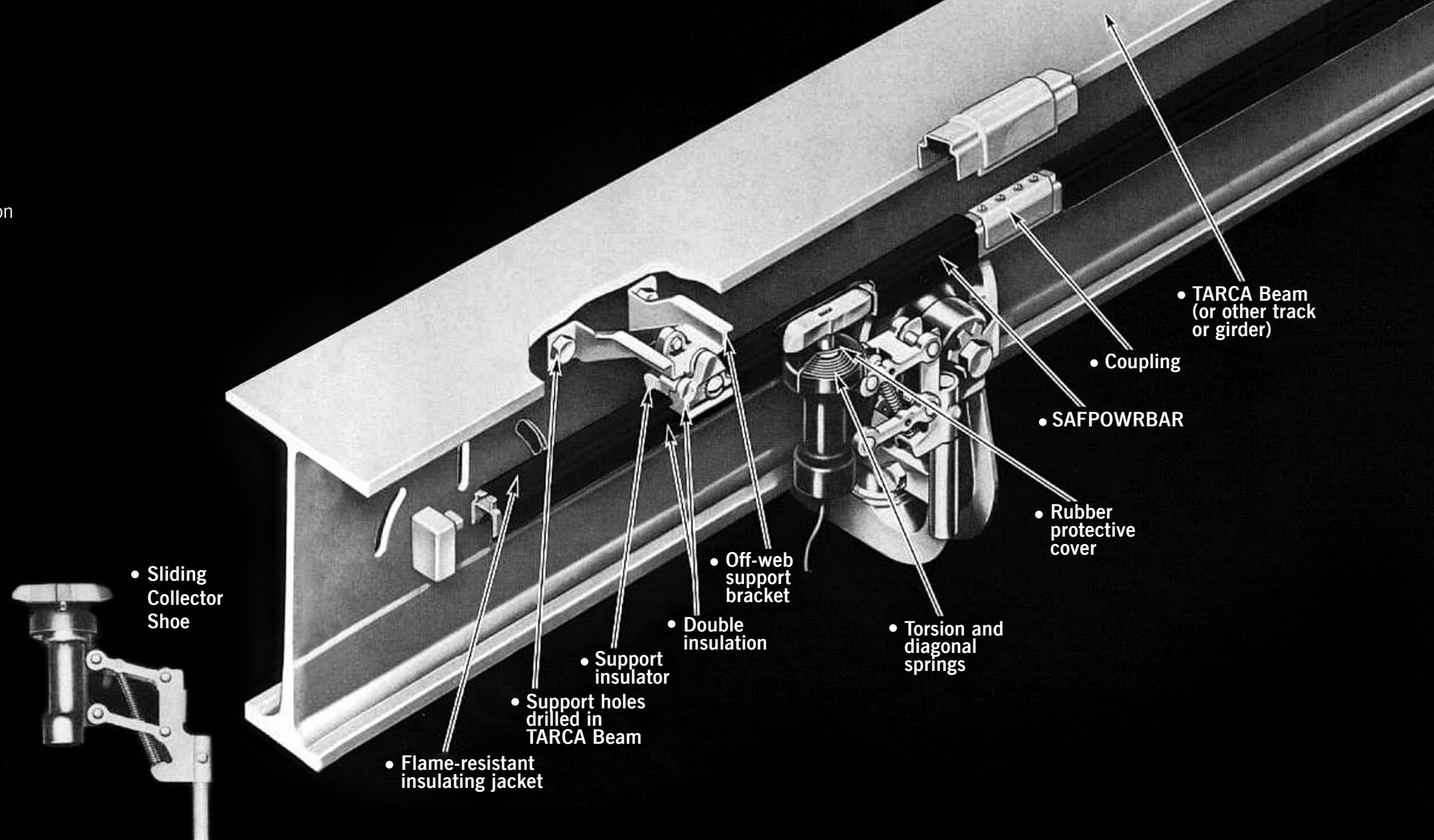

## These SAFPOWRBAR features benefit you in important ways.

**Safer.** The safety of personnel and equipment is always uppermost in our design considerations. SAFPOWRBAR conductor systems provide safer electrification through double insulation and careful design standards. Hundreds of miles of travel, across millions of feet of SAFPOWRBAR apparatus, offer proof of this safer approach to overhead materials handling. This safety has been demonstrated in various hard-service applications at many installations.

**More trouble-free service.** SAFPOWRBAR electrification reduces maintenance and provides assurance against power interruptions. Continuous electrical contact is made possible by large contact areas on the 3 sides of the conductor bar. Plus, the pressure exerted on these 3 sides is only 3½ pounds.

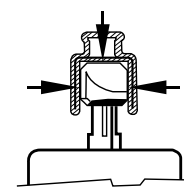
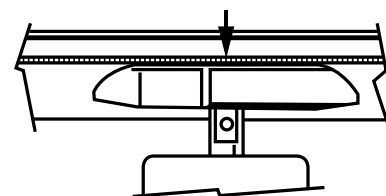

With SAFPOWRBAR you get a compact, easily replaceable, and relatively inexpensive collector assembly. SAFPOWRBAR curves are furnished from the factory. SAFPOWRBAR systems are easily installed on Cleveland Tramrail equipment as TARCA® Track is pre-drilled to accept components. They can also be easily installed on other crane and material handling systems.

**Longer life.** Test installations have proven that the sliding collector shoe in a SAFPOWRBAR conductor lasts longer because the larger surface means less arcing and longer service life. In addition, the orange insulating jacket is designed for maximum service life and minimum shrinkage, even in high temperature areas.

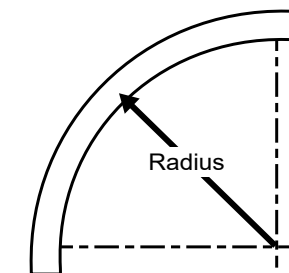



### Fiberglass Support Insulators

Support insulators are made of molded fiberglass reinforced alkyd polyester. Fiberglass has great strength and is high dielectrically. It will withstand abnormal temperatures and is unaffected by moisture and most acid vapors. Insulators are available for supporting either one or two SAFPOWRBAR conductors.

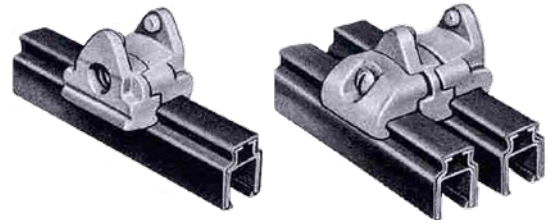

### Conductor Bar Support Options

For 8" and 8" TARCA Track (Carriers with wheels of 5" diameter or less). This support is clamped directly to the top flange of the track. It can accommodate one to four conductor bars on each side.

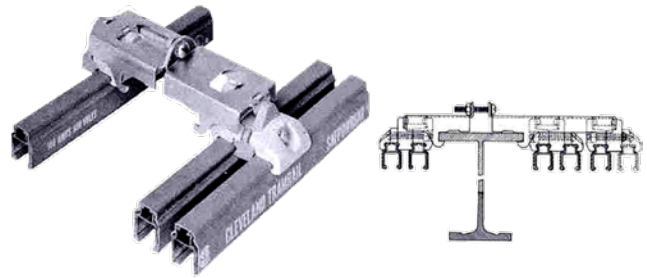

### Off-Web Conductor Bar Supports (For all 10" TARCA Track and larger)



Support bracket for two single-bar or two double-bar insulators, or one of each.

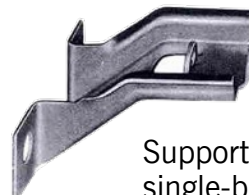

Support bracket for either one single-bar or one double-bar insulator.

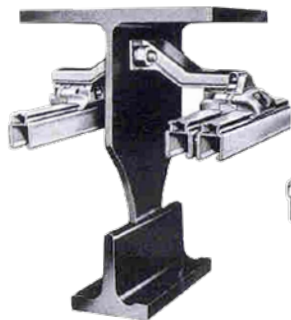

Turned Down Position

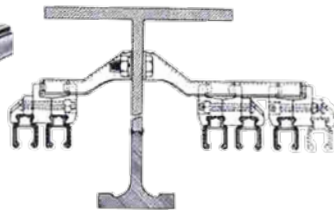

Turned Up Position

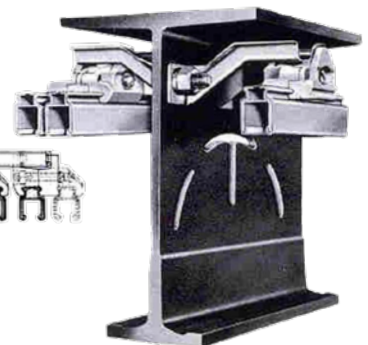
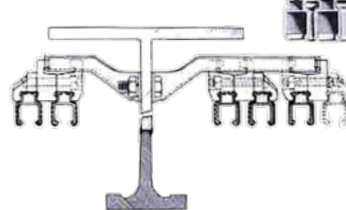

Steel brackets, which mount directly on the track web, support conductors on 10" and larger TARCA Track. These supports can be turned up or down, depending on track depth and wheel size. One to six conductors can be held by the off-web supports.