



HIGH
SPEED
DOORS



DynamicRoll[®]
MS150

TECHNICAL DATA



HIGH SPEED
Up to 1,8 m/s



PROTECTION



OIL FREE



SAFE

DynamicRoll® **MS150** is a roll up door for applications where a protective mechanical barrier is needed to protect machineries and automated lines. Equipped with a **safety micro switch** installed in the bottom part of column (accessible), that assures a signal of door closed separately to the control panel.

The curtain is equipped with lateral zippers that assures the sealing of all door columns full height, for ideal protection.

- The door complies with the machinery directive **2006/42/EC** and the directive **2014/30/EU (EMC)**.
- Safety of control circuits **PL D (Performance Level)** according to **EN 13849-1** or **SIL 2 (Safety Integrity Level 2)** according to **IEC 62061**.



MAXIMUM DIMENSIONS	W 6.000 mm x H 5.000 mm
SPEED	Max opening speed Up to 1,8 m/s
	Closing speed 0,8 m/s
CYCLES TEST	1.000.000
WIND RESISTANCE	3.000 x 3.000 Class 4
STRUCTURE	Not self-supporting
FRAME / MOTOR COVER HOOD	Standard Galvanized steel
	Optional <ul style="list-style-type: none"> • Powder coated steel • Stainless steel 441/316
CURTAIN	Standard PVC curtain 1.300 g/m ² , 6 W/m ² K
	Optional <ul style="list-style-type: none"> • Translucent 35/40% • FDA (white) • Antistatic
CONTROL PANEL	Standard Powder coated steel box IP54 (300 x 500 x 150 mm)
	Optional <ul style="list-style-type: none"> • Stainless steel • PVC box IP65 (300 x 400 x 150 mm)
	Inverter system 50/60 Hz with absolute encoder
	Power supply 1-ph, 230V max 16A
	Power supply 3-ph, 400V max 10A
	Power supply 3-ph, 230V max 16A
	Start/ Stop button
	2 free contacts (door open / closed / alarm)
	Automatic / Manual Interlocking between 2 doors
	IP rating for motor and control panel IP54
WIRING	Plug and Play IP65 system
SAFETIES	Standard Multi ray light curtain barrier H 2500 IP67
EMERGENCY OPENING	Standard Hand crank
	Optional <ul style="list-style-type: none"> Chain system Counterweight system UPS battery
ADVISING OPERATIVE TEMPERATURE	Operating till -30 C°* with heating kit added - Not apt to be installed in negative/positive temperature

EN13241 CERTIFICATION

STANDARD	REF.	TEST ACC.	RESULTS
WATER PERMEABILITY	EN 12425	EN 12489	Class 2
WIND LOAD	EN 12424	EN 12444	Class 4
AIR PERMEABILITY	EN 12426	EN 12427	Class 1
SAFE OPENINGS	EN 12453	EN 12445	✓
MECHANICAL RESISTANCE	EN 12604	EN 12605	✓
UNINTENDED MOVEMENTS	EN 12604	EN 12605	✓
THERMAL TRANSMITTANCE	EN 12428	EN 12428	6,02 W/m²K
PERFORMANCE (CYCLES)	EN 12604	EN 12605	1.000.000

Values can change depending on door dimensions

IMPACT TEST

EN ISO 14120
CERTIFICATION

100 x 6
KG KM/H

Tested
impact
energy **115**
JOULES
(Annex C - C.2.5.1)

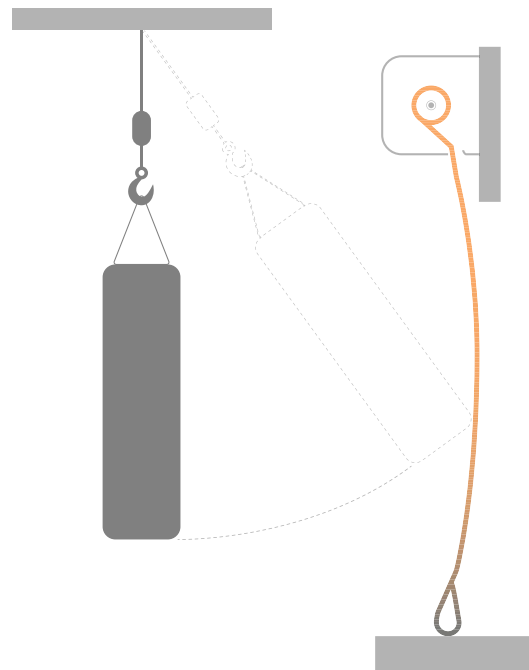

APPLICATIONS



Industry, automated production lines



Conveyor lines

DOOR SPACE REQUIREMENTS

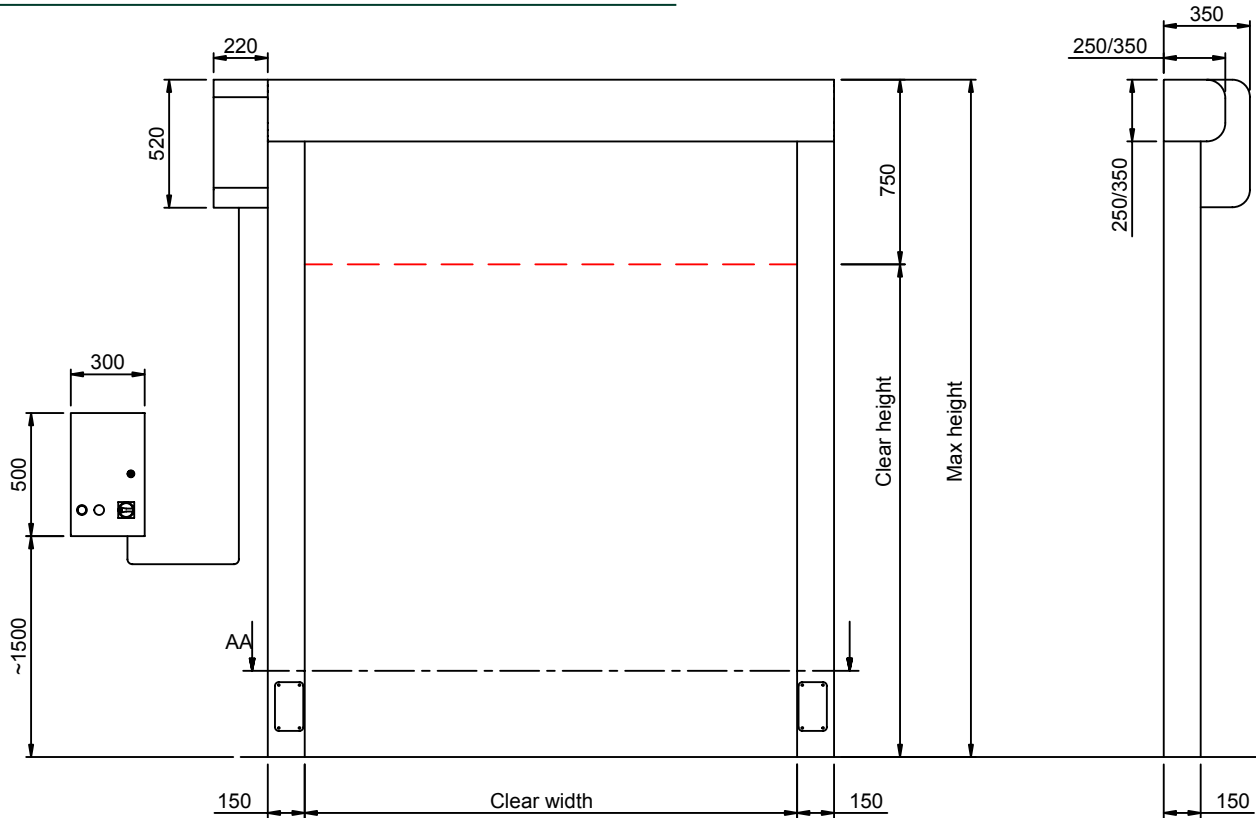

SECTION A-A

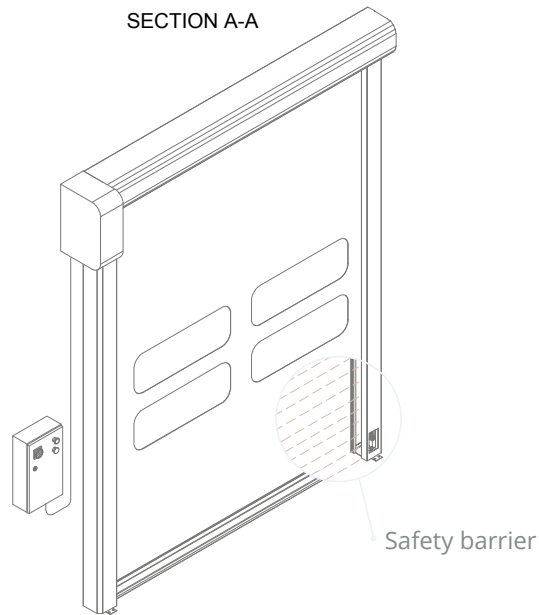

FIXING DETAILS



PVC CHARACTERISTICS

STANDARD PVC

Composition and tests

EXTERNAL SIDE			
Material	Finishing	Color	Thick
PVC	Opaque	18 standard	0,7 mm
FABRIC			
Material	N. tarps	Title	EN 2286-2
PES	1	1100Dtex 12x12	900 g/m ²
INTERNAL SIDE			
Material	Finishing	Color	Thick
PVC	Rough	18 standard	0,2 mm
COLD RESISTANCE ISO 4675/90 -50°C ±5			
HYDROLYSIS TEST 75°C 95% humidity none variation			
GAS OIL TEST - none variation			
MARINE WATER TEST - none variation			
OZONE TEST ISO 3011 none crack			
T. STORAGE (°C) -30 +65			
FLAME TEST ISO 3795 < 100 mm/min			
PERFORATION RINA 3.A7.2.7 (N) > 100			
EXERCISE 7 days -70°C ISO 6065 none variation			

Characteristics

THICK ISO 2286/3 (mm) 0,9±0,1
WEIGHT ISO 2286/2 (kg/m ²) 0,90±0,1
LOAD BREAK ISO 1421 6000 N/50mm
WARP EXTENSION ISO 1421 4300 N/50mm
TEXTURE EXTENSION ISO 1421 4000 N/50mm
WARP BREAK dIN 53363 (N) > 600
TEXTURE BREAK dIN 53363 (N) > 530
ADHESION dIN EN ISO 2411 130 N/50mm
EEC CONFORMITY - Yes
SPECIFIC USE industry, refrigerators, car washes, supermarkets, warehouses
ASSOCIATION -

Colors



Antistatic available

FDA (Food Drug Administration) certified pvc available

INSULATED PVC

Composition and tests

EXTERNAL SIDE			
Material	Finishing	Color	Thick
PVC	Straight	6 standard	0,5 mm
FABRIC			
Material	N. tarps	Title	EN 2286-2
PES	1	1100Dtex 12x12	1350 g/m ²
INTERNAL SIDE			
Material	Finishing	Color	Thick
PVC	Sponge	6 standard	7 mm
COLD RESISTANCE ISO 4675/90 -10°C ±5			
HYDROLYSIS TEST 75°C 95% humidity none variation			
GAS OIL TEST - none variation			
MARINE WATER TEST - none variation			
OZONE TEST ISO 3011 none crack			
T. STORAGE (°C) -30 +65			
FLAME TEST ISO 3795 cl 2, NFPA 701 test 2			
PERFORATION RINA 3.A7.2.7 (N) > 100			
EXERCISE 7 days -70°C ISO 6065 none variation			

Characteristics

THICK ISO 2286/3 (mm) 7,0±0,1
WEIGHT ISO 2286/2 (kg/m ²) 1,7±0,1
LOAD BREAK ISO 1421 6000 N/50mm
WARP EXTENSION ISO 1421/V1 3000 N/50mm
TEXTURE EXTENSION ISO 1421/V1 2800 N/50mm
WARP BREAK dIN 53363 300 N
TEXTURE BREAK dIN 53363 300 N
ADHESION PA 09.03 (internal) 15 N/cm
THERMAL CONDUCTIVITY - 0,03782 W.m ⁻¹
ISOLATION INDEX - Rw= 17,5 dB
EMPLOYMENT industry, refrigerators, car washes, supermarkets, warehouses
ASSOCIATION -

Colors

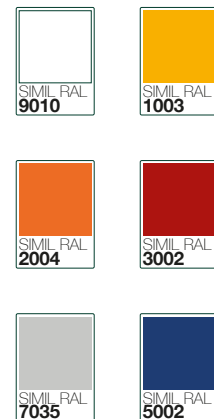

CRISTAL CHARACTERISTICS

PVC SUPERCLEAR

! SUITABLE ONLY FOR POSITIVE TEMPERATURE ENVIRONMENTS

WINDOWS - CRISTAL TECHNICAL DATA

Article	SUPERCLEAR 1.2 mm FR
---------	----------------------

Technical specifications	Standards	Unit	Values
Thickness	-	mm.	1.2
PVC total weight	-	g/m ²	1200
Light transmission	JIS K - 7361	%	97.3
Tensile strength <i>Lengthwise MD</i>	JIS K - 6732	N	26.1
Tensile strength <i>Crosswise TD</i>	JIS K - 6732	N	24.3
Tear strength <i>Lengthwise MD</i>	JIS K - 6732	N	63.4
Tear strength <i>Crosswise TD</i>	JIS K - 6732	N	63.9
Elongation <i>Lengthwise MD</i>	JIS K - 6732	%	377
Elongation <i>Crosswise TD</i>	JIS K - 6732	%	378
Cold crack resistance	JIS K - 6772	°C	-45

OPTIONAL ACCESSORIES

RADAR



OPENING POINT
RADAR TOF/SPOT
for internal use only



INFRARED RADAR
with cross-movement
adjustment



INFRARED RADAR
motion and presence
(pedestrian/forklift) radar

TRAFFIC LIGHTS



GREEN FIXED STANDARD
traffic light



RED FIXED STANDARD
traffic light



LED TRAFFIC LIGHT
with countdown



LED TRAFFIC LIGHT
BARRIERS
(connection card included)

BUTTONS



OPENING GREEN
BUTTON
with box



OPENING BLACK
BUTTON
with box



FREEZE STOP
BUTTON
with box



NO TOUCH
BUTTON



TRAFFIC LIGHT
BUTTON
DUAL-FUNCTION
opening and
intermittent door
opening/closing
signaling



WIND GAUGE



KEY SELECTOR



REMOTE CONTROL



BOLLARD B-PROTECT



PULL CORD SWITCH



MAGNETIC LOOP DETECTOR

w.w.Cannon, Inc.

Design. Layout. Build. Install.

1-800-442-3061
www.wwcannon.com