

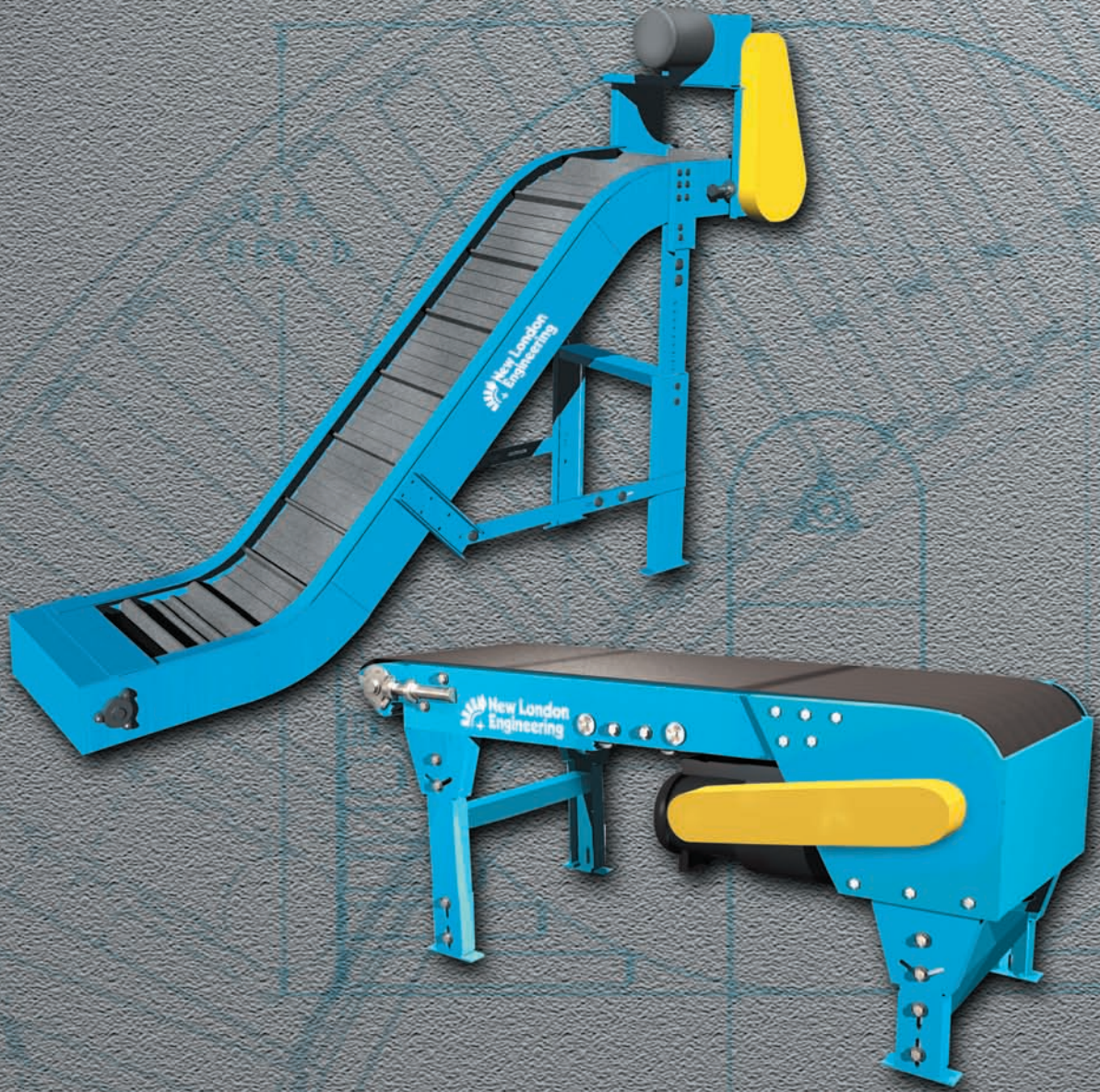

# New London Engineering

Quality Conveyors Since 1948



## General Catalog



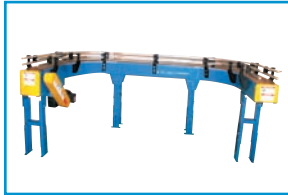

**PlastiTrak**  
Plastic Belt Conveyors  
Page 1

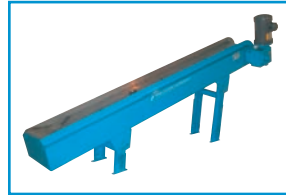

**Magnetic Conveyors**  
Page 8



**ToughTrak**  
Low Profile Conveyors  
Pages 2-3



**Drag Conveyors**  
Page 8



**Horizontal Conveyors**  
Slider Beds  
Page 4

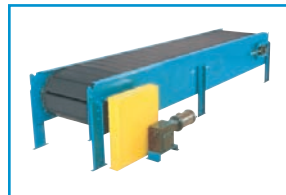

**Slat Conveyors**  
Page 8



**Floor to Floor Conveyors**  
Page 5

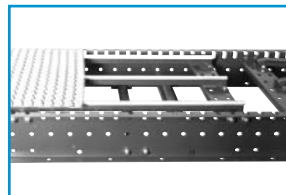

**Wire Mesh Conveyors**  
Page 8



**Turntable Conveyors**  
Page 5



**Gravity Rollers**  
Page 9



**Inclined Cleated Belt Conveyors**  
Page 6



**Pallet Dispenser**  
Page 9

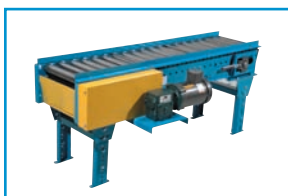

**Belt Driven Live Roller**  
Page 7



**Power Belt Curves**  
Page 9



**Chain Driven Live Roller**  
Page 7

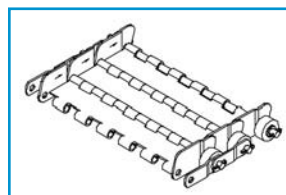

**Hinged Steel Belts**  
Page 10

# PlastiTrak Plastic Belt Conveyors

## PlastiTrak – Model 1000 and Model 2000 Comparison Chart

MODEL	FRAME GAUGE / DEPTH	BELT WIDTHS	FRAME WIDTHS	FRAME SPREADER	SHAFTS	TYPICAL PRODUCTS	RETURN ROLLERS	COMMON INDUSTRY DEFINITIONS
1000	12 gauge 6-11/16" deep	Narrow widths (Typically 12" and less)	BW + 1/2"	12 gauge formed angle (one bend)	1-3/16" round shafts	Cans & bottles (Bottling plants)	2" x 7/16" hex	Table top
								Chains
2000	10 gauge 7-5/8" deep	Wider widths (Widths range from 12" up to 100+)	BW + 7/8"	10 gauge formed channel (two bends)	1-1/2" square shafts	Cases, boxes and pallets (Production & Manufacturing Operations)	2-1/2" x 11/16" hex	Mat top
								Belts



**Model  
1000-S**



**Model  
1000-C**

The Model 1000 plastic belt conveyors are typically used to convey lighter products like bottles and cans. Since the live loads for these applications are typically lighter, light construction features including a 12-gauge frame are standard. These units are common in bottling operations, dairies and pharmaceutical plants.



**2000-S**

### General Transport Applications

This unit is designed for low cost, general transport applications in light duty production and packaging operations.



**2000-S**

### Accumulation Applications

This unit is designed for accumulations of products ranging from boxes of candy or laundry detergent to accumulations of irregular shaped products like newspapers or magazines.



**2000-C**

This unit is used in production and packaging operations requiring a right hand or left hand curve.



**2000-CF**

This unit is designed for applications that require curves and an elevation change.



**2000-F**

This unit uses flights (cleats) to transport small unboxed products like plastic parts, nuts, bolts, plastic bottles, cans or stampings.



**2000-N**

This unit is designed to carry boxes (packaged items) up inclines or down declines.

# ToughTrak Tough & Durable Low-Profile Conveyors

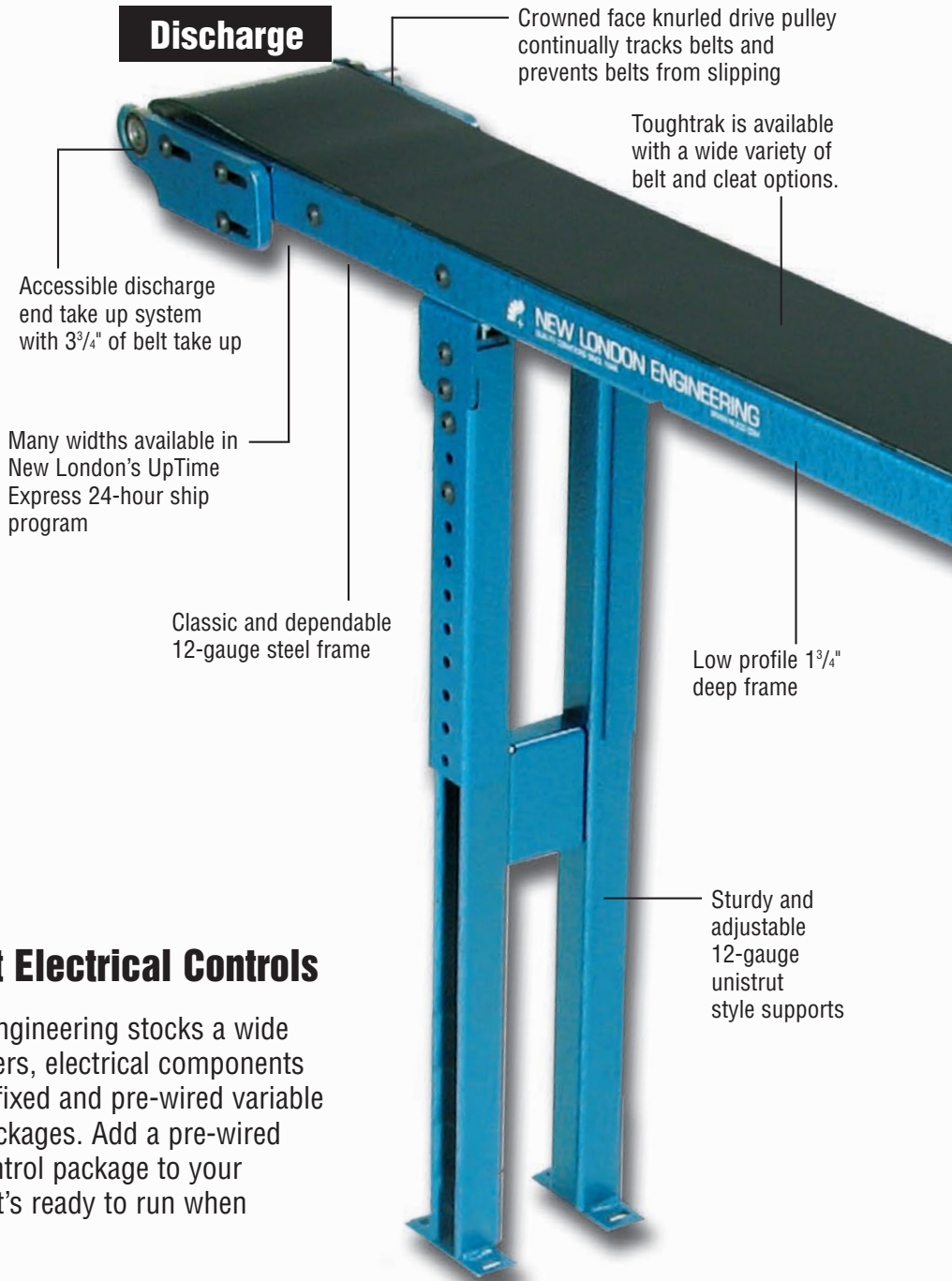

**Discharge**

Crowned face knurled drive pulley continually tracks belts and prevents belts from slipping

Toughtrak is available with a wide variety of belt and cleat options.

Accessible discharge end take up system with 3<sup>3</sup>/<sub>4</sub>" of belt take up

Many widths available in New London's UpTime Express 24-hour ship program

Classic and dependable 12-gauge steel frame

Low profile 1<sup>3</sup>/<sub>4</sub>" deep frame

Sturdy and adjustable 12-gauge unistrut style supports

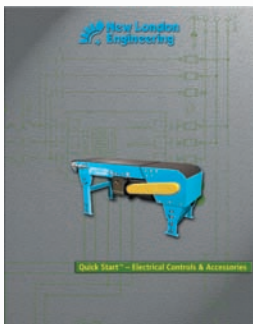

## Quick Start Electrical Controls

New London Engineering stocks a wide variety of starters, electrical components and pre-wired fixed and pre-wired variable speed drive packages. Add a pre-wired Quick Start control package to your conveyor and it's ready to run when it arrives.

### ToughTrak Common Features

FRAME	INFEED PULLEY	DRIVE PULLEY FACE	STANDARD BELT	SUPPORTS
12 Gauge x 1 <sup>3</sup> / <sub>4</sub> " deep (Frame width is BW + 31/32")	1 <sup>5</sup> / <sub>16</sub> " Diameter Flat Face x 1/2" Bore	Crown Face Knurled	2-Ply Black PVC with #36 Unibar Lacing	Adjustable 12 Gauge Unistrut

# ToughTrak Tough & Durable Low-Profile Conveyors

## Design and Construction Features

ToughTrak low profile conveyors are lean and mean working machines. These steel fabricated, tough and durable conveyors are built to survive the extreme tests of the manufacturing environment. ToughTrak is not only built to last, they can be built to your exact length and width specifications at a cost lower than any other low profile conveyor.

ToughTrak Low Profile Conveyors are American made and American engineered to work harder and last longer than any competitor in its class. That's why they are called ToughTrak!

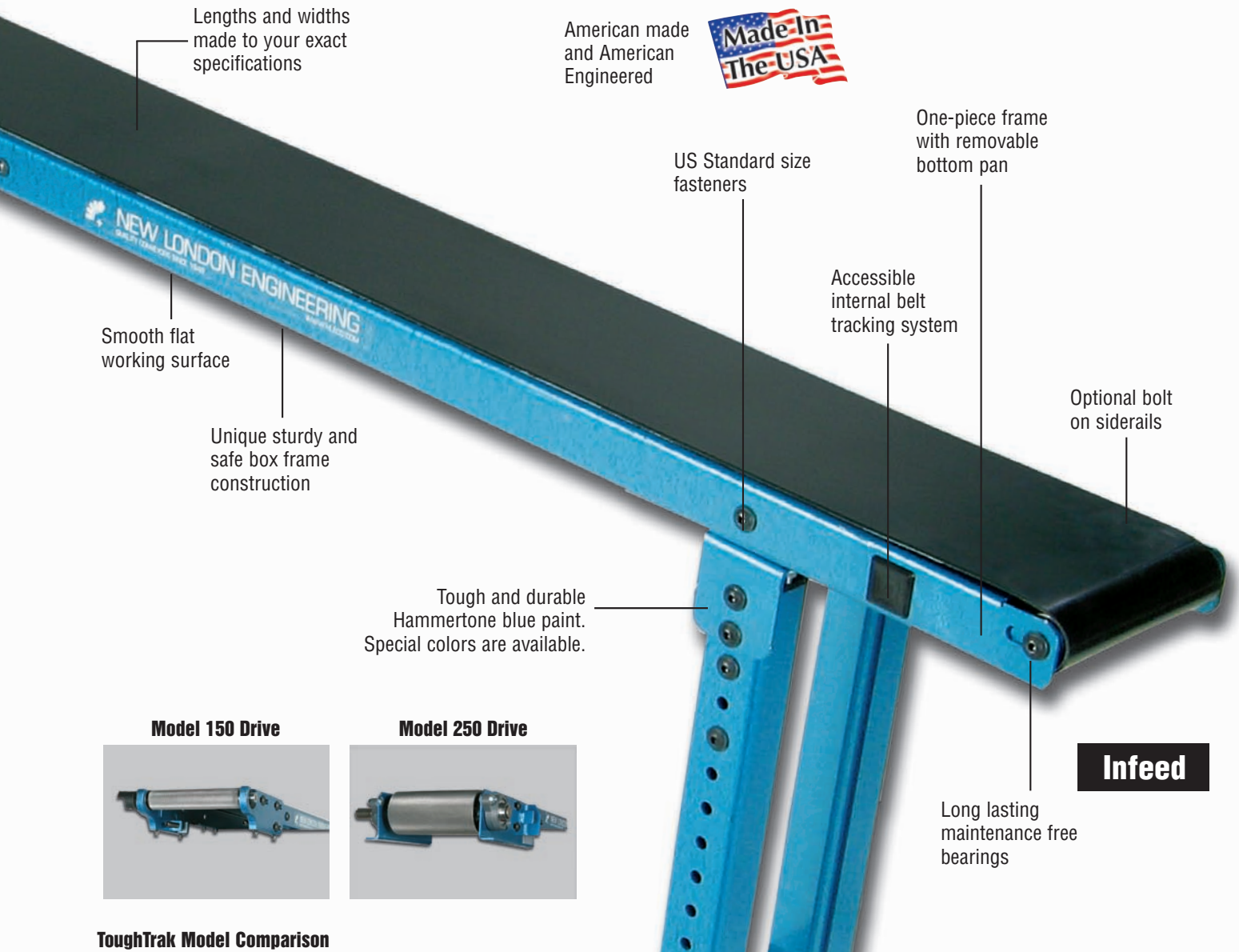

**Model 150 Drive**



**Model 250 Drive**



### ToughTrak Model Comparison

MODEL	APPLICATION	DRIVE PULLEY DIA.	DRIVE PULLEY BORE	DRIVE PULLEY BEARING	DRIVE PULLEY HEAD PLATE	DRIVE-MOTOR	TAKE UP/TRACKING
<b>Model 150</b>	Standard Duty Low Profile Applications	1 <sup>5</sup> / <sub>16</sub> "	5/8"	Pressed in Precision Bearings	Machined 1/2" Thick	Gearmotors	Internal @ Infeed Internal @ Discharge
<b>Model 250</b>	Heavy Duty Low Profile Applications	2 <sup>7</sup> / <sub>8</sub> "	3/4"	2 Bolt Flanged Grease Sealed	10 Gauge Formed	Motor-Reducer Combinations with 56 C Frames	Internal @ Infeed External @ Discharge



# Horizontal Conveyors Slider Beds

**Model 200**



- This shallow frame conveyor can fit into tight spaces other slider beds can't.
- Designed for shorter run, lightweight applications.

**Model 210**



- Built for low maintenance operations in medium duty length and weight applications.

**Model 220 & 221**



- This sturdy, solid heavy duty conveyor is built for longer, wider and heavier weight applications.

## Horizontal Conveyor Comparison Chart

**Horizontal Conveyors** — These units are used to convey everything from boxes to small pallets.

MODEL	DESCRIPTION	FRAME GAUGE	FRAME DEPTH	DRIVE PULLEY SIZE	DRIVE PULLEY TYPE*	DRIVE SHAFT DIA.	INFEED PULLEY SIZE	INFEED PULLEY TYPE*	INFEED PULLEY SHAFT DIA.	STANDARD BELT	STD. DRIVE	OTHER
200	Standard duty slider bed	12	2.75"	4.625"	CFRL pulley	1.1875"	4"	CF pulley	1.1875"	2 ply black PVC 120	Bottom	Base length = 5'
210	Medium duty slider bed	12	2.75"	8.625"	CFRL pulley	1.4375"	4"	CF pulley	1.1875"	2 ply black PVC 120	Bottom	Base length = 5'
220	Medium – heavy duty slider bed	12	5.5"	8.625"	CFRL pulley	1.4375"	4"	CF pulley	1.1875"	2 ply black PVC 120	Bottom	Base length = 5'
221	Heavy duty slider bed	12	5.5"	8.625"	CFRL pulley	1.6875"	4"	CF pulley	1.4375"	2 ply black PVC 120	Bottom	Heavy shaft M220
301	Standard duty V-guided slider bed	12	6.625"	4.625"	FFRL "A" section	1.1875"	4"	FF "A" section	1.1875"	2 ply black PVC 120 "A" section V-guided	Bottom	V-guided deep frame M200
311	Medium duty V-guided slider bed	12	6.625"	8.625"	FFRL "A" section	1.4375"	4"	FF "A" section	1.1875"	2 ply black PVC 120 "A" section V-guided	Bottom	V-guided deep frame M220
321	Heavy Duty V-guided slider bed	12	6.625"	8.625"	FFRL "A" section	1.6875"	4"	FF "A" section	1.4375"	2 ply black PVC 120 "A" section V-guided	Bottom	Heavy shaft M311
640	Heavy duty belt over roller bed	12	6.5"	8.625"	CFRL pulley	1.4375"	4"	CF pulley	1.1875"	2 ply black PVC 120	Bottom @ dis.	Rollers – 2" dia. x 16 ga. x .4375" hex on 6" centers

\*BM = Bottom Mount; CF = Crown Faced; CDBM = Center Drive Bottom Mount; CH = Channel; FF = Flat Faced; RL = Rubber Lagged; RA = Right Angle; Std = Standard

**Model 301**



**Model 311**



- "V" guided conveyor designed for lightweight, side loading and short, but wide applications.

**Model 321**



- "V" guided conveyor designed for heavier weight, side loading and short, but wide applications.

**Model 640**



- Roller bed conveyor designed to carry heavy loads, longer distances.

# Floor to Floor Conveyors

**Model 410**

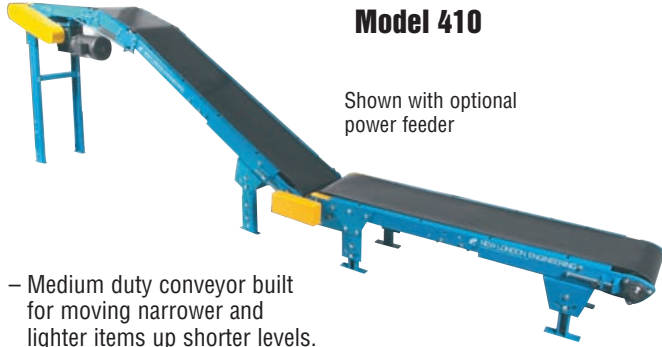

Shown with optional power feeder

– Medium duty conveyor built for moving narrower and lighter items up shorter levels.

**Model 420**

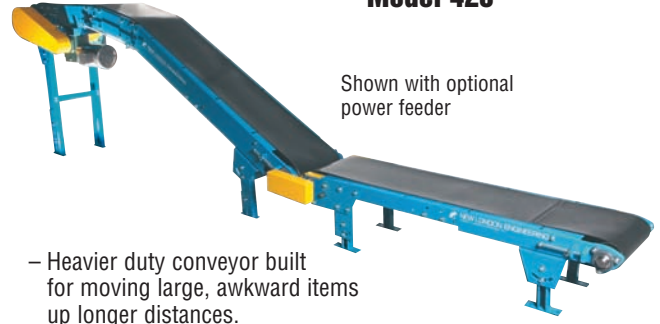

Shown with optional power feeder

– Heavier duty conveyor built for moving large, awkward items up longer distances.

## Floor to Floor Conveyor Comparison Chart

**Floor to Floor Conveyors** — These units are typically used to carry boxes (packaged items) up inclines or down declines. What differentiates these units from cleated belt conveyors are its **cost, belt and a nose-over feature.**

MODEL	DESCRIPTION	FRAME GAUGE	FRAME DEPTH	DRIVE PULLEY SIZE	PULLEY PULLEY TYPE*	DRIVE PULLEY SHAFT DIA.	INFEED PULLEY SIZE	PULLEY PULLEY TYPE*	INFEED PULLEY SHAFT DIA.	STANDARD BELT	STD. DRIVE*	OTHER
410	Medium duty floor to floor conveyor	12	2.75"	4.625"	CFRL pulley	1.1875"	4"	CF pulley	1.1875"	2 ply 150 black rubber rough top	Bottom	Unit includes an adjustable nose over. Inclines use a M200 frame (Power feeders are optional)
420	Heavy duty floor to floor conveyor	12	5.5"	8.625"	CFRL pulley	1.4375"	4"	CF pulley	1.1875"	2 ply 150 black rubber rough top	Bottom	Unit includes an adjustable nose over. Inclines use a M220 frame (Power feeders are optional)

\*BM = Bottom Mount; CF = Crown Faced; CDBM = Center Drive Bottom Mount; CH = Channel; FF = Flat Faced; RL = Rubber Lagged; RA = Right Angle; Std = Standard

# Turntable Conveyors

**Model 180**

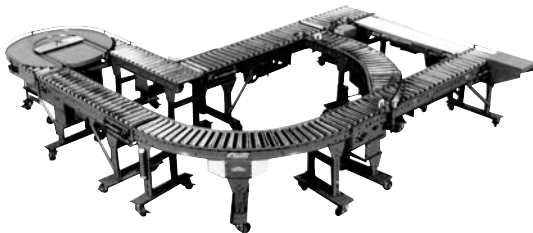

– Typically used in sorting applications and systems requiring a 180 degree turn. These units can turn products 180 degrees in spaces traditional conveyors can't.

**Model 181**



– Used in accumulation or sorting applications. Decks can be made of carbon or stainless steel.

## Turntable Conveyor Comparison Chart

**Turntable Conveyors**

MODEL	DESCRIPTION	FRAME GAUGE	FRAME DEPTH	STANDARD REVOLUTIONS / APPLICATION	RAILS	STANDARD DRIVE	OTHER
180	Directional change turn table	12	2"	2.5 revolutions per minute – Typically used in sorting applications and systems with a 180 degree turn. These units will fit in tight spaces traditional radius curve units can't.	3-1/2" stationary rails	Bottom	Turntables are available in standard 3' – 8' table diameters
181	Accumulation turn table	12	2"	1-3 revolutions per minute – This unit is designed for use in accumulation and sorting applications.	6" rotating rails	Bottom	

# Inclined Conveyors Cleated Belt Conveyors

**Model 500**



– This standard duty conveyor is designed to carry lighter weight and smaller product.

**Model 351**



– Standard duty “V” guided inclining conveyor.

**Model 505 & 506**



– This heavy duty conveyor is designed to move larger and heavier products up inclines.

## Inclined Conveyors – Horizontal Inclined Units Comparison Chart

**Inclined Conveyors – Horizontal Inclined Units** — These units use cleated belts to carry loose, unpacked items like plastic parts, nuts & bolts and stampings up inclines

MODEL	DESCRIPTION	FRAME GAUGE	FRAME DEPTH	DRIVE PULLEY SIZE	DRIVE PULLEY TYPE*	DRIVE PULLEY SHAFT DIA.	INFEED PULLEY SIZE	INFEED PULLEY TYPE*	INFEED PULLEY SHAFT DIA.	STANDARD BELT	STD. DRIVE*	OTHER
150	Standard duty low profile inclining conveyor	12	1.75" + cleat height	2.875"	CF knurled pulley	.75"	1.3125"	FF pulley	.5"	2 ply black PVC 70	Bottom	Note: Frame depth changes with cleat height
500	Standard duty inclining conveyor	12	6.625"	4.625"	CFRL pulley	1.1875"	4"	CF pulley	1.1875"	2 ply black PVC 120 with 1-1/2" cleats on 12" centers	Top	Unit includes 1-1/2" or 3/12" rails and a bottom pan
505	Medium duty inclining conveyor	10	13"	8.625"	CFRL pulley	1.4375"	8"	CF pulley	1.4375"	2 ply black PVC 120 with 3" cleats on 12" centers	Top	Unit includes 6" high siderails
506	Heavy duty inclining conveyor	10	13"	8.625"	CFRL pulley	1.6875"	8"	CF pulley	1.4375"	2 ply black PVC 120 with 3" cleats on 12" centers	Top	Heavy drive shaft M505
351	Standard duty V-guided inclining conveyor	12	6.625"	4.625"	FFRL "A" section	1.1875"	4"	FF "A" section	1.1875"	2 ply black PVC 120 with 1-1/2" cleats on 12" centers "A" section	Top	V-guided M500

\*BM = Bottom Mount; CF = Crown Faced; CDBM = Center Drive Bottom Mount; CH = Channel; FF = Flat Faced; RL = Rubber Lagged; RA = Right Angle; Std = Standard

# Inclined Conveyors S-Shaped Cleated Belt Conveyors

**Model 521**



– Standard duty parts and bulk material handling conveyor.

**Model 361**



– Standard duty “V” guided parts and bulk material handling conveyor.

**Model 590 & 591**

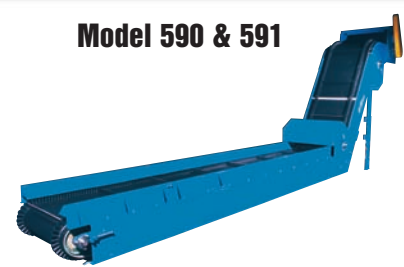

– Medium to heavy duty parts and bulk material handling conveyor.

## Inclined Conveyors Comparison Chart

**Inclined Conveyors – “S” Shaped Units – Horizontal to Incline (Type II) – Horizontal to Incline to Horizontal (Type III) – Incline to Horizontal (Type IV)** — These units use cleated belts to carry loose, unpacked items like plastic parts, nuts & bolts and stampings from a horizontal position up an incline.

MODEL	DESCRIPTION	FRAME GAUGE	FRAME DEPTH	DRIVE PULLEY SIZE	DRIVE PULLEY TYPE*	DRIVE PULLEY SHAFT DIA.	INFEED PULLEY SIZE	INFEED PULLEY TYPE*	INFEED PULLEY SHAFT DIA.	STANDARD BELT	STD. DRIVE*	OTHER
521	Light duty parts or bulk material handling conveyor	12	6.625"	4.5"	CFRL pulley	1.1875"	4"	CF pulley	1.1875"	3 ply RMV with 1-1/2" cleats on 12" centers 1-1/2" wall x 1" cleats for bulk applications	Top	– 1-1/2" or 3/12" side rails – 1-7/8" dia. x 3/4" face hold down wheels – 30°, 45° and 60° inclines std
361	Standard duty V-guided type II, III & IV conveyor**	12	6.625"	4.625"	FFRL "A" section	1.1875"	4.25"	FF "A" section	1.1875"	2 ply black PVC 120 with 1-1/2" cleats on 12" centers "A" section	Top	V-guided M521
590	Medium to heavy duty parts or bulk material conveyor	10	13"	8.625"	CFRL pulley	1.4375"	8"	CF pulley	1.4375"	– 2 ply 150 cross rigid x 3" cleats on 12" centers	Top	(2) 12" diameter x 2" wide deflection hold down wheels – 3" high wall x 2-1/2" cleats for bulk app.
591	Heavy duty parts or bulk material conveyor	10	13"	8.625"	CFRL pulley	1.6875"	8"	CF pulley	1.4375"	– 2 ply 150 cross rigid x 3" cleats on 12" centers	Top	– Heavy drive shaft M590 – (2) 12" diameter x 2" wide deflection hold down wheels – 3" high wall x 2-1/2" cleats for bulk app.

\*BM = Bottom Mount; CF = Crown Faced; CDBM = Center Drive Bottom Mount; CH = Channel; FF = Flat Faced; RL = Rubber Lagged; RA = Right Angle; Std = Standard  
\*\*Type II = Horizontal to Incline; Type III = Horizontal to Incline to Horizontal; Type IV = Incline to Horizontal



# Belt Driven Live Roller Conveyors

**Model 600 & 610**

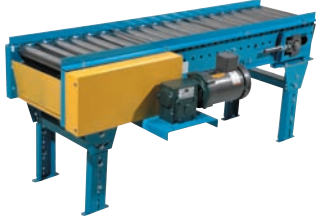

– Used to convey heavier loads like loaded pallets.

**Model 660**

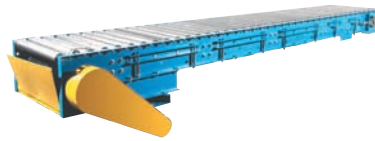

– Variable pressure accumulation conveyor.



**V-Belt Driven Spurs**

– Used to merge production lines.

**V-Belt Driven Curves**



– Used in curved applications.

## Belt Driven Live Roller Conveyor Comparison Chart

**Belt Driven Live Roller Conveyors** — These units are designed to carry heavy products like pallets, drums or tires

MODEL	DESCRIPTION	FRAME GAUGE	FRAME DEPTH	DRIVE PULLEY SIZE	DRIVE PULLEY TYPE*	DRIVE PULLEY SHAFT DIA.	INFEED PULLEY SIZE	INFEED PULLEY TYPE*	INFEED PULLEY SHAFT DIA.	STANDARD BELT	STD. DRIVE*	OTHER
600	Medium duty belt driven live roller	12	6.5"	4.625"	CFRL pulley	1.1875"	4"	CF pulley	1.1875"	2 ply black PVC 120	Bottom @ infeed	Rollers – 2" dia. x 16 ga. x .4375" hex on 6" centers
610	Heavy duty belt driven live roller	12	6.5"	8.625"	CFRL pulley	1.4375"	4"	CF pulley	1.1875"	2 ply black PVC 120	BM @ infeed	Rollers – 2" dia. x 16 ga. x .4375" hex on 6" centers
630 631 645 646 690 691	V-belt drive 30° curve M630 tapered rollers V-belt drive 45° curve M645 tapered rollers V-belt drive 90° curve M690 tapered rollers	12	8"	3.8"	Sheave drive	1.1875"	3.8"	Sheave	1.1875"	V Belt: "B" section drive belt	Bottom @ infeed	V-Belt driven live roller curves  Rollers – 2" dia. x 16 ga. x .4375" hex on 2-5/8" centers inside rail
660	Belt driven live roller with accum. zones	12	6.5"	8.625"	CFRL pulley	1.4375"	4"	CF pulley	1.1875"	2 ply black PVC 120	Bottom @ infeed	Rollers – 2" dia. x 16 ga. x .4375" hex on 6" centers

\*BM = Bottom Mount; CF = Crown Faced; CDBM = Center Drive Bottom Mount; CH = Channel; FF = Flat Faced; RL = Rubber Lagged; RA = Right Angle; Std = Standard

# Chain Driven Live Roller Conveyors

**Model 670 & 675**



– Used to convey very heavy products longer distances.

**2-Strand Chain Conveyor**



– Used to convey heavy and larger sized products.

## Chain Driven Live Roller Conveyors Comparison Chart

**Chain Driven Live Roller Conveyors** — These units are designed to carry heavy products like loaded pallets, filled drums or large tires

MODEL	DESCRIPTION	FRAME GAUGE	DRIVE FRAME DEPTH	PULLEY SIZE	DRIVER	SHAFT	CHAIN & SPROCKET	STD. DRIVE	OTHER
670	Medium duty chain driven live roller	7	6.5"	2.5"	Roller	0.688" hex	#60A 16 x 2-1/2" bore sprocket	Bottom	Rollers – 2-1/2" – 11 ga. x 0.6875" hex on 6" centers. Maximum live load is 19,000#
675	Heavy duty chain driven live roller	1/4"	8"	3.5"	Roller	1.063" hex	#60A 20 x 3-1/2" bore sprocket	Bottom	Rollers – 3-1/2" x .300 wall 1.0625" hex on 6" centers. Maximum live load is 30,000#

# Magnetic, Drag & Slat Conveyors

**Model 700  
Magnetic Conveyor**



– Used to convey very small metal particles or metallic sludge.

**Model 711 & 716  
Drag Conveyor**



– Used to convey very small fine chips and turnings.

**Model 770  
Slat Conveyor**



– Used to convey large, heavy products like washing machines.

## Magnetic, Drag & Slat Conveyor Comparison Chart

MODEL	DESCRIPTION	FRAME GAUGE	FRAME DEPTH	DRIVER SIZE	*DRIVER TYPE*	DRIVE SHAFT DIA.	IDLER SIZE	IDLER TYPE	IDLER SHAFT DIA.	STANDARD CARRIER	STD. DRIVE	OTHER
700	Standard duty magnetic conveyor	12	6.625"	13 tooth	3.1" pd	1.1875"	13 tooth	3.1" pd	0.6875" hex	Magnets on 12" centers	Shaft	Standard duty and heavy duty magnets are available
711	Single strand drag	12	8.5"	12 tooth	3.854" pd	1.4375"	12 tooth	3.854" pd	1.1875"	1-1/2" UHMW cleats	Top	Available with standard or liquid tight bottom pan
716	Dual strand drag											
770	Slat conveyor	7	23"	8 tooth	15.68" pd	2.9375"	8 tooth	15.68"	2.1875"	5-7/8" x 1-1/2" x 7 ga.	Side	Slat conveyor

# Wire Mesh Conveyors

This light to medium-duty wire mesh conveyor is designed to handle special applications with a variety of deck options including rollers, longitudinal wear strips and herringbone wear strips.

**Model 800**

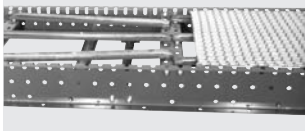

**Model 800**

Herringbone Wear Strip Deck:

- The Herringbone wear strips are made of stainless steel
- Ideal for water, high temperature and/or dirty and gritty applications
- The unique Herringbone deck pattern spreads the belt wear evenly across the belt

**Model 800**

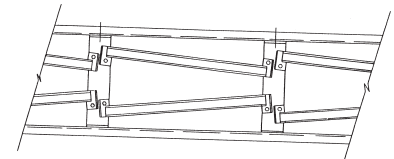

**Model 801**

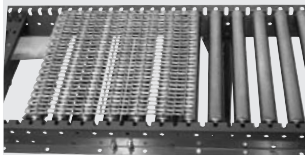

**Model 801**

Roller Bed Deck:

- Medium- to heavy-duty applications
- Rollers reduce friction between the wire mesh and deck optimizing drive horsepower

**Model 801**

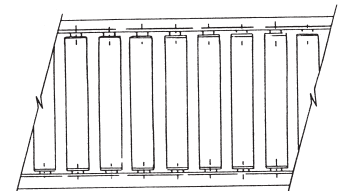

**Model 802**

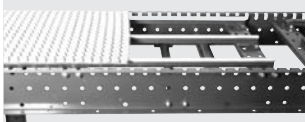

**Model 802**

High-density Plastic Wear Strip Deck:

- An all-around cost-effective performer
- Light- to medium-duty applications
- “Snap on, Snap off” wear strips are easy to replace

**Model 802**

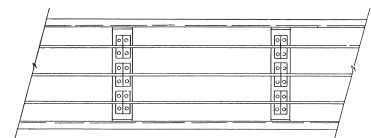



# Gravity Roller Conveyors

## Model 901, 910, 911, 920, 921 & 950 Gravity Roller Conveyors



## Series 900 (Gravity Roller Conveyor) Summary

MODEL	ROLLER DIAMETER	ROLLER TUBE GAUGE	HEX AXLE	FRAME DEPTH	FRAME GAUGE	ROLLER RATING
Model 901	1-3/8"	18	5/16	2-1/2" x 1"	12	100#
Model 910	2"	16	7/16	3-1/2" x 1-1/4"	10	240#
Model 911	2"	13	7/16	3-1/2" x 1-1/4"	10	280#
Model 920	2-1/2"	11	11/16	4 x 5.4#-channel frame		600#
Model 921	2-5/8"	7	11/16	4 x 5.4#-channel frame		650#
Model 950	3-1/2"	.300 wall pipe	1-1/16	6 x 8.2#-channel frame		2,000#

# Automatic Pallet Dispensers



### Pallet Dispenser Sequence of Operation

1. Pallets are loaded into the dispenser with the side clamps retracted.
2. Following loading, the side clamps are activated and grip the second pallet from the bottom.
3. The chain conveyor infeed then lowers releasing the bottom pallet.
4. Steps 2 & 3 are repeated until all pallets are emptied.

Unit includes all pneumatics up to piping. Controls are not included .  
(Note: there are 3 solenoid valves.)

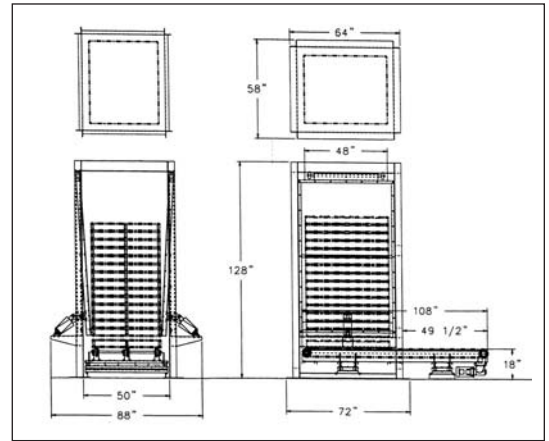

# Power Belt Curves



Powered belt curves are used in applications where positive orientation is critical in applications like baggage handling.

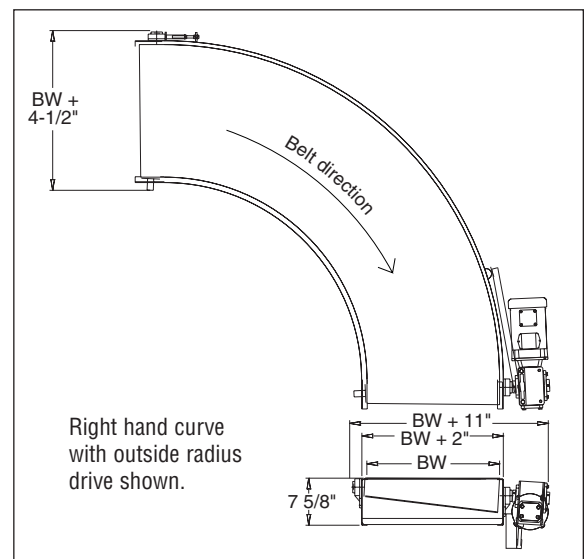

# Hinged Steel Belts Conveyors

**Model 715**



– Light duty, compact chip conveyor.

**Model 722 & 726**



– Light duty chip conveyor.

**Model 721 & 724**

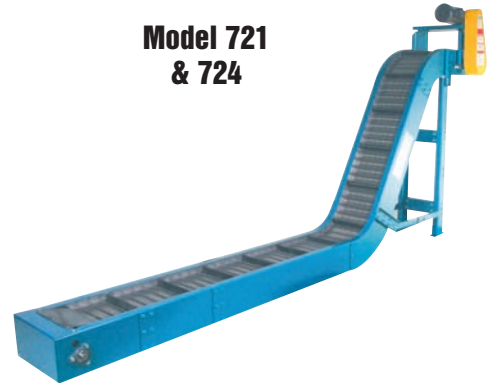

– Standard duty chip conveyor.

## Hinged Steel Belt Comparison Chart

**Hinged Steel Belt Conveyors – Chip and Scrap Hinged Steel Belt Conveyors** — Hinged Steel Belts are designed to carry hot & oily metal parts or scrap. When determining which hinged steel belt model fits your application, pay special attention to the unit's **frame depth and cleat height**. A deeper frame adds the strength needed for longer runs and heavier loads. Deeper frames also provide the room for taller cleats. A taller cleat will move more product than a shorter one. A taller cleat may also be required for steeper inclines (For example, a 1-1/2" high cleat will carry more load up a 60 degree incline than a 5/8" high cleat.) Other unit's lower profile frames are designed to fit into tight spaces.

MODEL	DESCRIPTION	FRAME GAUGE	FRAME DEPTH	DRIVER SIZE	DRIVER TYPE	DRIVE SHAFT DIA.	IDLER SIZE	IDLER TYPE	IDLER SHAFT DIA.	STANDARD CARRIER	STD. DRIVE	OTHER
715	Light duty – 1-1/2" pitch chip conveyor	14	4.125"	10 tooth	4.854 pd	1.1875"	1.375" OD	Hub	.75"	14ga aprons, 5/8" cleats on 12" centers	Top	Frame tapers from 4.125" @ infeed to 6-5/8" @ discharge
720 723	Medium duty chip conveyor Liquid tight M720	12	8.5"	6 tooth	5" pd	1.6875"	6 tooth	5" pd	1.1875"	12ga aprons, 1-3/8" cleats on 12-1/2" centers	Top	720 – Heavy shaft M721 723 – Heavy shaft, liquid tight M721
721 724	Standard duty scrap conveyor Liquid tight M721	12	8.5"	6 tooth	5" pd	1.4375"	6 tooth	5" pd	1.1875"	12ga aprons, 1-3/8" cleats on 12-1/2" centers	Top	Entire frame is 8-1/2" deep – Flat top cleats are 1-1/8" high
722 726	Light duty chip conveyor Liquid tight M722	12	6.625"	5 tooth	4.25" pd	1.1875"	5 tooth	4.25"	1.1875"	12ga aprons, 7/8" cleats on 12-1/2" centers	Top	Entire frame is 6-5/8" deep – Flat top cleats are 5/8" high
725	Low profile infeed chip conveyor	12	5.375"	5 tooth	4.25 pd	1.1875"	1.75" OD	Hub	.75"	12ga aprons, 7/8" cleats on 12-1/2" centers	Top	Frame tapers from 5-3/8" to 6-5/8" – Flat top cleats are 5/8" high
727	Tapered infeed cold header conveyor	12	6.625"	5 tooth	4.25 pd	1.1875"	5 tooth	4.25"	1.1875"	12ga aprons, 5/8" cleats on 12-1/2" centers	Top	Frame tapers from 6-5/8" to 4-1/8" back to 6-5/8"
751 750	4" pitch HSB Hvy drive shaft M751	10 10	15.25" 15.25"	6 tooth 6 tooth	8" pd 8" pd	1.9375" 2.9375"	6 tooth 6 tooth	8" pd 8" pd	1.6875" 1.9375"	7ga aprons, 2-3/8" cleats on 24" centers	Top	M750 Takeup at Infeed M751 Takeup at Drive
760	6" pitch hinged steel belt	Channel	23.25"	6 tooth	12" pd	3.4375"	6 tooth	12" pd	2.9375"	1/4" aprons, 4" cleats on 48" centers	Top	Heavy duty hinged steel belt applications

**Model 725**

– Low profile infeed chip conveyor.

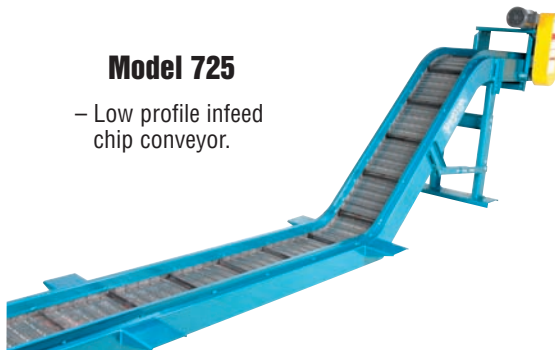

**Model 727**

– Tapered infeed cold header conveyor.



**Model 751 & 750**

– Heavy duty chip & scrap conveyor.



**Model 760**

– Heavy duty scrap and chip conveyor.

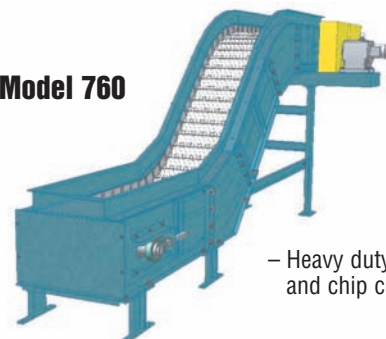



# Hinged Steel Belt Summary

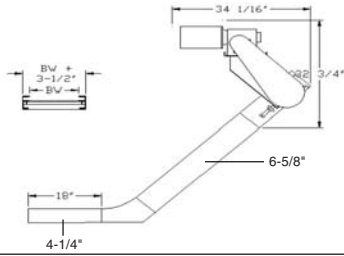

## Model 715

### Application Summary

- Very low profile
- Very small and lightweight applications

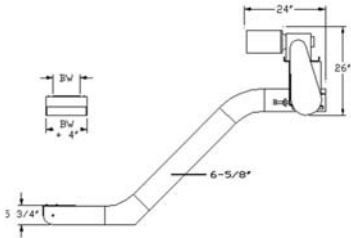

## Model 725

### Application Summary

- Low profile
- Tight fit lightweight applications

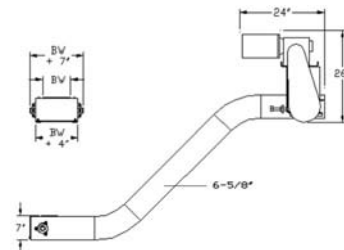

## Model 722 & Model 726

### Application Summary

- Tight fit applications
- Small scrap conveyor (scrap less than 1/4" x 1/4" conveyor)

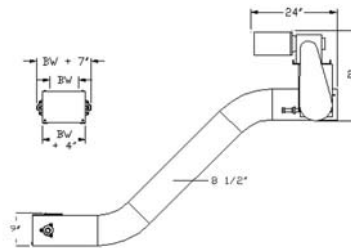

## Model 721 & Model 724

### Application Summary

- The industry's most economical and dependable scrap conveyor

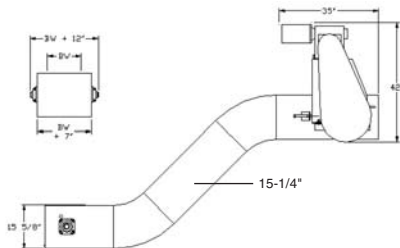

## Model 751

### Application Summary

- Heavier scrap with high volumes

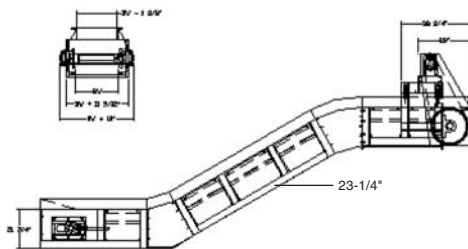

## Model 760

### Application Summary

- Heavy scrap and high volumes

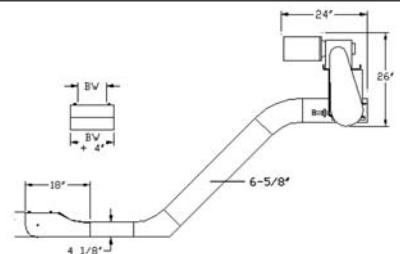

## Model 727

### Application Summary

- Cold header conveyor
- Designed to fit into an existing machine



# Unconditional Shipment Guarantee

New London Engineering guarantees  
that all UPTime Express™ orders  
placed by 2:00 p.m. Central Time  
will ship by our designated carrier on the  
date promised, or we pay the freight.



MODEL	721	722	200	210	220	500	ToughTrak
SHIPMENT	3-5 Days	3-5 Days	24 Hours	24 Hours	24 Hours	24 Hours	48 Hours
WIDTHS	6, 8, 12, 18, 24"	6, 8, 12, 18, 24"	4, 6, 8, 10, 12, 18, 24, 30"	8, 12, 18, 24, 30"	12, 18, 24, 30, *36" <i>*36" – 20' max.</i>	4, 6, 8, 12, 18, 24"	4, 6, 8, 12, 18, 24"
LENGTHS	20' maximum Degree Curves 30, 45 & 60	20' maximum Degree Curves 30, 45 & 60	5' – 40'	5' – 100'	5' – 100'	4' – 12'	2' – 10' End Drives Only
SPEEDS	Fixed 30, 45 & 60 FPM DC Variable - 1.5-30, 2.25-45 & 3-60 FPM	Fixed 30, 45 & 60 FPM DC Variable - 1.5-3.0, 2.25-45, 3-60 FPM	Fixed 30, 60, 90 & 120 FPM DC Variable - 1.5-30, 3-60, 4.5-90 & 6-120 FPM	Fixed 30, 60, 90 & 120 FPM DC Variable - 1.5-30, 3-60, 4.5-90 & 6-120 FPM	Fixed 30, 60, 90 & 120 FPM DC Variable - 1.5-30, 3-60, 4.5-90 & 6-120 FPM	Fixed 30, 60 & 90 FPM DC Variable - 1.5-30, 3-60, 4.5-90 & 6-120 FPM	<b>*150–1 Phase</b> 1/6 HP @ 28, 57 <b>*150–3 Phase</b> 1/4 HP @ 29, 58 <b>*150–90V</b> 1/6 HP @ 30, 59 <b>*250–1 &amp; 3 Phase</b> 1/3 HP @ 30, 60 <b>*250–90V</b> 1/4 @ 30,60 1/2 @ 30,60 <b>*150 &amp; 250</b> DC Variable - 1.5-30, 30-60 FPM
MOTORS	1 & 3 phase 1/2, 3/4, 1 & 1-1/2 HP 90 V DC - 1/2 & 3/4 HP	1 & 3 phase 1/2, 3/4, 1 & 1-1/2 HP 90 V DC - 1/2 & 3/4 HP	1 & 3 phase 1/3, 1/2, 1* & 3/4 HP <b>*1 HP in all but 30 FPM</b> 90 V DC - 1/4, 1/2 & 3/4 HP	1 & 3 phase 1/3, 1/2, 1* & 3/4 HP <b>*1 HP in all but 30 FPM</b> 90 V DC - 1/4, 1/2 & 3/4 HP	1 & 3 phase 1/3, 1/2, 1* & 3/4 HP <b>*1 HP in all but 30 FPM</b> 90 V DC - 1/4, 1/2 & 3/4 HP	1 & 3 phase 1/3, 1/2, 1* & 3/4 HP <b>*1 HP in all but 30 FPM</b> 90 V DC - 1/4, 1/2 & 3/4 HP	150 – Shaft Mt Right Angle (#15) 250 – Bottom Mt. Right Angle (#23)
DRIVES	Top mount & side mount R or L side	Top mount & side mount R or L side	Bottom mount – R or L side or center drive and take-up	Bottom mount – R or L side or center drive and take-up	Bottom mount – R or L side or center drive and take-up	Top mount – R or L side	150 – Shaft Mt Right Angle (#15) 250 – Bottom Mt. Right Angle (#23)
BELTS	Conventional or flat top (plain, pimped or perforated)	Conventional or flat top (plain, pimped or perforated)	Black PVC 120 (#65) 4", 6", 8", 10", 12", 18", 24", 30" Blk Rubber Rough Top (#47) 8", 12", 18", 24", 30" 2 Ply Green Urethane (#249) 4", 6", 8", 12", 18", 24"	Black PVC 120 (#65) 8", 12", 18", 24", 30" Blk Rubber Rough Top (#47) 8", 12", 18", 24", 30" 2 Ply Green Urethane (#249) 8", 12", 18", 24"	Black PVC 120 (#65) 12", 18", 24", 30", 36" Blk Rubber Rough Top (#47) 12", 18", 24", 30" 2 Ply Green Urethane (#249) 12", 18", 24"	Black PVC 120 with 1-1/2" high cleats on 12" centers	Black PVC 70 (#251) 4", 6", 8", 12", 18", 24"  2 Ply Green Urethane (#249) 4", 6", 8", 10", 12", 18", 24"
SUPPORTS	0-73" BOF	0-73" BOF	TOB minimum 20" maximum 48"	TOB minimum 20" maximum 48"	TOB minimum 20" maximum 48"	TOB minimum 20" maximum 48"	TOB minimum 20" maximum 48"
CASTERS	4 & 6" diameter Rigid & Swivel	4 & 6" diameter Rigid & Swivel	4 & 6" diameter Rigid & Swivel	4 & 6" diameter Rigid & Swivel	4 & 6" diameter Rigid & Swivel	4 & 6" diameter Rigid & Swivel	3-1/4" diameter Rigid & Swivel
SIDERAILS	Vertical Rails 2, 3-1/2 & 6"	Vertical Rails 2, 3-1/2 & 6"	Vertical Rails 1-1/2, 3-1/2 & 6"	Vertical Rails 1-1/2, 3-1/2 & 6"	Vertical Rails 1-1/2, 3-1/2 & 6"	Vertical Rails 3-1/2 & 6"	1" & 2" Vertical 1" & 2" Flared
OTHER OPTIONS	Impact bars, standard cleats, radial sidewings, outside sidebars and bolt-on	Impact bars, standard cleats, radial sidewings, outside sidebars and bolt-on	bottom pan	bottom pan		Bolt-on bottom pan & standard infeed hopper	M150 Gearmotors – 1.5-30 FPM – 1/12 HP (#100581A2) (#100581A3) – 30-60 FPM – 1/6 HP (#100582A2) (#100582A3)
CONTROLS	Manual Starter @ 120/1/60 w/O.L. Protection and Start/Stop (#1091202)	Manual Snap Switch @ 120/1/60 w/O.L. Protection (#10912.15)	Magnetic Non-reversing Starter @ 240 or 480/3/60 w/O.L. Protection with Start/Stop Push Button 240V – (#100382) 460V – (#100383)	Magnetic Reversing Starter @ 240 or 480/3/60 w/O.L. Protection with Start/Stop/Reverse Push Buttons 240V – (#100386) 460V – (#100387)			

Electrical controls on UPTIME Express™ equipment orders are shipped loose. Mounting and wiring of electric controls require an additional 24 hours.



# CUSTOM AND STANDARD CONVEYORS

We are a full line conveyor supplier specializing in engineering high quality, quick delivery conveyors.

- Accumulation Conveyors
- Belt Driven Live Roller Conveyors
- Bulk Material Handling Conveyors
- Cleated Belt Parts Conveyors
- Chain Driven Live Roller Conveyors
- Chain Transfers
- Drag Conveyors
- Floor-to-Floor Conveyors
- Gravity Roller
- Magnetic Conveyors
- Pallet Dispensers
- Power Roller Conveyors
- PlastiTrak - A full line of plastic belt conveyors
- Quick Start Electrical Controls
- Slat Conveyors
- Slider Bed Conveyors
- Specialty Conveyors
- SteelTrak - Hinged Steel Belt Conveyors
- ToughTrak - Tough and durable thin line conveyors
- Turntables
- UpTime Express - 24 hour shipments
- V-Belt Conveyors
- Wire Mesh Conveyors



## REPLACEMENT PARTS

For easy part identification,  
go to [NLECO.com](http://NLECO.com) and  
click on Replacement Parts

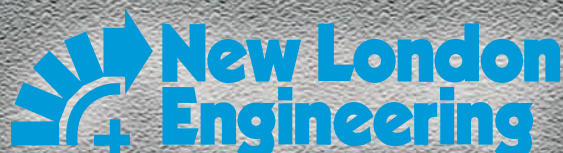

Brochure #GC05-07

