

# ROBOTIC AUTOMATION SOLUTIONS

Powered by  
**24  
VOLT**

## Your Robot

NorthAmCon, LLC offers 24V power driven technologies to meet an endless range of Robotic & Automation solutions with both Motor Driven Roller (MDR) and Flat Motor Driven Roller (FMDR) technology.

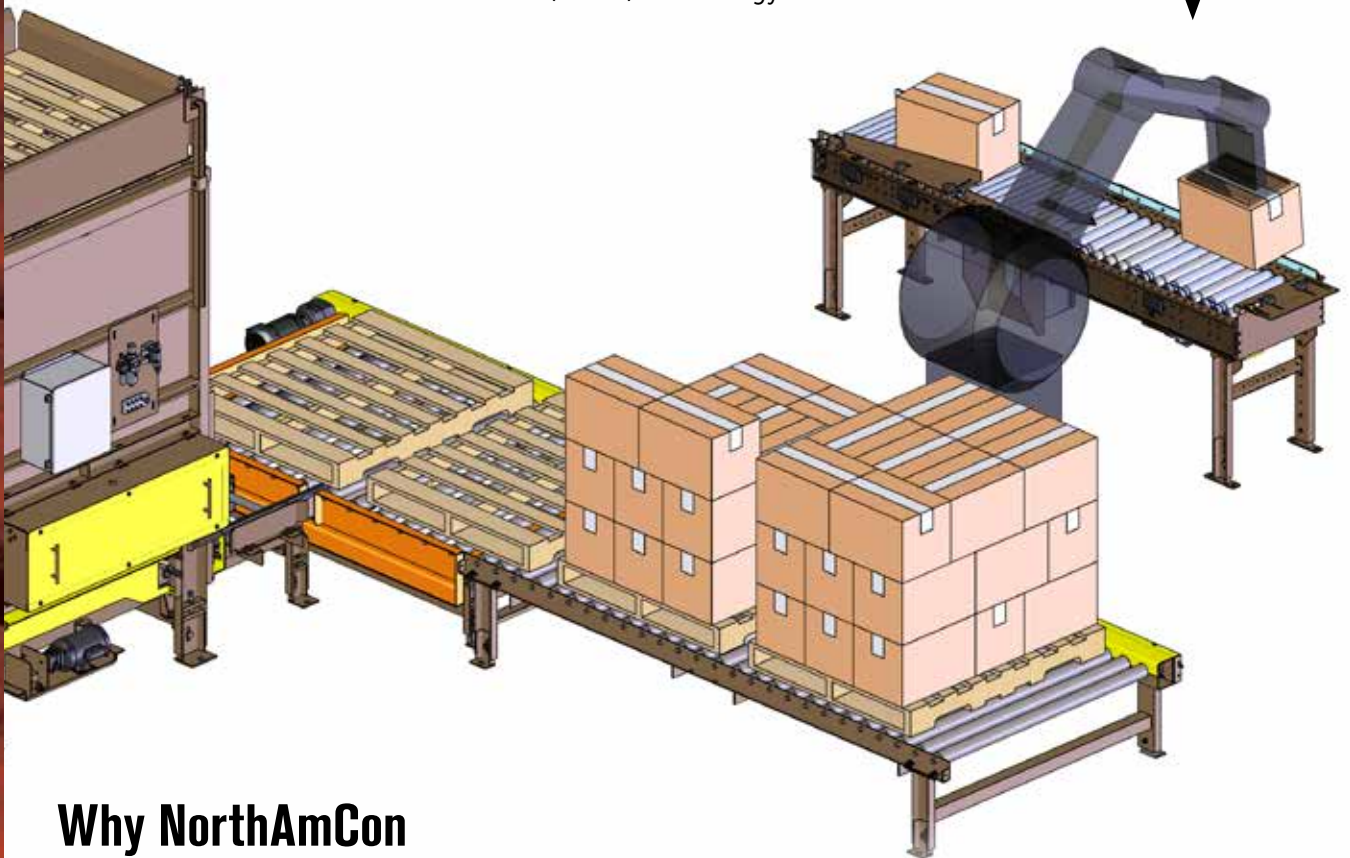

## Why NorthAmCon

- Built to application needs including customization for end of arm tooling in pick zones
- Paint to match your supplied equipment
- Your preferred brand components
- Documentation and drawings with your label and title block
- Multiple drive methods including o-ring, poly-ribbed belt, and chain
- Roller driven by Motor Driven Roller (MDR) or Flat Motor Driven Roller (FMDR)

Modern  
Conveyor  
Utilizing  
24V Drive  
Technology

# Robotic Automation Solutions

---

Our Equipment Integrates with Your Robotic & Automation Equipment

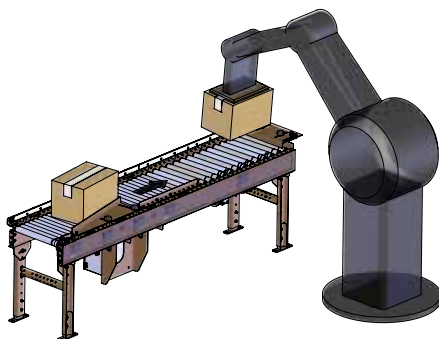

## Packaging

Conveyors to interface with your robotic packaging machinery including case formers, erectors, packers, fillers, taping and gluing systems.

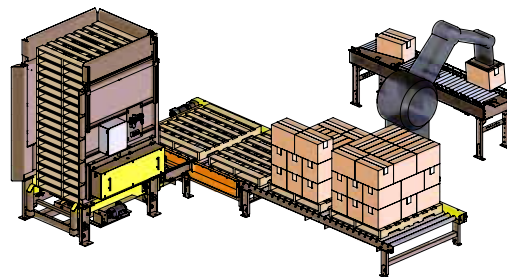

## End of Line Automation

Conveyors to interface with your robotic palletizing/depalletizing machinery including pallet wrappers and strappers.

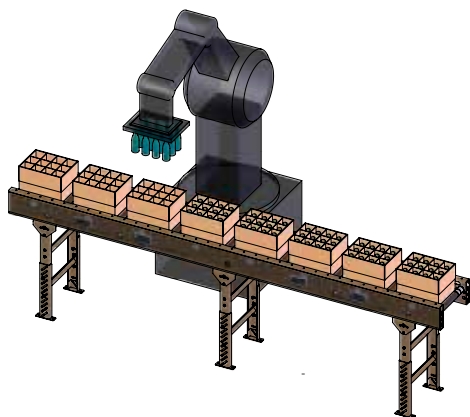

## Material Handling

Conveyors to interface with your robotic material handling equipment including stackers, destackers, dispensers, pick and place.

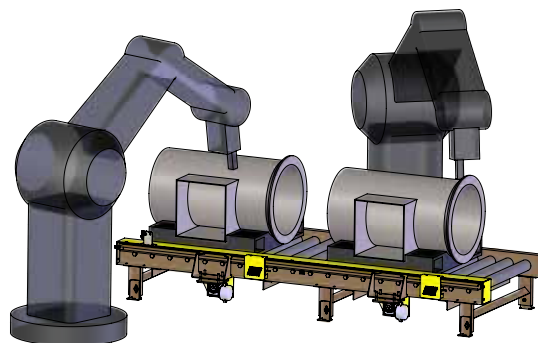

## Automation Assembly

Conveyors to interface with your robotic automated assembly equipment including welding and painting.

## About Us

NorthAmCon, LLC manufactures a full line of standard and build-to-order 24V powered conveyors and other material handling equipment ideal for the manufacturing, packaging, distribution, logistics, and robotics & automation industries. NorthAmCon specializes in meeting the customer's need with the agility and flexibility of a custom fabricator combined with the capabilities of a leading manufacturer to deliver solutions that meet the application requirements.