



- **Part Number:**1910
- **Part Number Title:** Occupational Safety and Health Standards
- **Subpart:** 1910 Subpart D
- **Subpart Title:** Walking-Working Surfaces
- **Standard Number:** [1910.23](#)
- **Title:** Ladders.
- This regulation governs ladders that are fixed in place and used regularly in commercial environments. It discusses the types of materials to be used, the structural load the ladders must hold, and the setting and materials into which they can be attached.

1910.23(a)

Application. The employer must ensure that each ladder used meets the requirements of this section. This section covers all ladders, except when the ladder is:

[1910.23\(a\)\(1\)](#)

Used in emergency operations such as firefighting, rescue, and tactical law enforcement operations, or training for these operations; or

[1910.23\(a\)\(2\)](#)

Designed into or is an integral part of machines or equipment.

[1910.23\(b\)](#)

General requirements for all ladders. The employer must ensure:

1910.23(b)(1)

Ladder rungs, steps, and cleats are parallel, level, and uniformly spaced when the ladder is in position for use;

[1910.23\(b\)\(2\)](#)

Ladder rungs, steps, and cleats are spaced not less than 10 inches (25 cm) and not more than 14 inches (36 cm) apart, as measured between the centerlines of the rungs, cleats, and steps, except that:

1910.23(b)(2)(i)

Ladder rungs and steps in elevator shafts must be spaced not less than 6 inches (15 cm) apart and not more than 16.5 inches (42 cm) apart, as measured along the ladder side rails; and

1910.23(b)(2)(ii)

Fixed ladder rungs and steps on telecommunication towers must be spaced not more than 18 inches (46 cm) apart, measured between the centerlines of the rungs or steps;

1910.23(b)(3)

Steps on stepstools are spaced not less than 8 inches (20 cm) apart and not more than 12 inches (30 cm) apart, as measured between the centerlines of the steps;

1910.23(b)(4)

Ladder rungs, steps, and cleats have a minimum clear width of 11.5 inches (29 cm) on portable ladders and 16 inches (41 cm) (measured before installation of ladder safety systems) for fixed ladders, except that:

1910.23(b)(4)(i)

The minimum clear width does not apply to ladders with narrow rungs that are not designed to be stepped on, such as those located on the tapered end of orchard ladders and similar ladders;

1910.23(b)(4)(ii)

Rungs and steps of manhole entry ladders that are supported by the manhole opening must have a minimum clear width of 9 inches (23 cm);

1910.23(b)(4)(iii)

Rungs and steps on rolling ladders used in telecommunication centers must have a minimum clear width of 8 inches (20 cm); and

1910.23(b)(4)(iv)

Stepstools have a minimum clear width of 10.5 inches (26.7 cm);

1910.23(b)(5)

Wooden ladders are not coated with any material that may obscure structural defects;

1910.23(b)(6)

Metal ladders are made with corrosion-resistant material or protected against corrosion;

1910.23(b)(7)

Ladder surfaces are free of puncture and laceration hazards;

1910.23(b)(8)

Ladders are used only for the purposes for which they were designed;

1910.23(b)(9)

Ladders are inspected before initial use in each work shift, and more frequently as necessary, to identify any visible defects that could cause employee injury;

[1910.23\(b\)\(10\)](#)

Any ladder with structural or other defects is immediately tagged "Dangerous: Do Not Use" or with similar language in accordance with § 1910.145 and removed from service until repaired in accordance with § 1910.22(d), or replaced;

1910.23(b)(11)

Each employee faces the ladder when climbing up or down it;

[1910.23\(b\)\(12\)](#)

Each employee uses at least one hand to grasp the ladder when climbing up and down it; and

[1910.23\(b\)\(13\)](#)

No employee carries any object or load that could cause the employee to lose balance and fall while climbing up or down the ladder.

[1910.23\(c\)](#)

Portable ladders. The employer must ensure:

[1910.23\(c\)\(1\)](#)

Rungs and steps of portable metal ladders are corrugated, knurled, dimpled, coated with skid-resistant material, or otherwise treated to minimize the possibility of slipping;

[1910.23\(c\)\(2\)](#)

Each stepladder or combination ladder used in a stepladder mode is equipped with a metal spreader or locking device that securely holds the front and back sections in an open position while the ladder is in use;

[1910.23\(c\)\(3\)](#)

Ladders are not loaded beyond the maximum intended load;

Note to paragraph (c)(3):

The maximum intended load, as defined in § 1910.21(b), includes the total load

(weight and force) of the employee and all tools, equipment, and materials being carried.

[1910.23\(c\)\(4\)](#)

Ladders are used only on stable and level surfaces unless they are secured or stabilized to prevent accidental displacement;

1910.23(c)(5)

No portable single rail ladders are used;

1910.23(c)(6)

No ladder is moved, shifted, or extended while an employee is on it;

1910.23(c)(7)

Ladders placed in locations such as passageways, doorways, or driveways where they can be displaced by other activities or traffic:

1910.23(c)(7)(i)

Are secured to prevent accidental displacement; or

1910.23(c)(7)(ii)

Are guarded by a temporary barricade, such as a row of traffic cones or caution tape, to keep the activities or traffic away from the ladder;

1910.23(c)(8)

The cap (if equipped) and top step of a stepladder are not used as steps;

[1910.23\(c\)\(9\)](#)

Portable ladders used on slippery surfaces are secured and stabilized;

1910.23(c)(10)

The top of a non-self-supporting ladder is placed so that both side rails are supported, unless the ladder is equipped with a single support attachment;

1910.23(c)(11)

Portable ladders used to gain access to an upper landing surface have side rails that extend at least 3 feet (0.9 m) above the upper landing surface (see Figure D-1 of this section);

1910.23(c)(12)

Ladders and ladder sections are not tied or fastened together to provide added length unless they are specifically designed for such use;

1910.23(c)(13)

Ladders are not placed on boxes, barrels, or other unstable bases to obtain additional height.

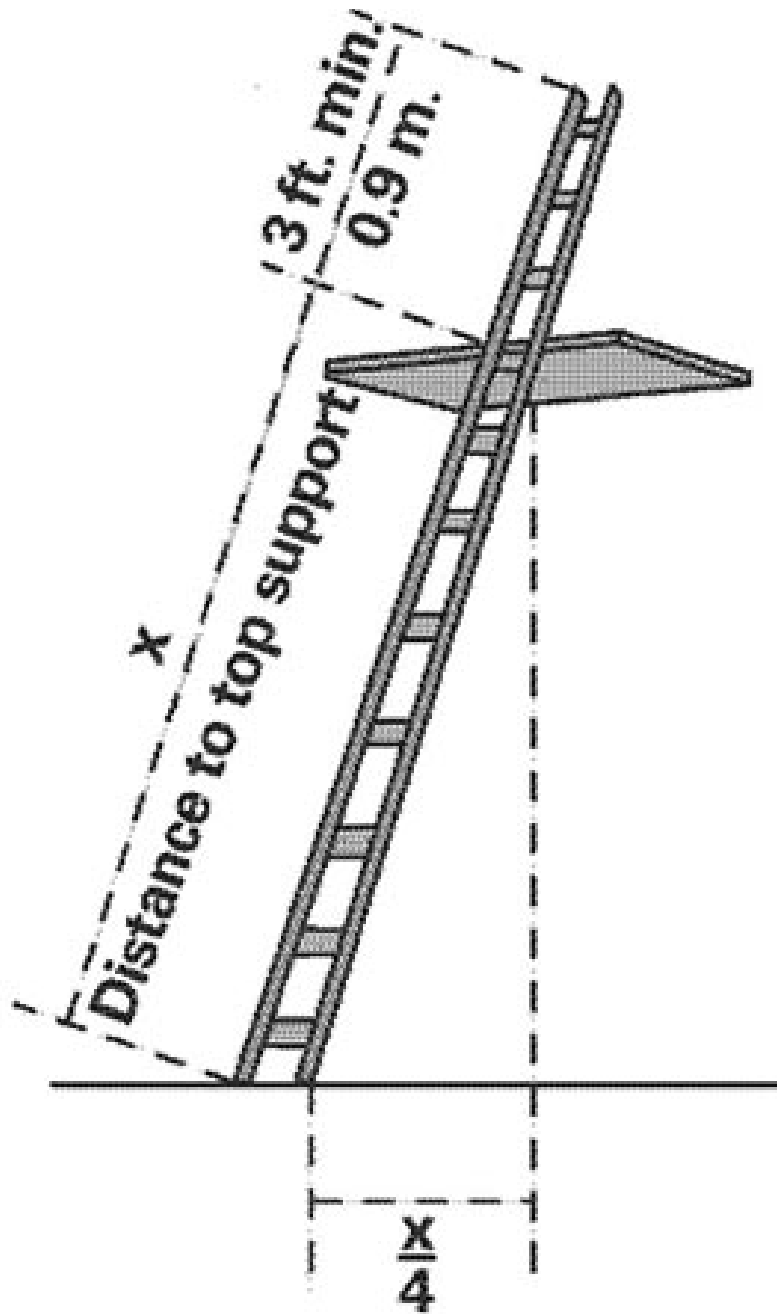

Figure D-1 -- Portable Ladder Set-up

[1910.23\(d\)](#)

Fixed ladders. The employer must ensure:

[1910.23\(d\)\(1\)](#)

Fixed ladders are capable of supporting their maximum intended load;

1910.23(d)(2)

The minimum perpendicular distance from the centerline of the steps or rungs, or grab bars, or both, to the nearest permanent object in back of the ladder is 7 inches (18 cm), except for elevator pit ladders, which have a minimum perpendicular distance of 4.5 inches (11 cm);

1910.23(d)(3)

Grab bars do not protrude on the climbing side beyond the rungs of the ladder that they serve;

[1910.23\(d\)\(4\)](#)

The side rails of through or side-step ladders extend at least 42 inches (1.1 m) above the top of the access level or landing platform served by the ladder. For parapet ladders, the access level is:

[1910.23\(d\)\(4\)\(i\)](#)

The roof, if the parapet is cut to permit passage through the parapet; or

[1910.23\(d\)\(4\)\(ii\)](#)

The top of the parapet, if the parapet is continuous;

1910.23(d)(5)

For through ladders, the steps or rungs are omitted from the extensions, and the side rails are flared to provide not less than 24 inches (61cm) and not more than 30 inches (76 cm) of clearance. When a ladder safety system is provided, the maximum clearance between side rails of the extension must not exceed 36 inches (91 cm);

1910.23(d)(6)

For side-step ladders, the side rails, rungs, and steps must be continuous in the extension (see Figure D-2 of this section);

1910.23(d)(7)

Grab bars extend 42 inches (1.1 m) above the access level or landing platforms served by the ladder;

1910.23(d)(8)

The minimum size (cross-section) of grab bars is the same size as the rungs of the ladder.

1910.23(d)(9)

When a fixed ladder terminates at a hatch (see Figure D-3 of this section), the hatch cover:

1910.23(d)(9)(i)

Opens with sufficient clearance to provide easy access to or from the ladder; and

1910.23(d)(9)(ii)

Opens at least 70 degrees from horizontal if the hatch is counterbalanced;

1910.23(d)(10)

Individual-rung ladders are constructed to prevent the employee's feet from sliding off the ends of the rungs (see Figure D-4 of this section);

1910.23(d)(11)

Fixed ladders having a pitch greater than 90 degrees from the horizontal are not used;

1910.23(d)(12)

The step-across distance from the centerline of the rungs or steps is:

1910.23(d)(12)(i)

For through ladders, not less than 7 inches (18 cm) and not more than 12 inches (30 cm) to the nearest edge of the structure, building, or equipment accessed from the ladders;

1910.23(d)(12)(ii)

For side-step ladders, not less than 15 inches (38 cm) and not more than 20 inches (51 cm) to the access points of the platform edge;

1910.23(d)(13)

Fixed ladders that do not have cages or wells have:

1910.23(d)(13)(i)

A clear width of at least 15 inches (38 cm) on each side of the ladder centerline to the nearest permanent object; and

1910.23(d)(13)(ii)

A minimum perpendicular distance of 30 inches (76 cm) from the centerline of the steps or rungs to the nearest object on the climbing side. When unavoidable obstructions are encountered, the minimum clearance at the obstruction may be

reduced to 24 inches (61 cm), provided deflector plates are installed (see Figure D-5 of this section).

Note to paragraph (d):

Section 1910.28 establishes the employer's duty to provide fall protection for employees on fixed ladders, and § 1910.29 specifies the criteria for fall protection systems for fixed ladders.

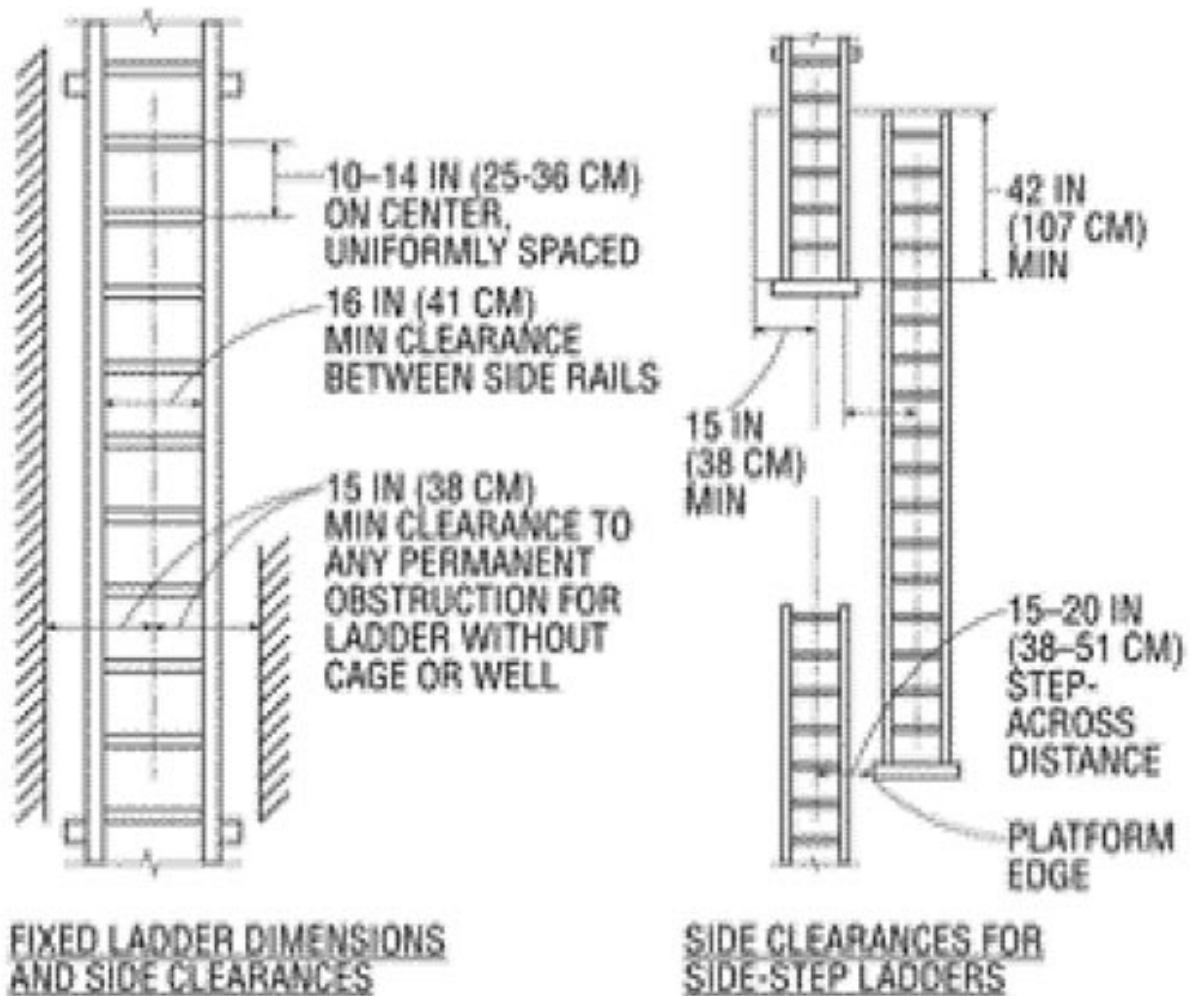

Figure D-2 -- Side-Step Fixed Ladder Sections

Slide-Step Fixed Ladder Sections. Two diagrams depicted. First one is for Fixed Ladder Dimensions and Side Clearances. 10-14 IN (25-36 CM) On Center. Uniformly spaced. 16 IN (41 CM) Min Clearance between side rails. 15 IN (38 CM) Min clearance to any permanent obstruction for ladder without cage or well. Second one is for Side Clearances for Side-step

ladders. 15-20 IN (30-51 CM) Step-Across Distance to Platform edge. 42 IN (107 CM) Min. 15 IN (38 CM) Min.

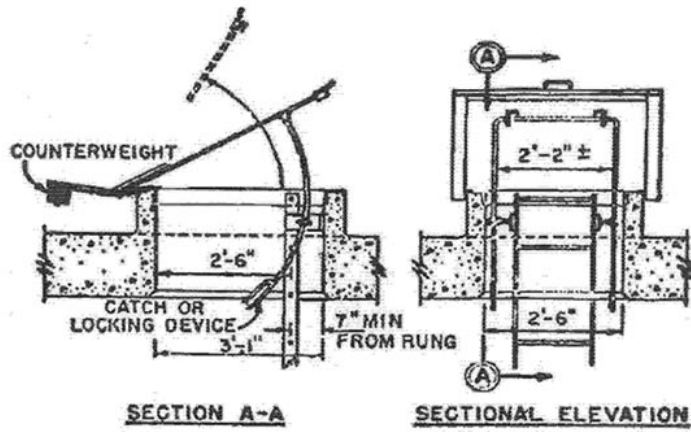

Figure D-3 – Example of Counterbalanced Hatch Cover at Roof

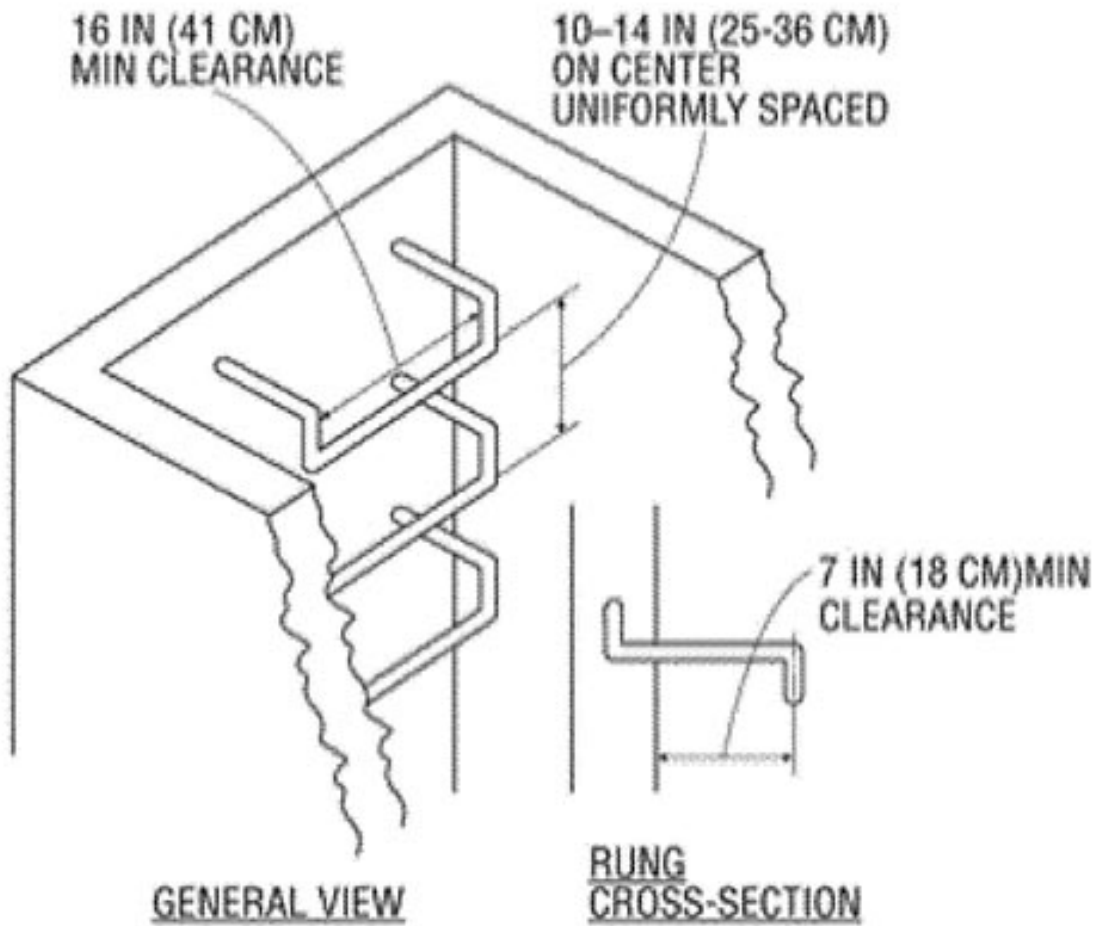

Figure D-4 -- Individual Rung Ladder

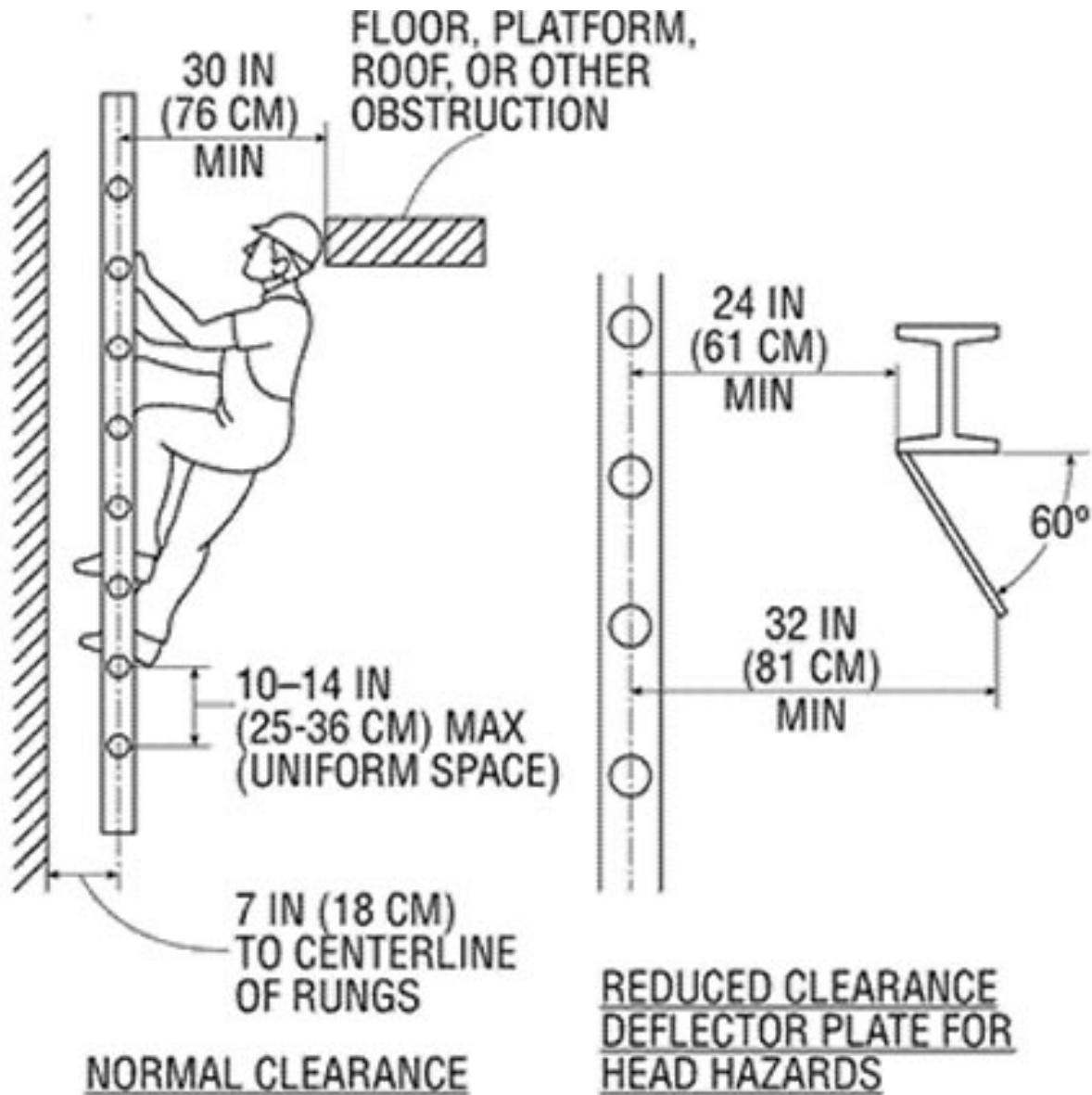

Figure D-5 -- Fixed Ladder Clearances

[1910.23\(e\)](#)

Mobile ladder stands and mobile ladder stand platforms -

[1910.23\(e\)\(1\)](#)

General requirements. The employer must ensure:

1910.23(e)(1)(i)

Mobile ladder stands and platforms have a step width of at least 16 inches (41 cm);

1910.23(e)(1)(ii)

The steps and platforms of mobile ladder stands and platforms are slip resistant. Slip-resistant surfaces must be either an integral part of the design and construction of the mobile ladder stand and platform, or provided as a secondary process or operation, such as dimpling, knurling, shotblasting, coating, spraying, or applying durable slip-resistant tapes;

1910.23(e)(1)(iii)

Mobile ladder stands and platforms are capable of supporting at least four times their maximum intended load;

1910.23(e)(1)(iv)

Wheels or casters under load are capable of supporting their proportional share of four times the maximum intended load, plus their proportional share of the unit's weight;

1910.23(e)(1)(v)

Unless otherwise specified in this section, mobile ladder stands and platforms with a top step height of 4 feet (1.2 m) or above have handrails with a vertical height of 29.5 inches (75 cm) to 37 inches (94 cm), measured from the front edge of a step. Removable gates or non-rigid members, such as chains, may be used instead of handrails in special-use applications;

1910.23(e)(1)(vi)

The maximum work-surface height of mobile ladder stands and platforms does not exceed four times the shortest base dimension, without additional support. For greater heights, outriggers, counterweights, or comparable means that stabilize the mobile ladder stands and platforms and prevent overturning must be used;

1910.23(e)(1)(vii)

Mobile ladder stands and platforms that have wheels or casters are equipped with a system to impede horizontal movement when an employee is on the stand or platform; and

1910.23(e)(1)(viii)

No mobile ladder stand or platform moves when an employee is on it.

[1910.23\(e\)\(2\)](#)

Design requirements for mobile ladder stands. The employer must ensure:

1910.23(e)(2)(i)

Steps are uniformly spaced and arranged, with a rise of not more than 10 inches (25 cm) and a depth of not less than 7 inches (18 cm). The slope of the step stringer to which the steps are attached must not be more than 60 degrees, measured from the horizontal;

1910.23(e)(2)(ii)

Mobile ladder stands with a top step height above 10 feet (3 m) have the top step protected on three sides by a handrail with a vertical height of at least 36 inches (91 cm); and top steps that are 20 inches (51 cm) or more, front to back, have a midrail and toeboard. Removable gates or non-rigid members, such as chains, may be used instead of handrails in special-use applications; and

1910.23(e)(2)(iii)

The standing area of mobile ladder stands is within the base frame.

[1910.23\(e\)\(3\)](#)

Design requirements for mobile ladder stand platforms. The employer must ensure:

1910.23(e)(3)(i)

Steps of mobile ladder stand platforms meet the requirements of paragraph (e)(2)(i) of this section. When the employer demonstrates that the requirement is not feasible, steeper slopes or vertical rung ladders may be used, provided the units are stabilized to prevent overturning;

[1910.23\(e\)\(3\)\(ii\)](#)

Mobile ladder stand platforms with a platform height of 4 to 10 feet (1.2 m to 3 m) have, in the platform area, handrails with a vertical height of at least 36 inches (91 cm) and midrails; and

1910.23(e)(3)(iii)

All ladder stand platforms with a platform height above 10 feet (3 m) have guardrails and toeboards on the exposed sides and ends of the platform.

[1910.23\(e\)\(3\)\(iv\)](#)

Removable gates or non-rigid members, such as chains, may be used on mobile ladder stand platforms instead of handrails and guardrails in special-use applications.