

TEKZONE WORKSTATION HUTCH

TEKZONE HUTCH



Creates a secure, organized and personalized workspace.



Easy and tool-free reconfiguration allows your workstation to evolve in line with your needs.

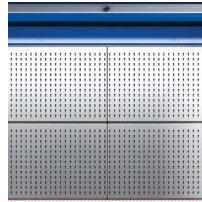

Spacious and well-lit workspace.



Door opens and closes easily, smoothly and securely.



INDEX	PAGE(S)
TekZone Workstation Hutch	172
Preconfigured Models . . .	173-174
Step by Step	175-177
Accessories	178-179

TEKZONE WORKSTATION HUTCH

With the TekZone workstation hutch, you can create a personalized and organized workspace.

The work area it provides is spacious and well lit. Each TekZone Hutch is equipped with an LED light with motion sensor so the workspace lights up as soon as you open the door.

A wide range of accessories helps you to stay tidy by freeing up the work surface, while keeping your essential tools close at hand.

The ingenious door mechanism allows you to open and close the hutch easily, smoothly and securely. With the full-width handle, you can open the door with any hand position. The door is fitted with a lock to protect the contents of the hutch.

The TekZone Hutch installs on heavy-duty cabinets, Rousseau workstations and most other workstations on the market. Treat yourself to a unique solution!

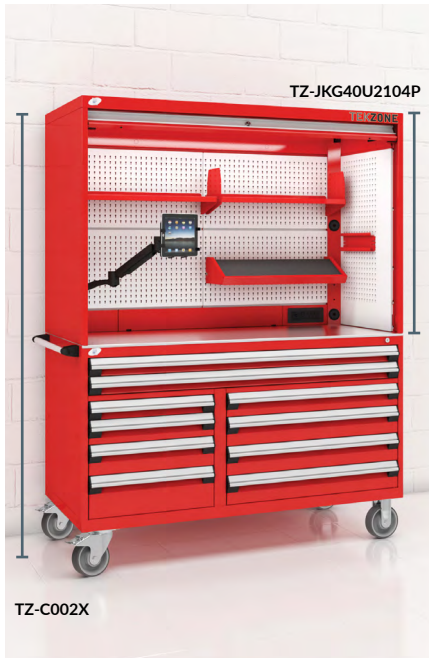

TEKZONE MOBILE WORKCENTER

PRODUCT NO.	W×D×H
TZ-C002X*	60" × 27" × 77½"
1 Multi-drawer mobile cabinet	R5GKG-3018
1 Thin stainless steel top	RH11-6027
1 Hutch with painted steel utility panels, LED light with motion sensor, 1 painted steel power feed panel with 3 power outlets (12A) and 2 USB ports (1 A, 1 C)	TZ-JKG40U2002P
1 Battery charger shelf	RH54-26
1 Electronic tablet arm	WM06-62-01
2 Half width shelves	RH60-2412
2 Partial dividers	SH52-1206
1 Plastic bin rail	WM9C-12

60"W HUTCH

PRODUCT NO.	W×D×H
TZ-JKG40U2104P	60" × 27" × 40"
1 Hutch with painted steel utility panels, LED light with motion sensor, 1 painted steel power feed panel with 3 power outlets (12A) and 2 USB ports (1 A, 1 C)	TZ-JKG40U2002P
1 Battery charger shelf	RH54-26
1 Electronic tablet arm	WM06-62-01
2 Half width shelves	RH60-2412
2 Partial dividers	SH52-1206
1 Plastic bin rail	WM9C-12

NOTE: *The hutch is factory assembled on the cabinet with this model.



TEKZONE WORKCENTER

PRODUCT NO.	W×D×H
TZ-C040S*	48" × 30" × 76"
1 Multi-drawer cabinet with 4"H base	R5KHG-3030S
1 Pre-punched stainless steel top	RC35-4830-02
1 Hutch with stainless steel utility panels, LED light with motion sensor, 1 stainless steel power feed panel with 3 power outlets (12A), 2 USB ports (1 A, 1 C), knockout and perforation	TZ-JHG40U3002S
1 Electronic tablet arm	WM06-62-01
2 Half width shelves	RH60-2412
3 Partial dividers	SH52-1206
1 Can holder	WM9D-12
1 Wire spool and roll holders	WM9P-1201

48"W HUTCH

PRODUCT NO.	W×D×H
TZ-JHG40U3104S	48" × 27" × 40"
1 Hutch with stainless steel utility panels, LED light with motion sensor, 1 stainless steel power feed panel with 3 power outlets (12A), 2 USB ports (1 A, 1 C), knockout and perforation	TZ-JHG40U3002S
1 Electronic tablet arm	WM06-62-01
2 Half width shelves	RH60-2412
3 Partial dividers	SH52-1206
1 Can holder	WM9D-12
1 Wire spool and roll holder	WM9P-1201

NOTE: *The hutch is factory assembled on the cabinet with this model.

PRECONFIGURED MODELS



TEKZONE CONSULTATION STATION

PRODUCT NO.	W×D×H
TZ-C010P*	36"×27"×80"
1 Heavy-duty cabinet with 4" base	R5AEE-3414P
1 Pre-punched painted steel top	RC37-3627-02
1 Hutch with painted steel utility panels, LED light with motion sensor, 1 painted steel power feed panel with 3 power outlets (12A) and 2 USB ports (1 A, 1 C)	TZ-JEE40X2002P
1 Monitor mount	RH52-15
1 Keyboard tray	RH53-25
1 Can holder	WM9D-09

36"W HUTCH

PRODUCT NO.	W×D×H
TZ-JEE40X2102P	36"×24"×40"
1 Hutch with painted steel utility panels, LED light with motion sensor, 1 painted steel power feed panel with 3 power outlets (12A) and 2 USB ports (1 A, 1 C)	TZ-JEE40X2002P
1 Monitor mount	RH52-15
1 Keyboard tray	RH53-25
1 Can holder	WM9D-09

NOTE: *The hutch is factory assembled on the cabinet with this model.



TEKZONE WORKSTATION

PRODUCT NO.	W×D×H
TZ-C018PW	60"×30"×74"
1 Desk with closed legs and pre-punched wood top, 1 power outlet (12A) and 2 USB ports (1 A, 1 C)	WSA2090
1 Hutch with painted steel utility panels, LED light with motion sensor, 1 L50 lock	TZ-UKH40U002PL50
1 Painted steel power feed panel with 3 power outlets (12A) and 2 USB ports (1 A, 1 C)	TZ-M060T2P
1 Battery charger shelf	RH54-26
1 Half width shelf	RH60-3008
1 Wire spool and roll holders	WM9P-2601
1 Laptop arm	WM06-42
1 Can holder	WM9D-09
1 Plastic bin rail	WM9C-09
1 Tool rail	RH47-6001
1 Balancer trolley	WM48-01
1 Tool balancer	WM49-01

60"W HUTCH

PRODUCT NO.	W×D×H
TZ-JKG40U2104P	60"×27"×40"
1 Hutch with painted steel utility panels, LED light with motion sensor, 1 L50 lock	TZ-UKH40U002PL50
1 Painted steel power feed panel with 3 power outlets (12A) and 2 USB ports (1 A, 1 C)	TZ-M060T2P
1 Battery charger shelf	RH54-26
1 Half width shelf	RH60-3008
1 Wire spool and roll holders	WM9P-2601
1 Laptop arm	WM06-42
1 Can holder	WM9D-09
1 Plastic bin rail	WM9C-09
1 Tool rail	RH47-6001
1 Balancer trolley	WM48-01
1 Tool balancer	WM49-01

4 EASY STEPS

You can quickly and easily configure your own layout in just four steps.

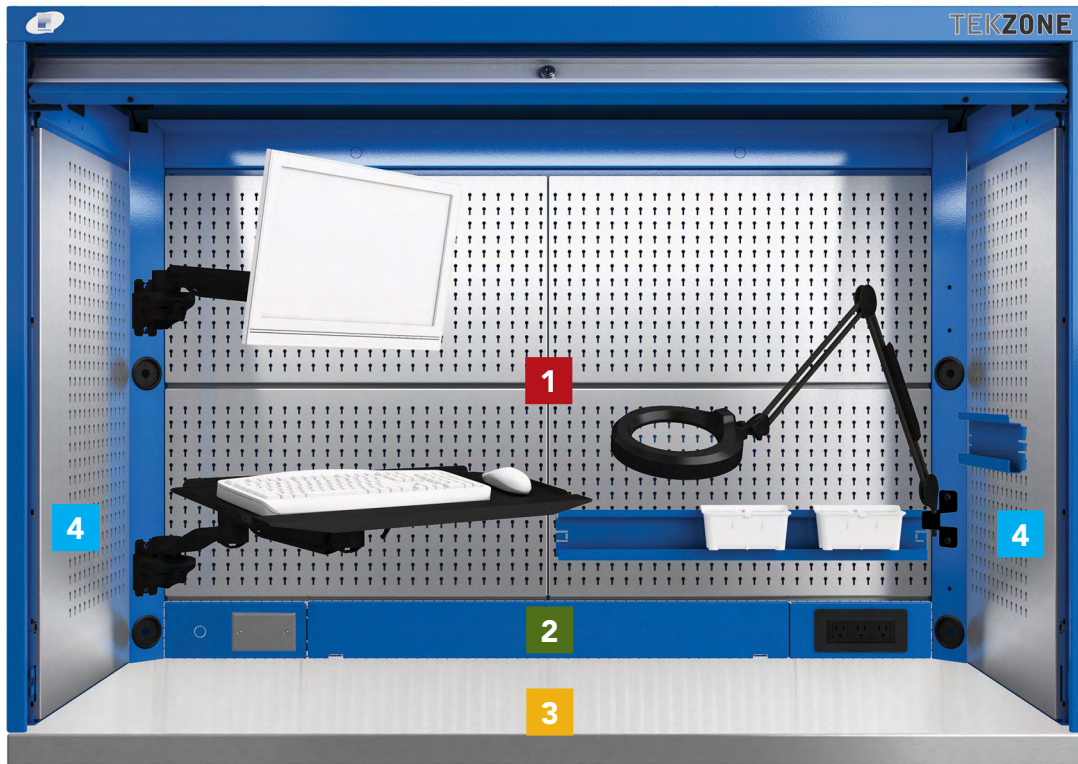

STEP 1: CHOOSE PANELS

Choose the panels you want in the hutch: panels for plastic bins, utility panels or finishing panels. To ensure your TekZone hutch remains bright, you can choose between stainless steel or painted steel panels. For painted steel panels, we recommend choosing one of the following five paint colors:

White 616	Frost White 061	Light Gray 071	Beige 041	Modern Gray 745

STEP 2: CHOOSE POWER FEED PANEL

Then you choose a power feed panel from the following five models:

PRODUCT NO.	DESCRIPTION
TZ-M0_ _ 00 _	Cover panel, no outlets
TZ-M0_ _ T1 _	3 power outlets (12A), knockout and perforation
TZ-M0_ _ T2 _	3 power outlets (12A), 2 USB ports (1 A, 1 C)
TZ-M0_ _ T3 _	3 power outlets (12A), 2 USB ports (1 A, 1 C), knockout and perforation
TZ-M0_ _ T4 _	3 power outlets (12A)

STEP 3: CHOOSE TOP

In this step you choose which type of work surface best meets your needs:

HEIGHT	TOPS FOR R CABINETS				
	PAINTED STEEL	STAINLESS STEEL	LAMINATED HARDWOOD	NITRILE 3/16"	NEOPRENE 1/4"
1 3/4"	RC37	RC35	WS14	-	-
Thin	RH10	RH11	-	-	-
Mat	-	-	-	RH91	RH90

HEIGHT	TOPS FOR R WORKSTATIONS				
	PAINTED STEEL	STAINLESS STEEL	LAMINATED HARDWOOD	NITRILE 3/16"	NEOPRENE 1/4"
1 3/4"	RC37	RC35	WS14	-	-
Mat	-	-	-	RH91	RH90

HEIGHT	TOPS FOR WS WORKSTATIONS				
	PAINTED STEEL	STAINLESS STEEL	LAMINATED HARDWOOD	NITRILE 3/16"	NEOPRENE 1/4"
1 3/4"	WS10	WS12	WS14	-	-
Mat	-	-	-	RH91	RH90

NOTE: The TekZone Hutch must be installed on a work surface.

STEP 4: ACCESSORIES

Finally, you can equip the hutch with accessories of your choice.



1 DIMENSIONS AND PANEL TYPES

UTILITY PANELS

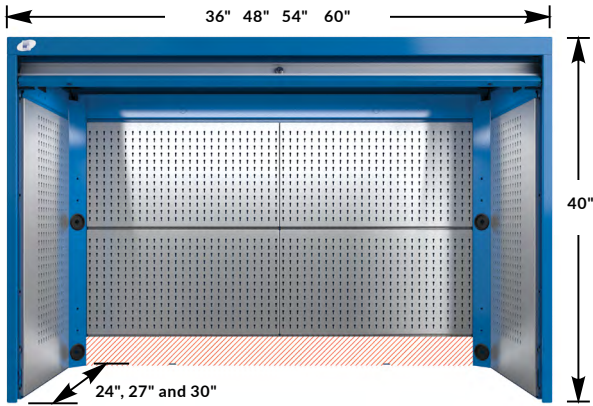

SPECIFY THE WIDTH AND DEPTH REQUIRED AND THE PANEL FINISH

Width: 36" = E, 48" = H, 54" = J, 60" = K

Lock: L3, L50

Depth: 24" = E, 27" = G, 30" = H

TZ-U 40U002

Painted steel = P, Stainless steel = S

UTILITY AND PLASTIC BINS PANELS

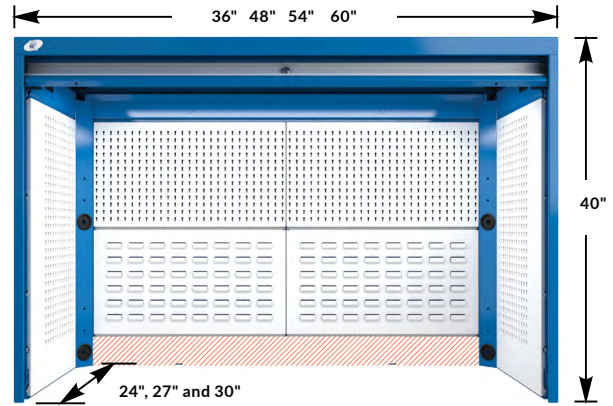

SPECIFY THE WIDTH AND DEPTH REQUIRED

Width: 36" = E, 48" = H, 54" = J, 60" = K

Lock: L3, L50

Depth: 24" = E, 27" = G, 30" = H

TZ-U 40X002P

Painted steel = P

UTILITY AND FINISHING PANELS

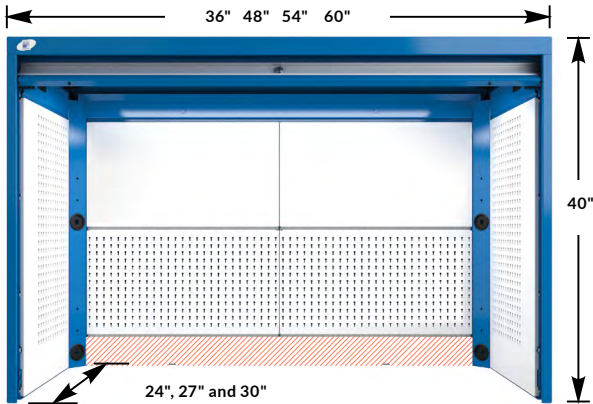

SPECIFY THE WIDTH AND DEPTH REQUIRED AND THE PANEL FINISH

Width: 36" = E, 48" = H, 54" = J, 60" = K

Lock: L3, L50

Depth: 24" = E, 27" = G, 30" = H

TZ-U 40X004

Painted steel = P, Stainless steel = S

BACK PANELS LOGIC

36" wide: Two full-width 15" high panels

48", 54" and 60" wide: Four half-width 15" high panels

BACK AND SIDE PANELS CAPACITY

Panel capacity: 100lb per panel

2 POWER FEED PANEL



- The power feed panels include a 10' power cord
- The center panel can be used to manage power and network cables

SPECIFY THE WIDTH AND FINISH REQUIRED

Width: 36" = 36, 48" = 48, 54" = 54, 60" = 60

Painted steel = P, Stainless steel = S

TZ-M0 T4

FINISHING PANEL NO OUTLETS



3 POWER OUTLETS (12A), KNOCKOUT AND PERFORATION



TZ-M0__T1_

3 POWER OUTLETS (12A), 2 USB PORTS (1 A, 1 C), KNOCKOUT AND PERFORATION



TZ-M0__T3_

3 POWER OUTLETS (12A) AND 2 USB PORTS (1 A, 1 C)



TZ-M0__T2_

3 POWER OUTLETS (12A)



TZ-M0__T4_

3 CHOICE OF TOP

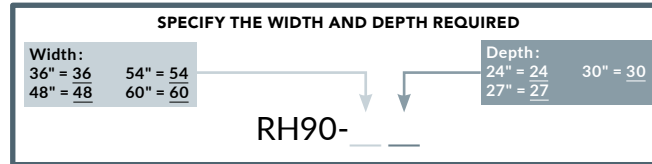

THIN PAINTED STEEL TOP



RH10-__-__ For R cabinets

1 3/4" PAINTED STEEL TOP*



RC37-__-__-02 For R cabinets or R workstations
WS10-__-__-02 For WS workstations

1 3/4" LAMINATED HARDWOOD TOP*



WS14-__-__-02 For R cabinets, R workstations or WS workstations

THIN STAINLESS STEEL TOP



RH11-__-__ For R cabinets

1 3/4" STAINLESS STEEL TOP*



RC35-__-__-02 For R cabinets or R workstations
WS12-__-__-02 For WS workstations

PROTECTIVE MAT**



RH90-__-__ 3/16" Oil resistant nitrile
RH91-__-__ 1/8" Neoprene

NOTES: * These tops are pre-punched for easy installation of the TekZone Hutch.

**Top to be ordered separately.

The TekZone Hutch must be installed on a work surface.

4 ACCESSORIES

CAN HOLDER

WM9D



- Ideal for storing cans and other containers of different sizes
- Compatible with side and back panels
- 3"D and 4"H

PRODUCT NO.	WIDTH	COMPATIBILITY
WM9D-09	9"	24" D
WM9D-12	12"	27" D
WM9D-15	15"	30" D

BATTERY CHARGER SHELF

RH54



- Hooks onto back utility panels at the desired height
- 25" usable width accommodates several chargers at once
- Includes a non-slip protective mat
- Includes a built-in power bar with six power outlets (15A / 120V, with switch, circuit breaker and 15' power cord)
- Includes storage space for cable management

PRODUCT NO.	WIDTH
RH54-26	26"

ACCESSORIES

SLOPED TOP

RH89



- Keeps the workspace clean and safe while reducing clutter
- 8"H

PRODUCT NO.	W x D
RH89-362408	36" x 24"
RH89-362708	36" x 27"
RH89-363008	36" x 30"
RH89-482408	48" x 24"
RH89-482708	48" x 27"
RH89-483008	48" x 30"
RH89-542408	54" x 24"
RH89-542708	54" x 27"
RH89-543008	54" x 30"
RH89-602408	60" x 24"
RH89-602708	60" x 27"
RH89-603008	60" x 30"

PLASTIC BIN RAIL

WM9C



- Plastic bins hook onto the rail for efficient storage of small parts
- Compatible with RG20 plastic bins (sold separately)

PRODUCT NO.	WIDTH	USE
WM9C-09	9"	for 24"D side panels
WM9C-12	12"	for 27"D side panels
WM9C-15	15"	for 30"D side panels
WM9C-20	20"	for half-width back panels on a 48"W hutch
WM9C-23	23"	for half-width back panels on a 54"W hutch
WM9C-26	26"	for half-width back panels on a 60"W hutch
		for full-width back panels on a 36"W hutch

WIRE SPOOL AND ROLL HOLDERS

WM9P



- Ideal for wire spools or paper towel rolls
- Tube diameter: 3/4"
- Load capacity: 50lb.

PRODUCT NO.	WIDTH	USE
WM9P-0901	9"	for 24"D side panels
WM9P-1201	12"	for 27"D side panels
WM9P-1501	15"	for 30"D side panels
WM9P-2001	20"	for half-width back panels on a 48"W hutch
WM9P-2301	23"	for half-width back panels on a 54"W hutch
WM9P-2601	26"	for half-width back panels on a 60"W hutch
		for full-width back panels on a 36"W hutch

SHELF AND DIVIDER

RH60 / RH61

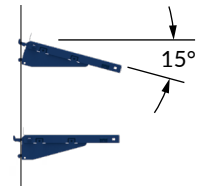

- Hooks onto back utility panels at the desired height
- Can be installed at a right angle or angled 15°
- The shelf is reversible and its edge can act as a back stop for plastic bins and ring binders
- Load capacity: 100lb. (evenly distributed)
- Compatible with SH52-1206 dividers in 2" increments c/c
- Width compatibility:
 - 36"W hutches: full-width shelf
 - 48"W, 54"W and 60"W hutches: half-width shelf
- Add 08 to the product number for an 8"D shelf and 12 for a 12"D shelf.

PRODUCT NO.	WIDTH	COMPATIBILITY
RH60-24__	20"	Half-width shelf for 48"W hutch
RH60-27__	23"	Half-width shelf for 54"W hutch
RH60-30__	26"	Half-width shelf for 60"W hutch
RH61-36__	29"	Full-width shelf for 36"W hutch
SH52-1206		Divider

TABLET ARM

WM06

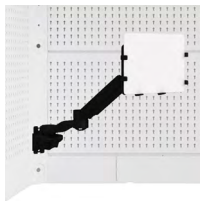

- Compatible with most tablets on the market
- The clamps and mount have a non-slip surface to keep the tablet stable
- The articulating arm with two joints provides extra adjustment options
- Tablet can be rotated and tilted
- Compatible tablet sizes:
 - Small: 7 7/8"W to 10"W
 - Large: 9 7/8"W to 12 1/4"W

PRODUCT NO.	TABLET SIZE
WM06-62-01	Small
WM06-62-02	Large

LCD MONITOR ARM AND KEYBOARD & MOUSE ARM WM06

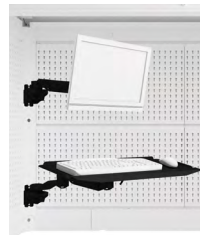

- Keyboard tray's usable area: 23 3/8"W x 8 1/2"D
- Includes an articulating arm with a single joint and an articulating arm with two joints providing extra adjustment options
- Compatible with most LCD monitors (max. 21") on the market
- Complies with VESA 75 and 100 monitor mounting standards
- Screen and tray can be rotated and tilted

PRODUCT NO.	VERSION
WM06-22	Complete Kit
WM06-02	LCD Monitor Arm
WM06-32	Keyboard & Mouse Arm

MONITOR MOUNT

RH52



- Supports a monitor compliant with the VESA 75 and 100 standards
- Includes a central cutout for cable management from the rear of the mount
- Two positions: vertical or angled 10° forward to reduce reflections
- Compatible with utility panels and finishing panels only

PRODUCT NO.
RH52-15

KEYBOARD TRAY

RH53



- Unique and heavy-duty design with palm rests
- 25"W to accommodate a keyboard and mouse
- Includes a non-slip protective mat

PRODUCT NO.
RH53-25

TOOL RAIL

RH47



- Holds one or more WM48 balancer trolleys
- Color: black
- 25lb. load capacity
- For 48"W, 54"W and 60"W hutches

PRODUCT NO.	WIDTH
RH47-4801	48"
RH47-5401	54"
RH47-6001	60"

BALANCER TROLLEY

WM48



- Inserts into a RH47 tool rail
- Color: black
- Holds a pneumatic connection

PRODUCT NO.
WM48-01

TOOL BALANCER

WM49



- For hanging tools over the work surface
- 6' metal cable with tension adjustment
- Color: black
- Load capacity: 3lb. max.

PRODUCT NO.
WM49-01

ELECTRONIC LOCK SYSTEM

L50



- Electronically locks the slide-up door
- No key required
- Up to 20 different users can be programmed
- 4- to 8-digit access codes
- Simplifies access management
- To order, specify the lock in the model by L50. For a replacement lock, see page 295



PRODUCT NO.
RH06-WW40L50

LAPTOP ARM

WM06

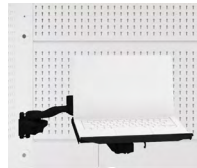

- Tray's usable area: 14"W x 12"D and it can be rotated and tilted
- Includes an articulating arm with two joints providing extra adjustment options

PRODUCT NO.
WM06-42

INTERMEDIATE SHELF AND BOTTOM SHELF

RH64/RH65

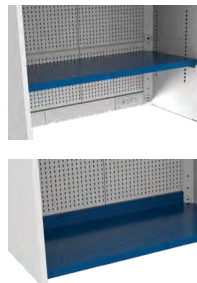

- Full-length and full-depth shelf
- 200 lb. load capacity (evenly distributed weight)
- Compatible with SH52-2106 dividers in 3" increments c/c
- RH64 Intermediate Shelf:
 - Attaches to RH35 side panels only
 - Compatible with RH20 and RH21 back utility panels; the area next to the shelf will be unusable
 - To add to a preconfigured TZ model, replace side panels with RH35 side panels
 - Not compatible with RH22 and RH23 back panels for plastic bins
 - Not compatible with the following side panels: RH32 panels for plastic bins, RH30 and RH31 utility panels and RH28 and RH29 finishing panels
- RH65 Bottom Shelf:
 - A top (see page 177) is required for joining the hutch to the cabinet underneath

PRODUCT NO.	WIDTH
RH__-3627	36"
RH__-4827	48"
RH__-5457	54"
RH__-6027	60"

NOTE: RH36 to RH41 power feed and cable management panels cannot be used with the bottom shelf.

LAMP WITH MAGNIFIER AND LED LIGHT



- Diopter: 5 (2.25x magnification)
- Installs on the back uprights with an RH50 lamp support

PRODUCT NO.	USE
RH50-01	Lamp support
7000640	Lamp with magnifier and LED light

w.w.Cannon, Inc.

Design. Layout. Build. Install.

1-800-442-3061
www.wwcannon.com