



HIGH  
SPEED  
DOORS



FRIGO 1



# TECHNICAL DATA



LOW TEMPERATURE

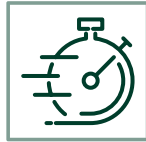

HIGH SPEED  
Up to 1 m/s



SAFE



SELF-REPAIR



OIL FREE

MAXIMUM DIMENSIONS	W 4000 mm x H 4500 mm
SPEED	<b>Max opening speed</b> Up to 1 m/s
	<b>Closing speed</b> 0,6 m/s
CYCLES TEST	1.000.000
WIND RESISTANCE	Class 2
STRUCTURE	Not self-supporting
FRAME / MOTOR COVER HOOD	<b>Standard</b> Galvanized Steel
	<b>Optional</b> Powder coated steel Stainless steel 441/316
CURTAIN	<b>Standard</b> Double curtains welded with expanded polyethylene insulating 18 mm thick.
	<b>Optional</b> • FDA (white) • Antistatic
SLIDING SYSTEM	Patented sliding system with high density Polyzene self-lubricant equipped of sliding zipper directly on curtain
CONTROL PANEL	<b>Standard</b> Powder coated Steel box IP54 (300 x 500 x 150 mm)
	<b>Optional</b> • Stainless steel • PVC box IP65 (300 x 400 x 150 mm)
	Inverter system 50/60 Hz with absolute encoder
	Power supply 1-ph, 230V max 16A
	Power supply 3-ph, 400V max 10A
	Power supply 3-ph, 230V max 16A
	Start/ Stop button
	2 free contacts (door open/ closed/ alert)
	Automatic/ Manual Interlocking between 2 doors
	IP rating for motor and control panel IP54
WIRING	Plug and Play system IP65
SAFETIES	<b>Standard</b> • Photocells set IP65 • Anti-jam sensor reverse • WiFi safety edge IP65
	<b>Optional</b> • Multi ray light curtain barrier H2500 IP67
EMERGENCY OPENING	<b>Standard</b> Hand crank
	<b>Optional</b> • Chain system • Counterweight system • UPS Battery
HEATING-KIT	Heater on electrical components and mechanical, heating cable 30W ml

DynamicRoll® **FRIGO 1** is a self-repairing roll up door with a special layered curtain composed of PVC/ polyethylene expanded/ PVC curtain.

The insulating segments on the curtain prevent icing creating a thermal cut with a continuous insulation on curtain. Thickness of curtain is of about 18mm.

The frame structure can be equipped with heating cables placed in the sliding system and in connections to prevent condensation and icing of curtain.

These features make door ideal for refrigeration field to divide environments with different temperatures with humidity less than 30%.

## EN13241 CERTIFICATION

STANDARD	RIF.	TEST ACC.	RESULTS
WATER PERMEABILITY	EN 12425	EN 12489	Class 1
WIND LOAD	EN 12424	EN 12444	Class 2
AIR PERMEABILITY	EN 12426	EN 12427	Class 1
SAFE OPENINGS	EN 12453	EN 12445	✓
MECHANICAL RESISTANCE	EN 12604	EN 12605	✓
UNINTENDED MOVEMENTS	EN 12604	EN 12605	✓
THERMAL TRANSMITTANCE	EN 12428	EN 12428	2,2 W/m <sup>2</sup> K
PERFORMANCE (CYCLES)	EN 12604	EN 12605	1.000.000

Values can change depending on door dimensions

## ADVANTAGES

- Self-repairing
- Rapid
- Sealing
- Noiseless
- No rigid elements inside the curtain for 100% safety
- Plug & play (easy to install)
- Low maintenance
- Thermal K insulator - 2.2 Wm2K



## ADVISING OPERATIVE TEMPERATURE

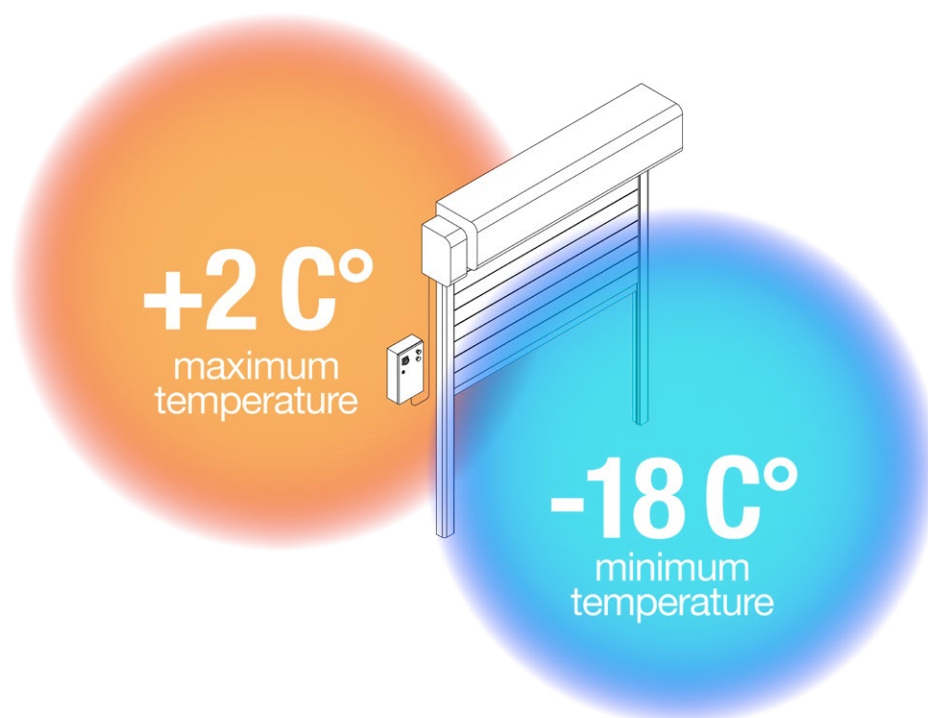

< 30%  
HUMIDITY

# DOOR SPACE REQUIREMENTS

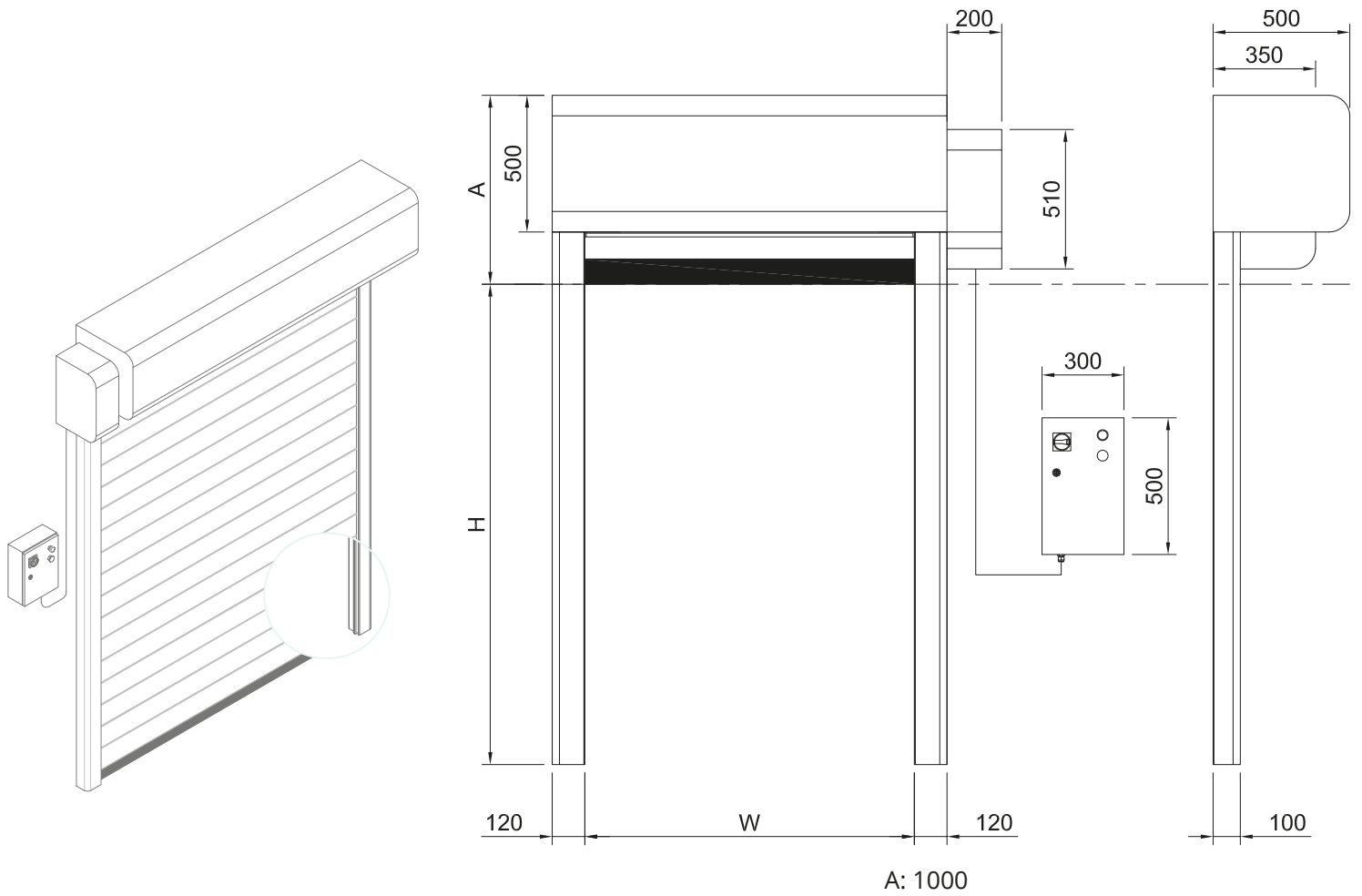

# FIXING DETAILS

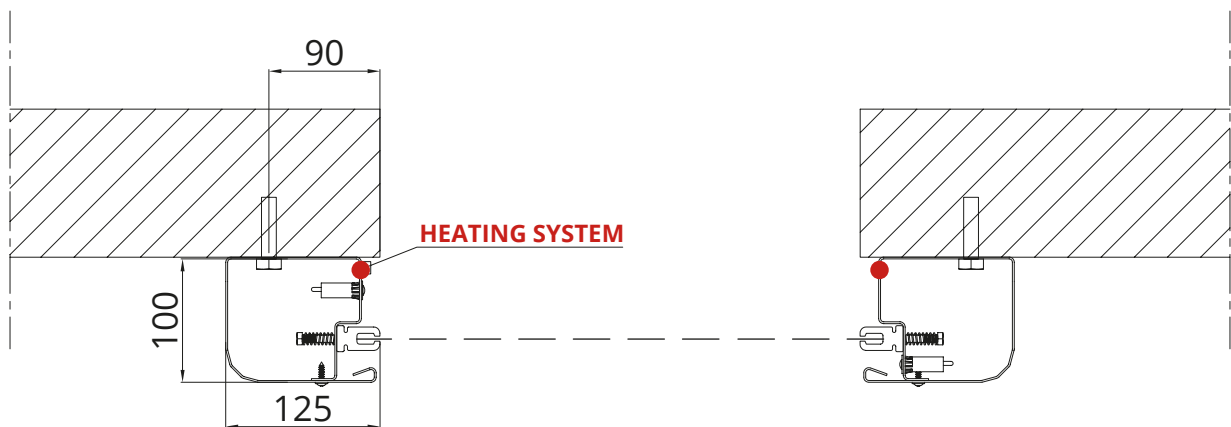

# PVC CHARACTERISTICS

## STANDARD PVC

### Composition and tests

EXTERNAL SIDE			
Material	Finishing	Color	Thick
PVC	Opaque	18 standard	0,7 mm
FABRIC			
Material	N. tarps	Title	EN 2286-2
PES	1	1100Dtex 12x12	900 g/m <sup>2</sup>
INTERNAL SIDE			
Material	Finishing	Color	Thick
PVC	Rough	18 standard	0,2 mm
COLD RESISTANCE			
ISO 4675/90 -50°C ±5			
HYDROLYSIS TEST			
75°C 95% humidity none variation			
GAS OIL TEST			
- none variation			
MARINE WATER TEST			
none variation			
OZONE TEST			
ISO 3011 none crack			
T. STORAGE			
(°C) -30 +65			
FLAME TEST			
ISO 3795 < 100 mm/min			
PERFORATION			
RINA 3.A1.2.7 (N) > 100			
EXERCISE 7 days -70°C			
ISO 6065 none variation			

### Characteristics

<b>THICK</b> ISO 2286/3 (mm) 0,9±0,1
<b>WEIGHT</b> ISO 2286/2 (kg/m <sup>2</sup> ) 0,90±0,1
<b>LOAD BREAK</b> ISO 1421 6000 N/50mm
<b>WARP EXTENSION</b> ISO 1421 4300 N/50mm
<b>TEXTURE EXTENSION</b> ISO 1421 4000 N/50mm
<b>WARP BREAK</b> dIN 53363 (N) > 600
<b>TEXTURE BREAK</b> dIN 53363 (N) > 530
<b>ADHESION</b> dIN EN ISO 2411 130 N/50mm
<b>EEC CONFORMITY</b> - Yes
<b>SPECIFIC USE</b> industry, refrigerators, car washes, supermarkets, warehouses
<b>ASSOCIATION</b> -

### Colors



FDA (Food Drug Administration) certified pvc available

## OPTIONAL ACCESSORIES

### RADAR



OPENING POINT  
RADAR TOF/SPOT  
for internal use only



INFRARED RADAR  
with cross-movement  
adjustment



INFRARED RADAR  
motion and presence  
(pedestrian/forklift) radar

### TRAFFIC LIGHTS



GREEN FIXED STANDARD  
traffic light



RED FIXED STANDARD  
traffic light



LED TRAFFIC LIGHT  
with countdown



LED TRAFFIC LIGHT  
BARRIERS  
(connection card included)

### BUTTONS



OPENING GREEN  
BUTTON  
with box



OPENING BLACK  
BUTTON  
with box



FREEZE STOP  
BUTTON  
with box



NO TOUCH  
BUTTON



TRAFFIC LIGHT  
BUTTON  
DUAL-FUNCTION  
opening and  
intermittent door  
opening/closing  
signaling



WIND GAUGE



KEY SELECTOR



REMOTE CONTROL



BOLLARD B-PROTECT



PULL CORD SWITCH



MAGNETIC LOOP DETECTOR

**w.w.Cannon, Inc.**

Design. Layout. Build. Install.

1-800-442-3061

www.wwcannon.com