



WILGARD® MT SERIES GUARD RAIL GATE

Wilgard® MT Series Guard Rail can now be configured with a swing gate that allows for forklifts and personnel to quickly access work areas. All guard rail and gate components include necessary hardware and anchors.

Highlights

- Create entry/exit points along Wilgard MT Guard Rail Systems
- Available in any Wilgard MT rail length
- Prevents workers' compensation claims
- Directs pedestrian and forklift traffic flow



48-Hour quickship available for standard sizes!

HOW IT WORKS

Wilgard MT series' guard rail gate ships to your location with all necessary hardware required for installation.

For use in a new guard rail system, specify the size of gate opening needed so that correct gate rail lengths can be provided (custom gate rail lengths available). The Wilgard MT series gate can also be integrated into existing Wilgard MT series guard rail systems.

Once installed, the gate rolls along a spring-loaded caster for smooth operation and locks in place when not in use. It provides a visible barrier that matches the appearance of Wilgard MT guard rail systems.



WILGARD® GUARD RAIL

WILGARD® MT SERIES GUARD RAIL GATE

REAR VIEW

(LATCH SIDE)

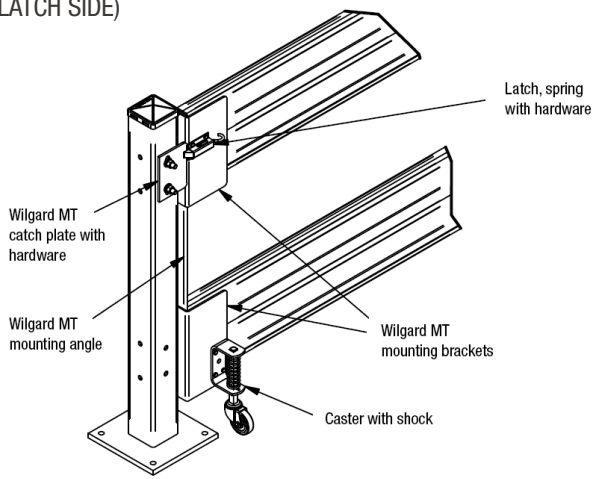

FRONT VIEW

(HINGE SIDE)

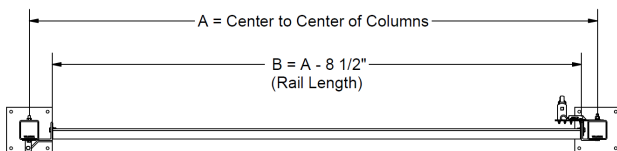
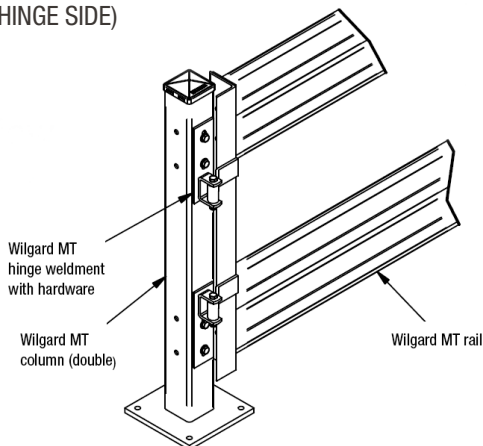

SPECIFICATIONS

- Columns: 4" x 4" x 3/16" structural tube; 18" H single rail; 44" H double rail; and 44" H triple Rail
- Base Plates: 10" x 10" x 5/8" plate steel
- Anchors: 1/2" x 5" wedge bolts (included)
- Post Cap: Zinc plated snap-on steel cap
- Rails: Corrugated 12 gauge steel guard rails, 12" H with hemmed / rolled edges
- Lengths: 2 ft. – 10 ft. in one foot increments
- Rail Hardware Pack: (4) 1/2" x 5-1/2" thru bolts, nuts, and flat washers
- Column Hardware Pack: (4) 1/2" x 5" wedge bolts, yellow plastic plugs for unused holes, and zinc plated snap-on steel cap
- Caster with Shock: 125 lb., 3" dia. x 13/16" wide wheel
- Spring-loaded latch keeps gate closed when not in use
- All hardware included with gate kit components

| Gate Components | Part # | Notes |
|---------------------|--------|------------------------------------|
| Wilgard MT Gate Kit | WMSG | Requires (2) rails and (2) columns |

| Wilgard MT Column | Part # | Height | Weight (with hardware) |
|--------------------|--------|--------|---------------------------|
| Double Rail Column | WCM44 | 44" | 52 lbs. |

| Wilgard MT Rail | Part # | Rail Lengths | Weight (with hardware) |
|-----------------|--------|--------------|---------------------------|
| 10' Guard Rail | WM10 | 116" | 67 lbs. |
| 9' Guard Rail | WM9 | 104" | 61 lbs. |
| 8' Guard Rail | WM8 | 92" | 55 lbs. |
| 7' Guard Rail | WM7 | 80" | 49 lbs. |
| 6' Guard Rail | WM6 | 68" | 43 lbs. |
| 5' Guard Rail | WM5 | 56" | 37 lbs. |
| 4' Guard Rail | WM4 | 44" | 31 lbs. |
| 3' Guard Rail | WM3 | 32" | 25 lbs. |
| 2' Guard Rail | WM2 | 20" | 18 lbs. |

w.w.Cannon, Inc.

Design. Layout. Build. Install.

1-800-442-3061

www.wwcannon.com



GUARDS
MEZZANINES
LIFTS
ACCESS