



WILGARD® XT SERIES GUARD RAIL GATE

Wilgard® XT-series Guard Rail can now be configured with its own gate components, offering one of the most versatile gate systems available for Wilgard XT rail. All guard rail and gate components include necessary hardware and anchors.

Highlights

- Create entry/exit points along Wilgard XT Guard Rail Systems
- Available in any Wilgard XT rail length
- Prevents workers' compensation claims
- Directs pedestrian and forklift traffic flow



48-Hour quickship available for standard sizes!

HOW IT WORKS

Wilgard XT series' guard rail gate ships to your location with all necessary hardware required for installation.

For use in a new guard rail system, specify the size of gate opening needed so that correct gate rail lengths can be provided (custom gate rail lengths available). The Wilgard XT series gate can also be integrated into existing Wilgard XT series guard rail systems.

Once installed, the gate rolls along a spring-loaded caster for smooth operation and locks in place when not in use.



WILGARD® GUARD RAIL

WILGARD® XT SERIES GUARD RAIL GATE

REAR VIEW

(LATCH SIDE)

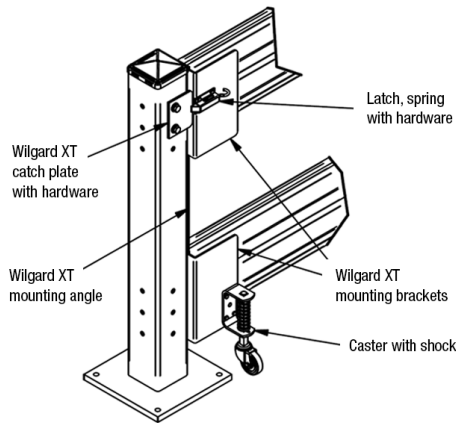

FRONT VIEW

(HINGE SIDE)

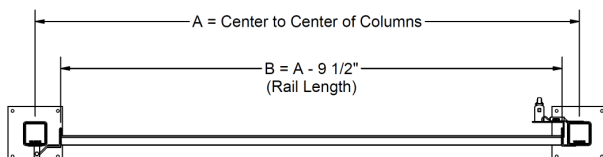
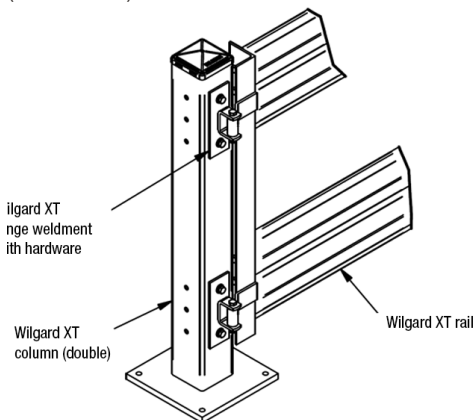

SPECIFICATIONS

- Columns: 5" x 5" x 3/16" structural tube; 18" H Single Rail; 44" H Double Rail; and 44" H Triple Rail
- Base Plates: 12" x 12" x 3/4" plate steel
- Anchors: 1/2" x 5" Wedge Bolts (included)
- Post Cap: Zinc plated snap-on steel cap
- Rails: Corrugated 11 gauge steel guard rails, 12" H with hemmed / rolled edges
- Lengths: 2 ft. – 10 ft. in one foot increments
- Rail Hardware Pack: (6) 1/2" x 1-1/2" thru bolts, nuts, and flat washers
- Column Hardware Pack: (4) 1/2" x 5" wedge bolts, yellow plastic plugs for unused holes, and zinc plated snap-on column cap
- Caster with Shock: 125 lb., 3" Dia. x 13/16" wide wheel
- Spring-loaded latch keeps gate closed when not in use
- All hardware included with gate kit components

Gate Components	Part #	Notes
Wilgard XT Gate Kit	WXSG	Requires (2) rails and (2) columns

Wilgard XT Column	Part #	Height	Weight (with hardware)
Double Rail Column	WC44	44"	75 lbs.

Wilgard MT Rail	Part #	Rail Lengths	Weight (with hardware)
10' Guard Rail	WG10	115"	71 lbs.
9' Guard Rail	WG9	103"	65 lbs.
8' Guard Rail	WG8	91"	58 lbs.
7' Guard Rail	WG7	79"	52 lbs.
6' Guard Rail	WG6	67"	45 lbs.
5' Guard Rail	WG5	55"	39 lbs.
4' Guard Rail	WG4	43"	32 lbs.
3' Guard Rail	WG3	31"	26 lbs.
2' Guard Rail	WG2	19"	19 lbs.