



# Model 91

## Standard Adjustable Forks Pallet Lifter

Adjust fork spread with a pry bar to move multiple pallet sizes off your dock, around your manufacturing floor or across your warehouse.

### Product Features:

- Converts overhead crane into lift truck
- Pry bar adjustable forks to handle multiple pallet sizes
- Counterbalanced to hang level when empty
- Complies with ASME standards

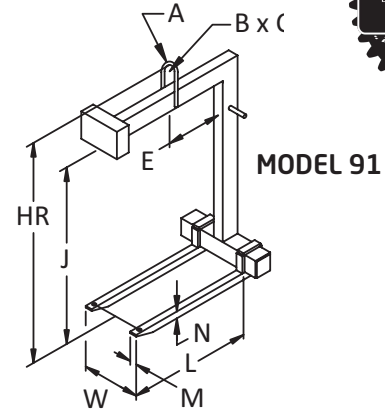

Model Number	Capacity (tons)	Dimensions (inches)											Weight (lbs.)
		Forks			W		E	Bail			J*	HR	
		L	M	N	Min.	Max.		A	B	C			
91-1-36	1	36	2	2	16	38	18	1	3	5	48	58	670
91-1-42	1	42	2	2	16	38	21	1	3	5	48	58	760
91-1-48	1	48	2	2	16	38	24	1	3	5	48	59	780
91-1 1/2-36	1-1/2	36	3	2	16	38	18	1	3	5	48	59	845
91-1 1/2-42	1-1/2	42	3	2	16	38	21	1	3	5	48	59	900
91-1 1/2-48	1-1/2	48	3	2	16	38	24	1	3	5	48	60	950
91-2-36	2	36	3	2	16	38	18	1	3	5	48	60	980
91-2-42	2	42	4	2	16	38	21	1	3	5	48	60	1060
91-2-48	2	48	4	2	16	38	24	1	3	5	48	59-1/2	1080
91-3-42	3	42	4-1/2	2-1/2	16	38	21	1-1/2	4	7	48	61-1/2	1250
91-3-48	3	48	4-1/2	2-1/2	16	38	24	1-1/2	4	7	48	61-1/2	1368
91-3-54	3	54	4-1/2	2-1/2	16	38	27	1-1/2	4	7	48	63	2005
91-4-48	4	48	5	3	19	38	24	1-1/2	4	7	48	64	1600
91-4-60	4	60	5	3	19	38	30	1-1/2	4	7	60	76	2240
91-5-48	5	48	5	3	19	38	24	1-1/2	4	7	48	65	1865
91-5-60	5	60	5	3	19	38	30	1-1/2	4	7	60	77	2190

\* Additional 3" - 4" clearance recommended above load for ease of loading and unloading the lifter.

**Not Seeing What You Want?**

Call on Caldwell's Engineering Team to custom design a pallet lifter. Get started at 800.628.42633.

# Model 96

## Heavy-Duty Adjustable Forks Pallet Lifter

This heavy-duty version of Caldwell's Model 91 handles higher capacity loads with double-frame construction. Choose for your heaviest and toughest jobs.

### Product Features:

- Forged forks gives ease of adjustment
- Smaller fork sizes gained using forged forks
- Double-frame design for heavy capacities
- Complies with ASME standards

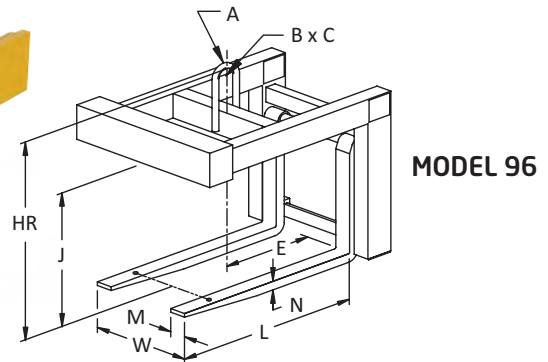

Model Number	Capacity (tons)	Dimensions (inches)											Weight (lbs.)
		Forks			W		E	Bail			J*	HR	
		L	M	N	Min.	Max.		A	B	C			
96-7 1/2-48	7-1/2	48	6	2-1/2	20	48	24	2	5	9	48	64-1/2	2400
96-7 1/2-60	7-1/2	60	6	3	20	48	30	2	5	9	60	77-1/2	3300
96-7 1/2-72	7-1/2	72	6	3	20	48	36	2	5	9	60	80	3750
96-10-48	10	48	6	3	20	48	24	2	5	9	48	68	2900
96-10-60	10	60	6	3	20	48	30	2	5	9	60	79-1/2	4300
96-10-72	10	72	7	3	20	48	36	2	5	9	60	79-1/2	4900
96-12 1/2-48	12-1/2	48	6	3	20	48	24	2	6	12	48	82	3900
96-12 1/2-60	12-1/2	60	6	3	20	42	30	2	6	12	60	82	4700
96-12 1/2-72	12-1/2	72	7	3-1/2	20	38	36	2	6	12	60	82	5500

\* Additional 3" - 4" clearance recommended above load for ease of loading and unloading the lifter.

**⚠ WARNING**

Center of the hoist and bail must be in-line with the load's center of gravity.