

Lifting Tongs

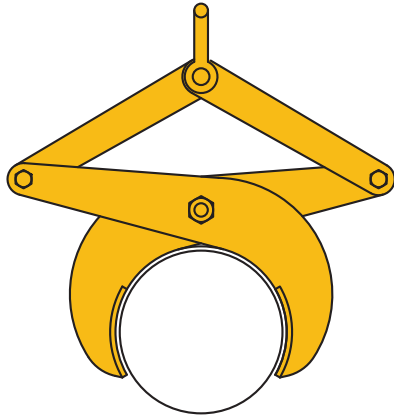

Application Ideas for Custom Friction Tongs... to lift rolls, tubes and cylindrical materials



Pipe Tongs

For our standard 108 Pipe Tongs, please see our Rig-Master® section, page F.25.

The Single Gripping Tong is used to lift cylindrical objects that are short in length such as large diameter round bar, tube or rolls of material.

We have integrated both a manual latch or the Auto-Latch mechanism into this family of tongs. The selection of the latch is dependant on the application.

The Dual Gripping Tong system supports and stabilizes longer, larger loads. The large contoured pads distribute the force applied to the load over a larger surface area. Optional pad linings, nylon or rubber pads protect the load from damage. This is ideal when handling rolls of fabric or polyethylene film.

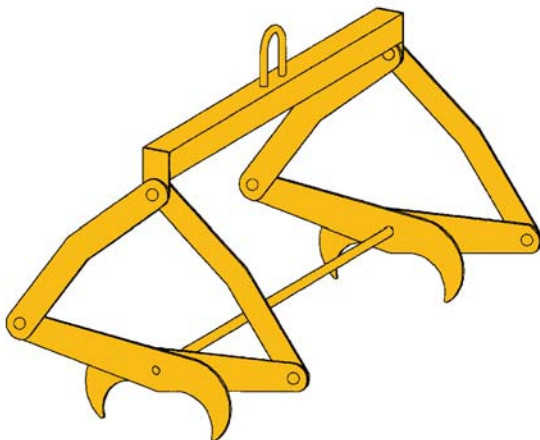
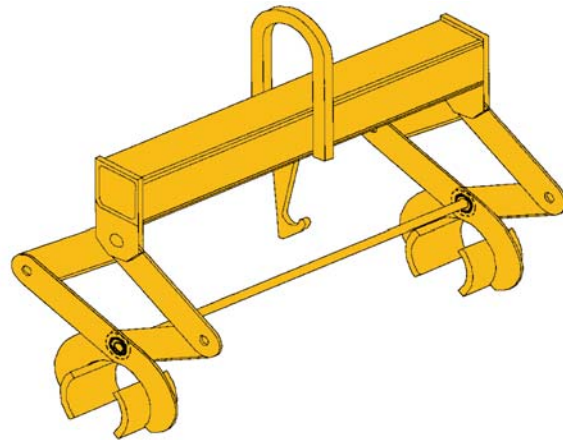

This Dual Gripping Tong system will support and stabilize longer, larger loads that can sustain the force of the entire load on a smaller surface area. When the narrow gripping arms engage the item, significant pressure will be applied. Ideal for handling bundles of steel that are round in shape.