

Model 90

Standard Fixed-Forks Pallet Lifter

Pick the capacity, fork length, and bail placement that works for your application. With 16 different configurations in our standard lineup, you're sure to find the one that works for you.

Need something different? See the Lightweight and Heavy-Duty models for more options or create a custom design to fit your exact specifications. Call 800.628.4263 for details.

Product Features:

- Converts overhead crane to lift truck
- Counterbalanced to hang level when empty
- Maintenance-free
- Allows for ease of loading/unloading in not easily accessible areas
- Complies with ASME standards

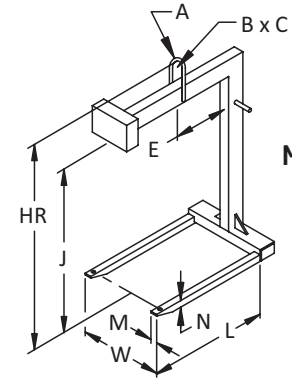

MODEL 90

Model Number	Capacity (tons)	Dimensions (inches)										Weight (lbs.)
		Forks				E	Bail			J*	HR	
		L	M	N	W		A	B	C			
90-1-36	1	36	2	2	25	18	1	6	5	48	57-1/2	292
90-1-42	1	42	2	2	25	21	1	6	5	48	57-1/2	310
90-1-48	1	48	2	2	25	24	1	6	5	48	58-1/2	371
90-1 1/2-36	1-1/2	36	3	2	25	18	1	6	5	48	58-1/2	388
90-1 1/2-42	1-1/2	42	3	2	25	21	1	6	5	48	58-1/2	432
90-1 1/2-48	1-1/2	48	3	2	25	24	1	6	5	48	58-1/2	459
90-2-36	2	36	3	2	25	18	1	6	5	48	59-1/2	448
90-2-42	2	42	4	2	25	21	1	6	5	48	59-1/2	536
90-2-48	2	48	4	2	25	24	1	6	5	48	59-1/2	627
90-3-42	3	42	4-1/2	2-1/2	25	21	1-1/2	6-1/8	7	48	61-1/2	766
90-3-48	3	48	4-1/2	2-1/2	27	24	1-1/2	6-1/8	7	48	61-1/2	823
90-3-54	3	54	4-1/2	2-1/2	30	27	1-1/2	6-1/8	7	48	61-1/2	969
90-4-48	4	48	5	3	27	24	1-1/2	6-1/8	7	48	63-1/2	1176
90-4-60	4	60	5	3	30	30	1-1/2	6-1/8	7	60	75-1/2	1393
90-5-48	5	48	5	3	30	24	1-1/2	6-1/8	7	48	63-1/2	1193
90-5-60	5	60	5	3	38	30	1-1/2	8-1/8	7	60	75-1/2	1403

* Additional 3" - 4" clearance recommended above load for ease of loading and unloading the lifter.

Model 95

Heavy-Duty Fixed-Forks Pallet Lifter

Beefed up, double-frame construction handles your heaviest lifts, from 7-1/2 to 20 tons.

Product Features:

- Double frame design for heavy capacities
- Counterbalanced to hang level when empty
- Maintenance-free
- Complies with ASME standards

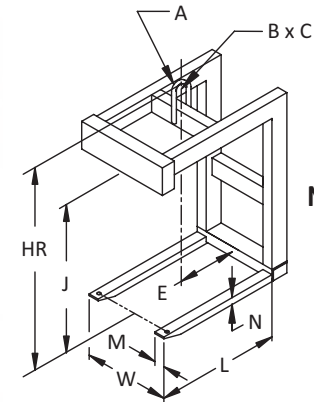

MODEL 95

Model Number	Capacity (tons)	Dimensions (inches)										Weight (lbs.)
		Forks				E	Bail			J*	HR	
		L	M	N	W		A	B	C			
95-7 1/2-48	7-1/2	48	6	2-1/2	30	24	2	5	9	48	65	1910
95-7 1/2-60	7-1/2	60	10	3	38	30	2	5	9	60	79	2400
95-10-48	10	48	10	3	30	24	2	5	9	48	69	1950
95-10-60	10	60	10	3	38	30	2	5	9	60	81	3100
95-15-48	15	48	10	3	38	24	2	6	12	60	84	2250
95-15-60	15	60	10	3	38	30	2	6	12	60	75	3800
95-20-60	20	60	7	4	38	30	2-1/4	6	12	60	88	4300
95-20-72	20	72	8-1/4	4	44	36	2-1/4	6	12	60	88	4850

* Additional 3" - 4" clearance recommended above load for ease of loading and unloading the lifter.

⚠ WARNING

Center of the hoist and bail must be in-line with the load's center of gravity.