



# Model 88

## Heavy-Duty Coil Upender

Faster, safer way to upend coils. First specify your operating voltage, then pick a capacity between 1 and 30 tons.

### Product Features:

- Fast and convenient way to upend coils to 90°
- 240 or 480 operating voltage (specify)
- Heavy-duty disc brake will stop load in any position
- Reversing magnetic starter with pendant control and 10' cord
- Stop travel/over travel limit switches

### Product Options:

- Larger platforms available
- V-Block, either standard or urethane faced (Provide coil information. Height set to accommodate a 4" pallet unless otherwise specified.)
- 180° horizontal rotation which permits loading and unloading from same side
- Lift truck fork pockets

Shown with V-block option.

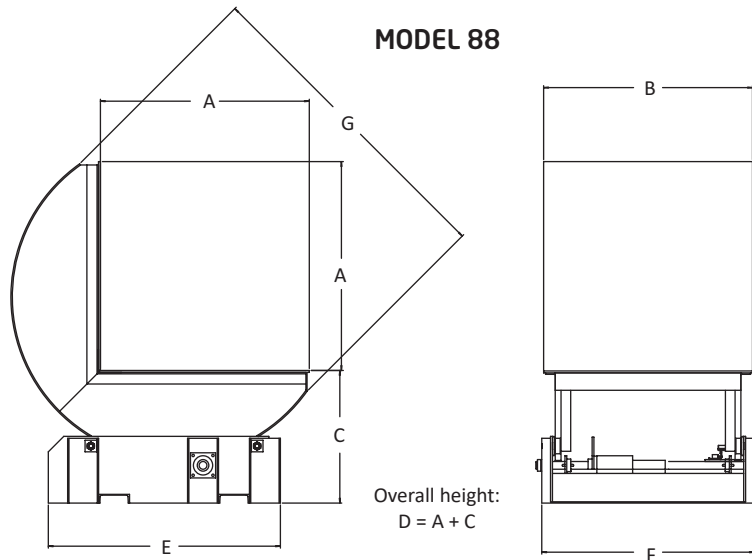

NOTE: Additional data may be required to properly size the drive system. Load information including dimensions and center of gravity should be provided.

Model Number	Capacity (tons)	Dimensions (inches)							Weight (lbs.)
		A*	B	C	Overall Height D	E	F	G	
88-1-36	1	36	36	24	60	48	36	51	1500
88-2-36	2	36	36	24	60	48	36	51	1600
88-3-42	3	42	42	24	66	56	42	60	2000
88-4-42	4	42	42	24	66	56	42	60	2200
88-5-48	5	48	48	30	78	61	48	66	2750
88-7 1/2-48	7-1/2	48	48	30	78	61	48	66	2900
88-10-54	10	54	54	30	84	60	55	74	3700
88-12 1/2-54	12-1/2	54	54	36	90	69	55	74	4000
88-15-60	15	60	60	36	96	73	60	80	4500
88-20-60	20	60	60	36	96	73	60	80	6200
88-25-72	25	72	72	43	115	88	72	96	10000
88-30-72	30	72	72	48	120	88	72	96	12000

\*Coil center of gravity must be 1/2 of 'A'. If different please specify coil or load information. Pallets must not extend over platform sides. Other sizes available, consult factory.