



# Model 88L

## Low-Platform Coil Upender

Make life a little easier for operators with this low-platform design. With the Model 88L, they have better access to coils.

### Product Features:

- Lower platform design offers easier access by operator
- Fast and convenient way to upend coils to 90°
- Requires less platform height
- Magnetic starter with 115 volt pendant control
- Double acting hydraulic cylinders
- Relief valve prevents over-capacity rotation
- Stop limit switches at each end of rotation

### Product Options:

- Larger platforms available
- Unequal platform sizes available
- V-Block, either standard or urethane faced
- 90° horizontal rotation, which permits loading and unloading from same side

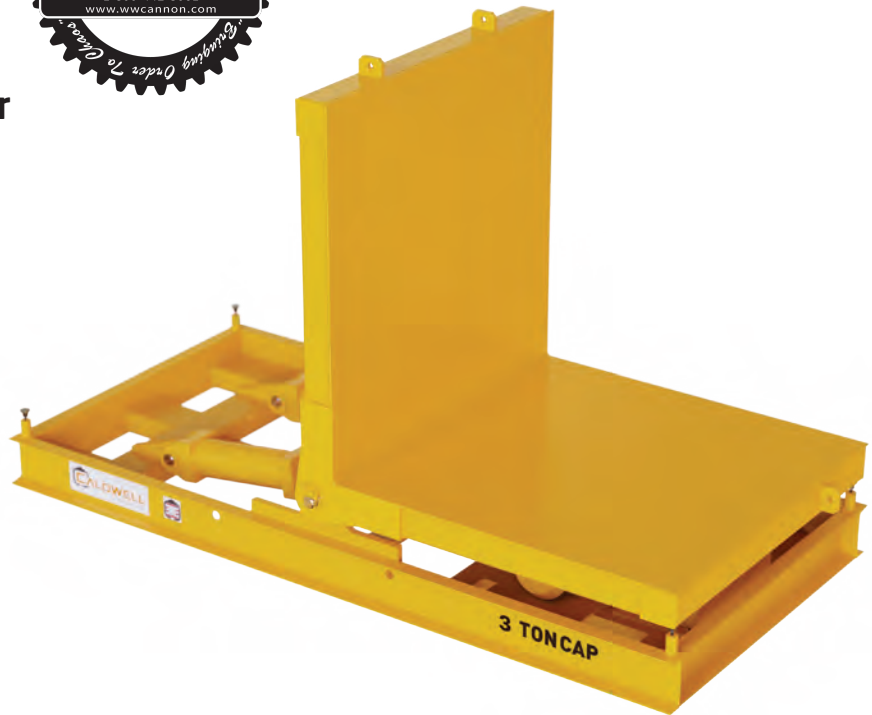

MODEL 88L

NOTE: If load is not a coil, specify center of gravity of load being rotated.

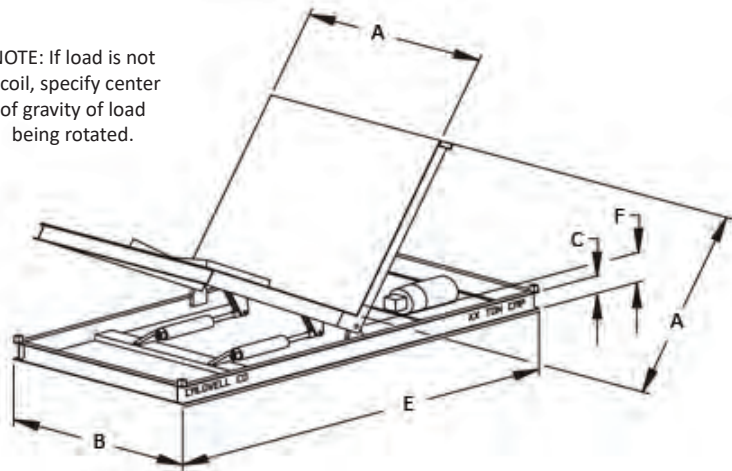

Model Number	Capacity (tons)	Dimensions (inches)						Pivot Point F*	Weight (lbs.)
		A	B	C	Overall Height	E			
88L-1/2-36	1/2	36	36	8-1/4	44-1/4	78	10.1	1500	
88L-1-36	1	36	36	9-1/4	45-1/4	78	10.1	1600	
88L-1 1/2-36	1-1/2	36	36	10-1/4	46-1/4	78	10.1	1800	
88L-2-36	2	36	36	12-1/4	48-1/4	78	10.5	2000	
88L-2 1/2-42	2-1/2	42	42	13-1/4	55-1/4	90	10.5	2200	
88L-3-42	3	42	42	14-1/4	56-1/4	90	12.1	2300	
88L-3 1/2-42	3-1/2	42	42	15-1/4	57-1/4	90	12.1	2400	
88L-4-42	4	42	42	17-3/8	59-3/8	90	12.5	2600	
88L-4 1/2-48	4-1/2	48	48	18-3/8	66-3/8	102	12.5	2800	
88L-5-48	5	48	48	19-3/8	67-3/8	102	12.5	3000	
88L-6-48	6	48	48	20-3/8	68-3/8	102	14.1	3600	
88L-7 1/2-48	7-1/2	48	48	20-3/8	68-3/8	102	15.5	5000	

Pallets must not extend over platform sides. Other sizes available, consult factory.  
\* Estimated pivot point dimension.