

# Parking Stands

## For Coil Hooks

### Features for All Model PS Parking Stands:

- Individually designed for your lifter's size and capacity – illustrations are for reference only
- Heavy-duty tubular construction
- Minimizes lifter storage space requirements
- Stabilizes lifter for personnel safety
- Allows for easy access to lifter
- Allows for easy inspection of lifter
- Minimizes time required to engage lifter with crane hook

## Model PS-CH

Used to store all C-Hook type lifters, including Models 82, 82LA, and 82RC.

 **ORDER TODAY!**

This product is customizable. To get exactly what you want, please call us at [800.628.4263](tel:800.628.4263).

## Model PS-TS

For storage of two-sided coil lifters, including Models 84, 85, and 86.

 **ORDER TODAY!**

This product is customizable. To get exactly what you want, please call us at [800.628.4263](tel:800.628.4263).

## Model PS-M-TS

For storage and maintenance of two-sided lifters with special personnel platform. Platform provides ease-of-access to drive system for maintenance and inspection of motorized units.

 **ORDER TODAY!**

This product is customizable. To get exactly what you want, please call us at [800.628.4263](tel:800.628.4263).

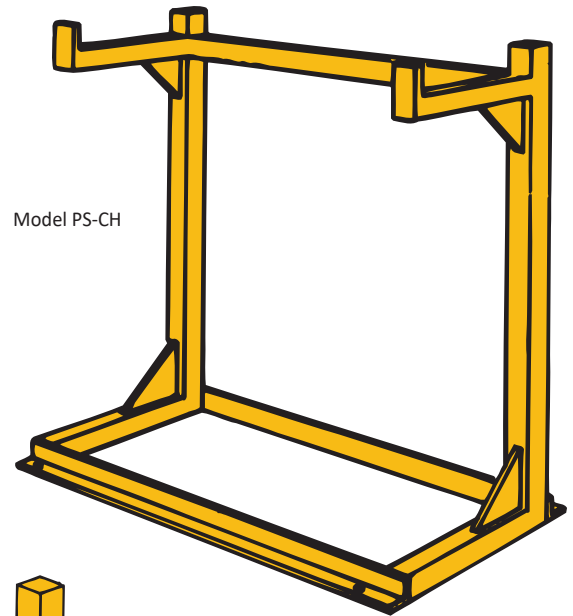

Model PS-CH

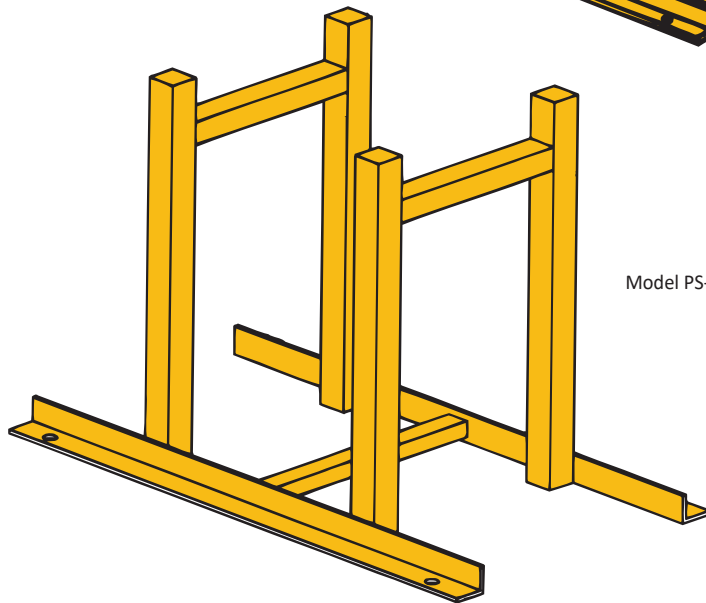

Model PS-TS

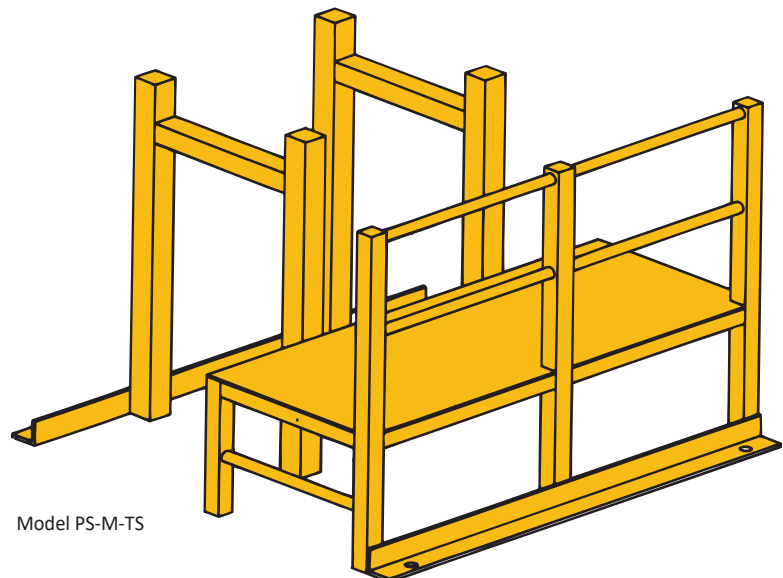

Model PS-M-TS