

Model 26P

Posi-Leveler™ Motorized Load Leveling Beam



The Posi-Leveler™ allows for motorized adjustment of the beam's central lifting point during the lift to always maintain a balanced load. This feature can be used for fine adjustment of the center of gravity during the lift. Leveling uneven loads during the lift saves rigging time and promotes a safer work environment.

Product Features:

- Motorized Posi-Leveler™ adjusts to the center of gravity during lift
- Swivel hooks with hook latches are standard
- Custom sizes are available
- Additional spreads available
- Push button pendent control with radio control option
- Standard bail adjustment 6" each side of center, with optional 12" adjustment each side of center available

Product Options:

- Power Cord Reel
- Pendent Cord Reel
- Auto-Leveler™ – see pages 96-97 for more information
- Remote Control Push-Button

Ideal For:

- Bundles
- Odd or irregular shaped loads
- Weldments
- Paper roll handling
- Sheet handling



Special 4-point Posi-Leveler™ with load guides.

MODEL 26P

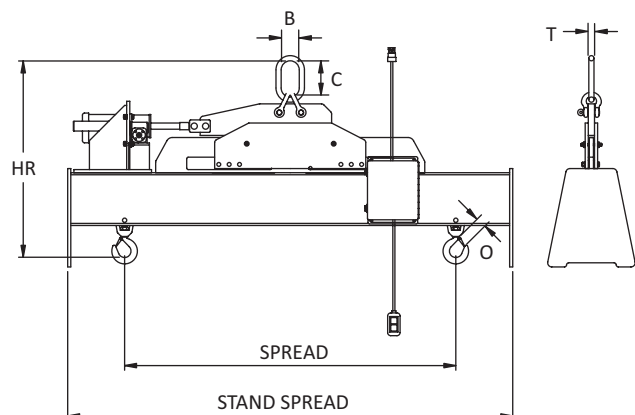



Rated Capacity (tons)	Model Number HR Headroom (in.) Weight (lbs.)	Spread (feet)								Other Dimensions (in.)	
		8	10	12	14	16	18	20	24		
2	Model Number	26P-2-8	26P-2-10	26P-2-12	26P-2-14	26P-2-16	26P-2-18	26P-2-20	26P-2-24	B=2.8 C=4.8	T=3/4 O=1
	HR Headroom	28.7	29.7	29.7	33	33	35	35	37.4		
	Weight	370	435	465	575	620	805	880	1300		
3	Model Number	26P-3-8	26P-3-10	26P-3-12	26P-3-14	26P-3-16	26P-3-18	26P-3-20	26P-3-24	B=2.8 C=4.8	T=3/4 O=1
	HR Headroom	30.3	31.3	33.3	33.3	33.3	33.3	35.3	38.3		
	Weight	405	480	610	695	760	820	1015	1300		
5	Model Number	26P-5-8	26P-5-10	26P-5-12	26P-5-14	26P-5-16	26P-5-18	26P-5-20	26P-5-24	B=3.5 C=6.0	T=1 O=1
	HR Headroom	36.8	36.8	38.8	38.8	38.8	43.8	43.8	44.8		
	Weight	620	680	875	990	1070	1640	1800	2380		
7-1/2	Model Number		26P-7 1/2-10	26P-7 1/2-12	26P-7 1/2-14	26P-7 1/2-16	26P-7 1/2-18			B=4.4 C=7.5	T=1-1/4 O=1-3/4
	HR Headroom		46.8	46.8	49.5	49.5	49.5				
	Weight		1105	1185	1680	1815	1950				
10	Model Number		26P-10-10	26P-10-12	26P-10-14	26P-10-16	26P-10-18			B=4.4 C=7.5	T=1-1/4 O=1-3/4
	HR Headroom		49.5	49.5	49.5	49.5	52.5				
	Weight		1475	1610	1780	1915	2375				
15	Model Number		26P-15-10	26P-15-12	26P-15-14					B=5.3 C=9.6	T=1-1/2 O=1-3/4
	HR Headroom		52.7	55.7	55.7						
	Weight		1625	1980	2190						
20	Model Number		26P-20-10	26P-20-12						B=6.0 C=10.0	T=1-3/4 O=2
	HR Headroom		64	64							
	Weight		1965	2130							

Load Leveling & Rotating Made Easy

Caldwell's Posi-Turner® Line makes your material handling processes more ergonomically efficient and safe, while significantly reducing product damage along the way.

Turn to pages 96-97 to learn more.

