

Model FG

Steel Drum Grippers

Choose one- or two-drum unit for efficient drum transport on the job site or in the shop.

Product Features:

- High-quality, heavy-duty construction
- Restraining chain with grab hooks
- Handles 55- or 30-gal. drums
- Lift and release drums without leaving seat
- Attaches to lift truck quickly and easily
- Minimum maintenance required
- Drums will not slip once clamped
- Quick and easy drum release

 **WARNING**

Capacity of lift truck and attachment combination may be less than capacity shown on attachment. Consult lift truck manufacturer.

Need Drum Handling Slings?

Choose from two different styles on page 24.

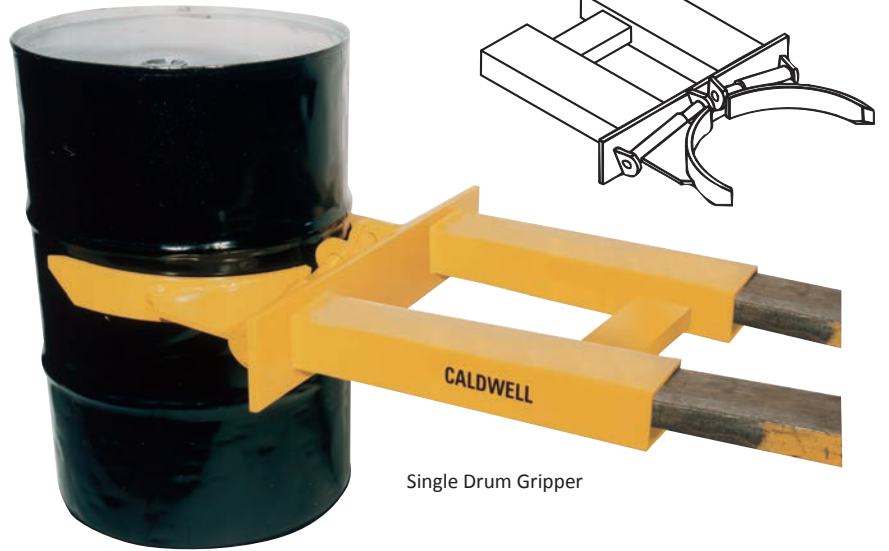

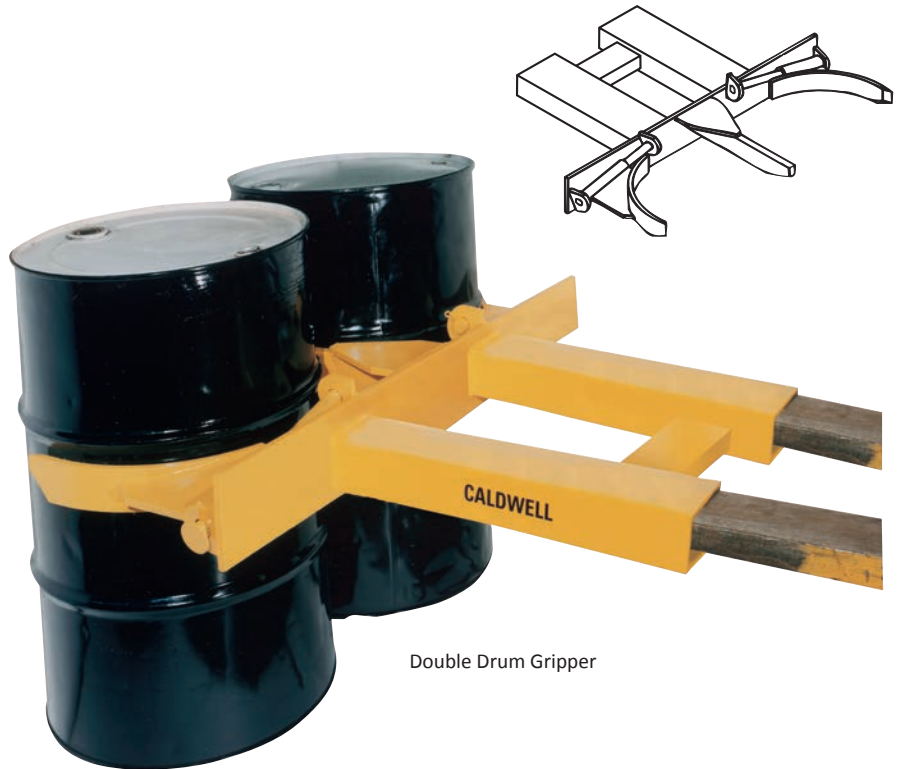

Single Drum Gripper

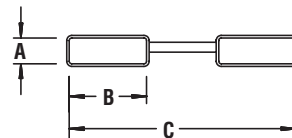

Double Drum Gripper

FORK POCKETS



Model Number	Drum Capacity Drums	Steel Drum Diameter (in.)			Fork Pockets (in.)			Weight (lbs.)
		Each (lbs.)	55 Gal.	30 Gal.	A	B	C	
FG-1	1	1500	22-3/4	18	2-1/2	7-1/2	23-1/2	230
FG-2	2	1500	22-3/4	18	2-1/2	7-1/2	23-1/2	320