

Model 21

Twin-Hoist Rotating Lifting Beams

A specially designed lifting and rotating beam using two cranes or two hoists to horizontally rotate a load. A position locking pin holds the load rotation at a designated position. Available with motorized rotation.

Product Features:

- Customize with a wide range of sizes and capacities
- Complies with ASME standards



ORDER TODAY!

This product is customizable. To get exactly what you want, please call us at 800.628.4263.

w.w.Cannon, Inc.

Design. Layout. Build. Install.

1-800-442-3061
www.wwcannon.com



MODEL 21

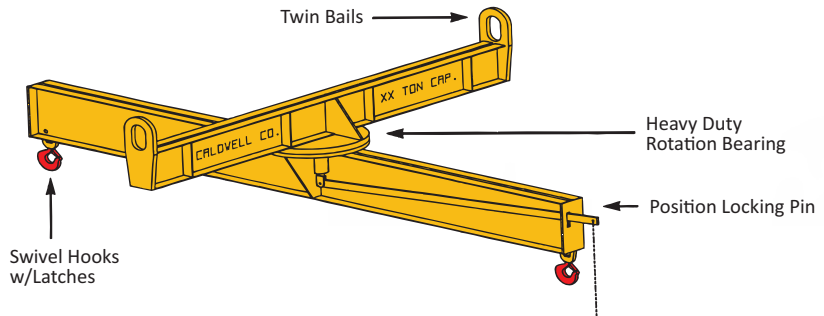

PRODUCT OPTIONS

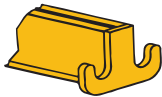

OPTION A
Twin Hooks

Used in conjunction with basket hitch slings.



OPTION B
J Hooks

Generally required to lift paper rolls or similar application. (Use Paper Roll Lifters - Application Evaluation, Page 30).

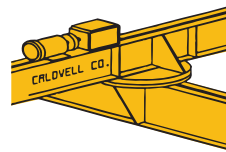

OPTION C
Motorized Rotation

Allows remote positioning of a load.

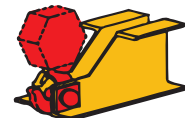

OPTION D
Lower HeadRoom Bails

Utilized when headroom must be held to a minimum. Crane hook data must be supplied, see page 30.

Model 28

Chlorine Cylinder Lifting Beam

Designed to efficiently handle standard chlorine gas cylinders. Standard size determined by the Chlorine Institute is 80-3/4" to 82-1/4" in length. Special low headroom modification is available.



MODEL 28

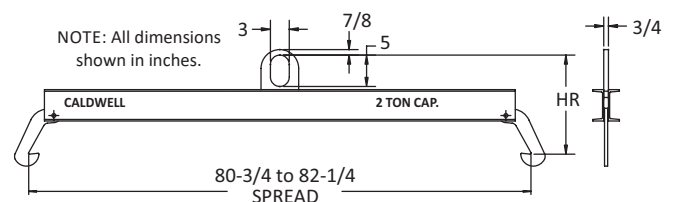

Model Number	Capacity (tons)	HR Headroom (in.)	Weight (lbs.)
28-2-80/82	2	16-1/2 - 15-1/2	105