

# Model 21

## Twin-Hoist Rotating Lifting Beams

A specially designed lifting and rotating beam using two cranes or two hoists to horizontally rotate a load. A position locking pin holds the load rotation at a designated position. Available with motorized rotation.

### Product Features:

- Customize with a wide range of sizes and capacities
- Complies with ASME standards



MODEL 21

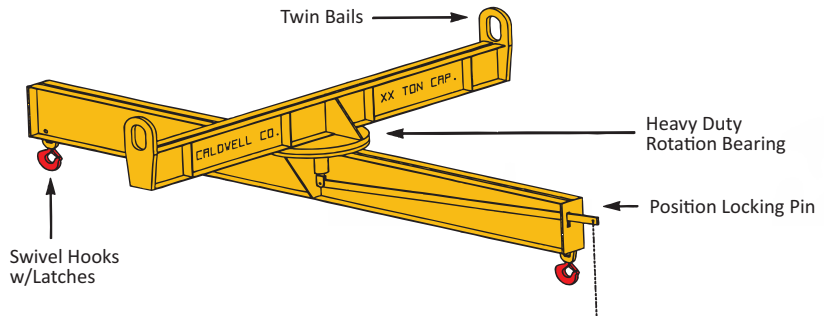

### ORDER TODAY!

This product is customizable. To get exactly what you want, please call us at 800.628.4263.

### PRODUCT OPTIONS

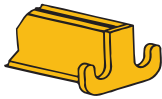

**OPTION A**  
Twin Hooks

Used in conjunction with basket hitch slings.



**OPTION B**  
J Hooks

Generally required to lift paper rolls or similar application. (Use Paper Roll Lifters - Application Evaluation, Page 30).

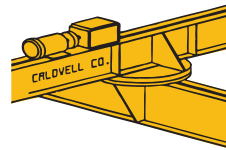

**OPTION C**  
Motorized Rotation

Allows remote positioning of a load.

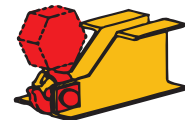

**OPTION D**  
Lower HeadRoom Bails

Utilized when headroom must be held to a minimum. Crane hook data must be supplied, see page 30.

# Model 28

## Chlorine Cylinder Lifting Beam

Designed to efficiently handle standard chlorine gas cylinders. Standard size determined by the Chlorine Institute is 80-3/4" to 82-1/4" in length. Special low headroom modification is available.



MODEL 28

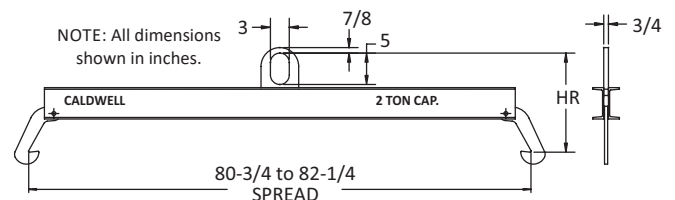

Model Number	Capacity (tons)	HR Headroom (in.)	Weight (lbs.)
28-2-80/82	2	16-1/2 - 15-1/2	105