



Model 83HW

Vertical "Eye" Coil Grab

Simple hand wheel operation adjusts legs to the appropriate I.D. for engagement and disengagement. Stock units available with capacities of 2-1/2 to 10 tons. Need something bigger or smaller? Call 800.628.4263 to talk to our Customer Service team to discuss options.



Product Features:

- Handles any size coil I.D. from 16" to 24"
- Efficient handling of vertically stacked coils
- Available with chain wheel drive or can be motorized
- Complies with ASME standards

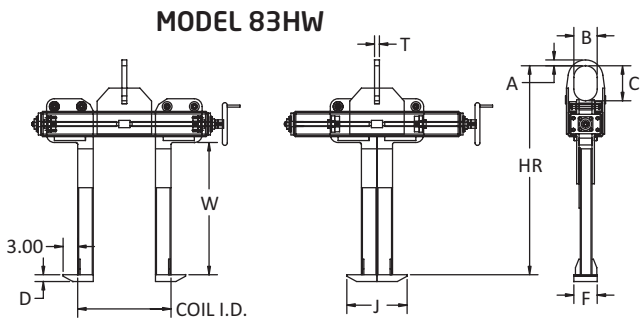

Model Number	Capacity (tons)	Dimensions (inches)											Weight (lbs.)
		Coil I.D.		Coil Width W	HR Headroom	A	B	C	T	F	D	J	
		Min.	Max.										
83HW-2-1/2-24	2-1/2	16	24	20	36	1-1/2	3	5	3/4	5	3/4	15-1/2	250
83HW-5-24	5	16	24	24	41	2	4	7	1	6	1	15-1/2	350
83HW-7-1/2-24	7-1/2	16	24	24	42	2	4	7	1	6	1	15-1/2	425
83HW-10-24	10	16	24	30	50	2-1/2	5	9	1-1/4	6	1-1/2	15-1/2	500

Other sizes available, consult factory.

Get Custom
Quotes Quickly

Distributors can get quotes for custom equipment quickly with Caldwell's Smart Spec configurator tool on the new, online Distributor Portal. Ask for access today at 800.628.4263.

