



# Model 93W

## Wheeled Pallet Lifter

Your material handlers will thank you for making it easier to move this unit from crane bay to crane bay or from one end of your facility to the other. Just tilt and roll.

### Product Features:

- Wheels allow for movement of unit without crane
- Dual lift points eliminate need for counterweight
- Extremely lightweight for ease of handling
- Complies with ASME standards

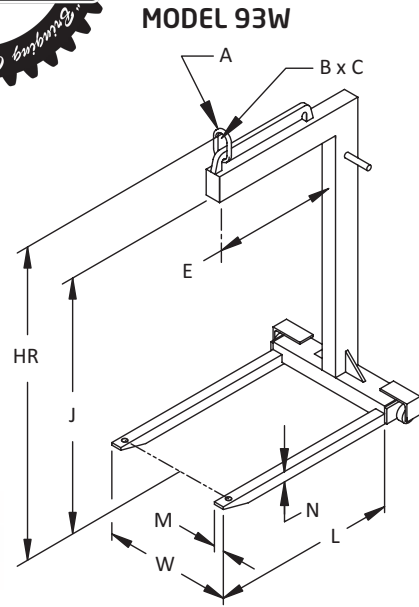

Model Number	Capacity (tons)	Dimensions (inches)										Weight (lbs.)
		Forks				E	Bail			J	HR	
		L	M	N	W		A	B	C			
93W-1-48	1	36	2	2	25	24	1/2	2-1/2	3-3/4	48	60	245
93W-2-48	2	36	4	2	25	24	3/4	2-3/4	4-1/2	48	62	405

# Model 94

## Lightweight Fixed-Forks Pallet Lifter

Lightweight, economical, and reliable – sometimes that’s just what you need. Choose from 1-, 2- or 3-ton capacities.

### Product Features:

- Dual lift points eliminates need for counterweight
- Extremely lightweight for ease of handling
- Maintenance-free; no moving parts
- Complies with ASME standards

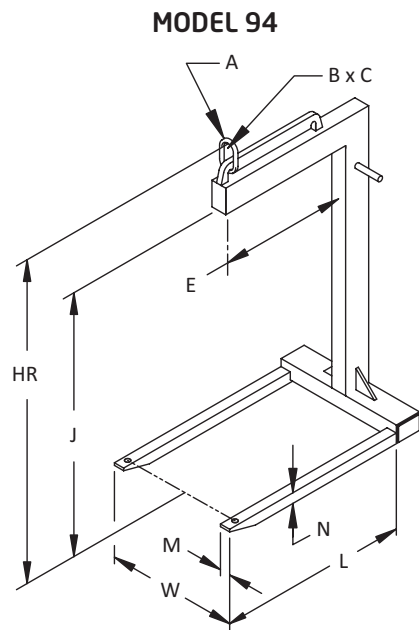

Model Number	Capacity (tons)	Dimensions (inches)										Weight (lbs.)
		Forks				E	Bail			J	HR	
		L	M	N	W		A	B	C			
94-1-48	1	36	2	2	25	24	1/2	2-1/2	3-3/4	48	58	245
94-2-48	2	36	4	2	25	24	3/4	2-3/4	4-1/2	48	62	425
94-3-48	3	36	4-1/2	2-1/2	27	24	1	3-1/2	5	48	65	610