



"Bringing Order To Chaos"

w.w.Cannon, llc.

Design. Layout. Build. Install.

1-800-442-3061
www.wwcannon.com

"Bringing Order To Chaos"

PRODUCT SUPPORT GUIDE

Push Back Guide
Structure and Cart Components



Push Back Structure Components

- 4 General Information, Product Description, Code Compliance, Availability and Shipping Locations
- 5 General Design Overview
- 6 Bolted Roll Formed Frames Components
- 8 Bolted Roll Formed Frames General Information
- 10 Bolted Post Profiles and Frames
- 11 Standard Foot Plates and Shims
- 13 Heavy-Duty Foot Plates
- 15 Heavy-Duty Shims
- 16 Assembling Selective Racking
- 18 Struts and Anchors & Bolted Reinforcement Brackets
- 19 Additional Posts
- 20 Splicing
- 21 Fixing Frame Clips
- 22 Assembling Additional Posts
- 23 Beams

27 Rack Dimensions / Design

30 Frame Height

Cart Components

31 Cart Components

33 Track PB IJR

34 Angle Front Track...Deep & Channel Front Track IHALN

37 KI-Carts PB

38 Cart Accessories, Full Cart Cover, Extra Cross Tie & Floor Level Carts

PUSH BACK RACKING

OVERVIEW

Push Back systems are designed to optimize the use of your storage area while still combining excellent selectivity and a maintenance-free design. As each pallet is loaded, it is placed on a free-rolling carriage that is literally pushed back into the system by loading additional pallets. When unloading, gravity moves the pallets forward to the aisle on the telescoping carriages, eliminating the need for reaching or driving into the rack. Everything can be accessed from a single aisle in a first-in/last-out arrangement, minimizing space requirements and maximizing the number of picking faces. Push Back systems are available in two, three, four and five deep pallet configurations.

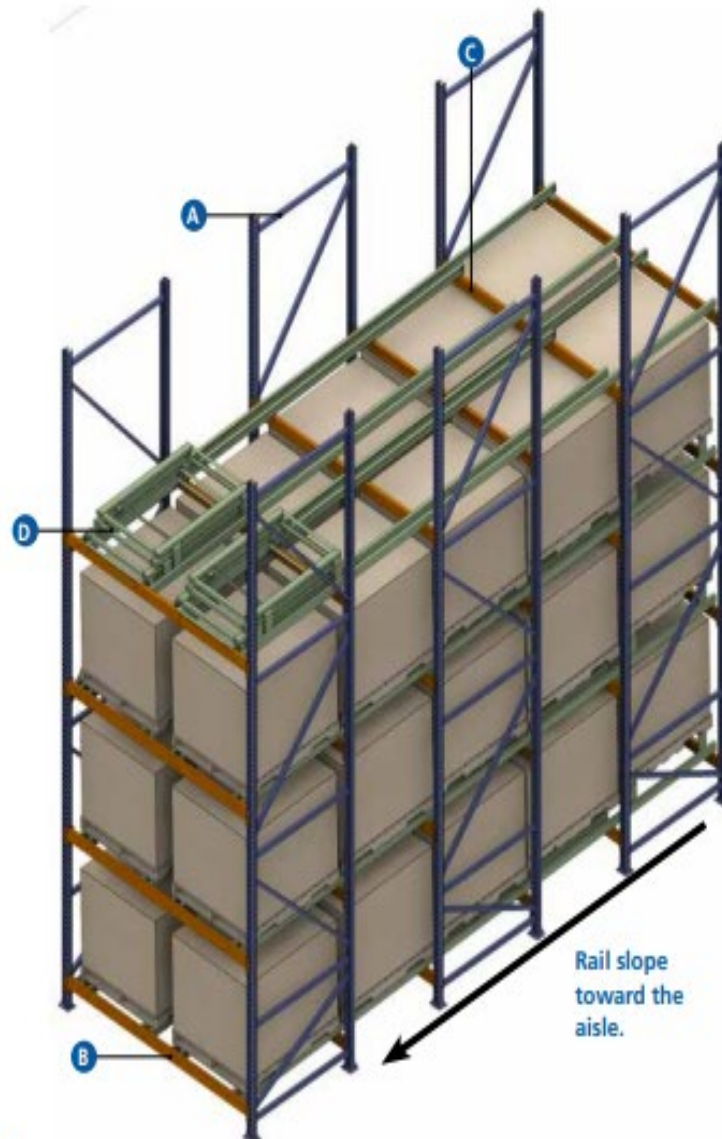

- A: Frame
- B: Front Beam
- C: Interior/Rear Beam
- D: Push Back Carts

BOLTED ROLL FORMED FRAMES

COMPONENTS

Bolted selective frames are available in a standard blue or green finish and adhere to RMI 2012 standards. Foot plates and bracing are bolted into place. In special cases, foot plates may be welded using a 1/8" fillet weld.



- A. Post (315, 314, 312, 312T)
- B. Foot Plate U (077/080, 3P, 100, 120 model) or Foot Plate J U and FJ U (3P, 100 and 120 model) or Foot Plate M U and FM U (3P, 100 and 120 model)
- C. Horizontal Strut (U C456, U C715 and U C915)
- D. Diagonal Strut (U C456, U C715 and U C915)
- E. Bolts W5/16 x 2 3/8" D931 G5 B TE1A
Bolts W5/16 x 3 7/16" D931 G5 B TE1A
Bolts W5/16 x 4 7/32" D931 G5 B TE1A
- F. 2 Washer Cups - Foot Plate TD U (Foot Plate U)
4 Washer Cups - Foot Plate TD U (Heavy Foot Plate M & J)
- G. Bolts W5/16 X 3/4" D933 G5 B TE1A

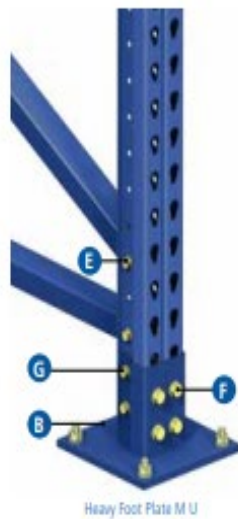
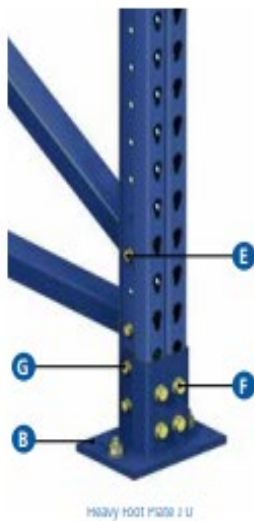

The front of the frame is located where the first two struts are adjacent to each other.



PRODUCT CODE DESCRIPTION

Standard frames are manufactured in even 12" increments for height and 2" increments for depth. Custom options are available at 2" increments for height.

For more details, contact your Interlake Mecalux representative.

- Standard depths: 36", 42" and 48".
- Available in a standard blue or green finish.
- Assembled frames available through "KI-FR" parts.
- Special frame sizes available upon request.

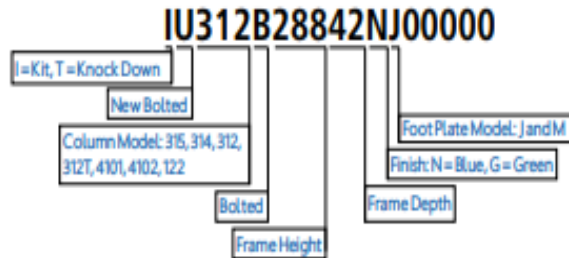
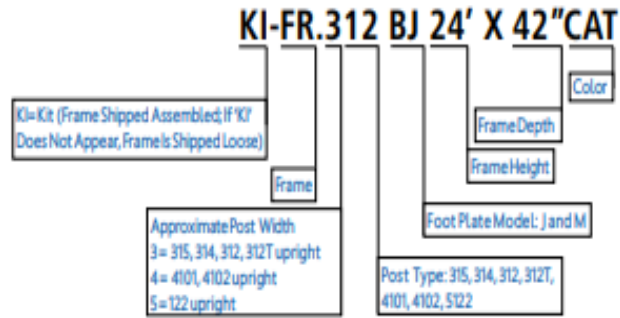

Bolted Frame Capacities (lbs)											
	Model	315	314		312		312T*		48101	48102	58122
	Gauge	15 GA (0.067")	14 GA (0.070")		12 GA (0.105")		12 GA (0.105")		13 GA (0.090")	12 GA (0.105")	12 GA (0.105")
	Height	4' - 16'	< 21'	> 21'	< 21'	> 21'	< 21'	> 21'			
Maximum Un supported Span (Hbl.)	36"	19,855	24,571	25,847	34,514	36,322	32,545	34,218	40,800	47,800	55,000
	42"	18,326	22,807	23,924	32,120	33,717	29,703	31,142	39,000	45,800	53,200
	48"	16,716	20,867	21,832	30,032	30,667	26,682	27,911	36,900	43,300	51,300
	54"	14,963	18,849	19,680	26,546	27,742	23,689	24,738	34,700	40,800	49,100
	60"	13,310	16,849	17,563	23,670	24,694	20,661	21,543	32,400	38,100	46,800
	66"	11,603	14,784	15,400	20,994	21,881	17,725	18,508	30,000	35,300	44,400
	72"	9,925	12,982	13,535	18,323	19,125	15,137	15,705	27,600	32,500	41,800
	78"	8,666	11,156	11,571	15,849	16,455	13,036	13,464	25,200	29,700	39,200
	84"	7,493	9,758	10,075	13,875	14,340	11,259	11,580	22,800	27,000	36,700
	90"	6,534	8,595	8,848	12,130	12,490	9,985	10,236	20,600	24,300	34,000
	96"	5,722	7,597	7,795	10,703	10,984	8,787	8,986	18,300	21,700	31,500
	102"	5,134	6,761	6,918	9,614	9,841	7,756	7,913	16,300	19,300	28,900
	108"	4,619	6,086	6,216	8,596	8,782	6,898	7,019	14,600	17,200	26,500
114"	4,100	5,496	5,601	7,656	7,805	6,299	6,402	13,100	15,500	24,000	
120"	3,732	4,989	5,074	6,976	7,102	5,636	5,585	11,900	14,000	21,800	

Hbl. = Height between levels

*NOTE:

- Capacities are per the 2012 RMI and 2001 AISI specifications.
- Frame capacities shown include product load plus dead load (dead load = 2% of product load).
- Maximum unsupported length is the maximum beam spacing or the distance between the floor and the top of the first beam (whichever is greater).

- Capacities are only valid when used with Interlake Mecalux published beam sizes.

- Capacities are valid for static load only.

- These capacities assume that all component parts are (1) Manufactured by Interlake Mecalux. (2) In good condition. (3) Properly installed.

BOLTED FRAMES - GENERAL INFORMATION

Frame Type	Upright	Heavy Plate	Hardware for Side Foot Plate Connection	Hardware for Foot Plate Connection	Bracing	Bolts for Strut to Upright Connection	Drawing
FR. 315	315	U 077/080 (T0052501)	-	2 WASHER CUP- FOOTPLATE TD U (T0043168) + 2 BOLTS W3/8X 1" D933 G5 B TE1A (T0029082)	U C456	BOLTS W5/16X2 3/8" D931 G5 B TE1A (T0201564)	38715H_02
FR. 314	314	U3P (T0200868)					38713H_02
FR. 312	312						38713H_02
FR. 312T	312T						39240H_02
FR. 4B101	4101	U100 (T0029078)			U C715	BOLTS W5/16X3 7/16" D931 G5 B TE1A (T0029094)	27997H_06
FR. 4B102	4102						27995H_05
FR. 5B122	5122	U120 (T0029079)	U C915	BOLTS W5/16X4 7/32" D931 G5 B TE1A (T0029095)	28002H_05		
VL-FR.314_BM	314	M U3P (T0200876)	1 BOLT W5/16X2 3/4" D931 G5 TE1A (T0029098)	2 WASHER CUP- FOOTPLATE TD U (T0043168) + 2 BOLT W3/8X 1" D933 G5 B TE1A (T0029082)	U C456	BOLTS W5/16X2 3/8" D931 G5 B TE1A (T0201564)	38859_03
VL-FR.312_BM	312						38855_03
VL-FR.312T_BM	312T						38857_03
VL-FR.4B101_BM	4101	M U100 (T0200803)	1 BOLT W5/16X3 3/4" D931 G5 B TE1A (T0203315)	U (T0043168) + 2 BOLT W3/8X 1" D933 G5 B TE1A (T0029082)	U C715	BOLTS W5/16 x3 7/16" D931 G5 B TE1A (T0029094)	31715H_07
VL-FR.4B102_BM	4102						31716H_07
VL-FR.5B122_BM	5122	M U120 (T0200804)	1 BOLT W5/16X4 3/4" D931 G5 B TE1A (T0203317)	U C915	BOLTS W5/16 x4 7/32" D931 G5 B TE1A (T0029095)	31717H_07	
VL-FR.314_BM F	314	F M U3P (T0203271)	1 BOLT W5/16X2 3/4" D931 G5 TE1A (T0029098)	2 WASHER CUP- FOOTPLATE TD U (T0043168) + 2 BOLT W3/8X 1" D933 G5 B TE1A (T0029082)	U C456	BOLTS W5/16X2 3/8" D931 G5 B TE1A (T0201564)	-
VL-FR.312_BM F	312						-
VL-FR.312T_BM F	312T						-
VL-FR.4B101_BM F	4101	F M U100 (T0203279)	1 BOLT W5/16X3 3/4" D931 G5 B TE1A (T0203315)	U (T0043168) + 2 BOLT W3/8X 1" D933 G5 B TE1A (T0029082)	U C715	BOLTS W5/16 x3 7/16" D931 G5 B TE1A (T0029094)	-
VL-FR.4B102_BM F	4102						-
VL-FR.5B122_BM F	5122	F M U120 (T0203283)	1 BOLT W5/16X4 3/4" D931 G5 B TE1A (T0203317)	U C915	BOLTS W5/16 x4 7/32" D931 G5 B TE1A (T0029095)	-	

BOLTED FRAMES - GENERAL INFORMATION

Frame Type	Upright	Heavy Plate	Hardware for Side Foot Plate Connection	Hardware for Foot Plate Connection	Bracing	Bolts for Strut to Upright Connection	Drawing
VL-FR.314_BJ	314	J U3P (T0200874)	1 BOLTW5/16X2 3/4" D931 G5 TE1A (T0029098)	2 WASHER CUPFOOTPLATE TD U (T0043168) + 2 BOLTW3/8X 1" D933 G5 B TE1A (T0029082)	U C456	BOLTS W5/16X2 3/8" D931 G5 B TE1A (T0201564)	38858_03
VL-FR.312_BJ	312						38854_03
VL-FR.312T_BJ	312T						38856_03
VL-FR.4B101_BJ	4101	J U100 (T0200800)	1 BOLTW5/16X3 3/4" D931 G5 B TE1A (T0203315)	2 WASHER CUPFOOTPLATE TD U (T0043168) + 2 BOLTW3/8X 1" D933 G5 B TE1A (T0029082)	U C715	BOLTS W5/16 x3 7/16" D931 G5 B TE1A (T0029094)	32393H_04
VL-FR.4B102_BJ	4102						32394H_04
VL-FR.5B122_BJ	5122						J U120 (T0200801)
VL-FR.314_BJ F	314	F J U3P (T0203269)	1 BOLTW5/16X2 3/4" D931 G5 TE1A (T0029098)	2 WASHER CUPFOOTPLATE TD U (T0043168) + 2 BOLTW3/8X 1" D933 G5 B TE1A (T0029082)	U C456	BOLTS W5/16X2 3/8" D931 G5 B TE1A (T0201564)	-
VL-FR.312_BJ F	312						-
VL-FR.312T_BJ F	312T						-
VL-FR.4B101_BJ F	4101	F J U100 (T0203277)	1 BOLTW5/16X3 3/4" D931 G5 B TE1A (T0203315)	2 WASHER CUPFOOTPLATE TD U (T0043168) + 2 BOLTW3/8X 1" D933 G5 B TE1A (T0029082)	U C715	BOLTS W5/16 x3 7/16" D931 G5 B TE1A (T0029094)	-
VL-FR.4B102_BJ F	4102						-
VL-FR.H5B122_BJ F	5122						F J U120 (T0203281)

- Frames could be manufactured from:

Depth (inch) min/max: From 18" to 72" each 1" (Std. sizes: 36", 42" and 48")

Height (inch) min/max:

Blue color (standard): From 4' to 39' each 2" except FR.3B15 (from 5' to 16' each 2").

Green color: From 4' to 26' each 2" except FR.3B15 (from 5' to 16' each 2").

- Standard heights are multiples of a foot.
- Standard finishes: blue electro deposition finish.
- Assembled frames available through "KI-FR" parts.

BOLTED POST PROFILES AND FRAMES

Post profiles are available in various sizes. Each profile has 7 to 9 bends, depending on the model. Post profiles have perforations every 2" on the face and the sides.

The tear drop perforations on the face are designed to secure beam placement, with the narrow section facing downwards, as shown in the drawing.

Side perforations are used for fitting struts and accessories, such as row spacers and column protectors, using 5/16" diameter grade 5 bolts.

There are different models of uprights, which vary in dimensions and gauges.

- Available in a standard blue or green finish.

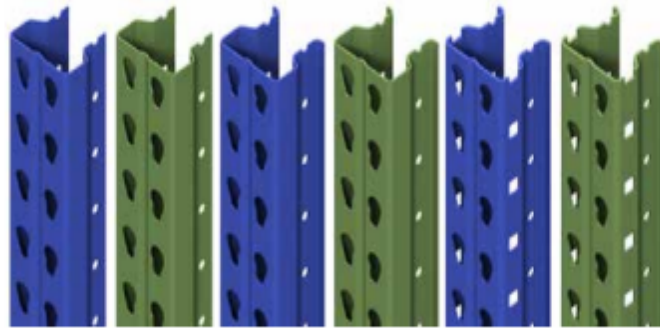

Upright 315

Upright 314, 312, 4101, 4102 & 5122

Upright 312T

Upright Model	A	B	C	
315	2.98"	2.56"	15 GA	
314	3"	2.71"	14 GA	
312 312T	3.06"		12 GA	
4101	3.97"		13 GA	
4102	4.01"		12 GA	
5122	4.8"		12 GA	

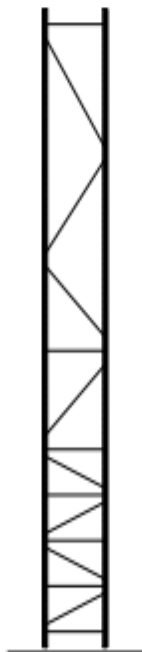

312 – 58122

Frames feature (4) 24" vertical lower panels

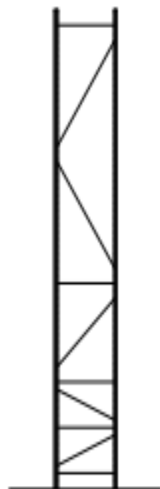

315 (156"-192") – 314

Frames feature (2) 24" vertical lower panels

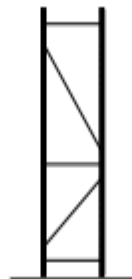

315 (60"-154")

Frames feature 52" vertical lower panel

BRACING DISTRIBUTION

Standard bracing distribution for bolted frames varies by model according to the required height of the frame; however, the following guidelines may be applied.

For more details, contact your Interlake Mecalux representative.

STANDARD FOOT PLATES AND SHIMS

FOOT PLATES

Frames are secured to the ground using foot plates that are bolted to the bottom of the posts. Foot plates are anchored to the floor using Anchor Bolt MSA W1/2 X 4 1/4".

J and M foot plates are commonly used in seismic areas or in locations with less than desired floor structures.

If a different foot plate is used, the number of anchors will be determined by the calculation. Additional anchors provided by special request.

All foot plates come with holes that allow the frame to be bolted into the floor. Each hole is 5/8" in diameter.

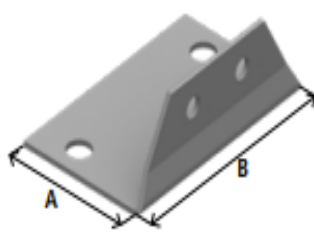

Foot Plate U

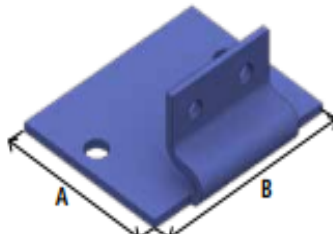

Foot Plate 3P / 4100 / 5122

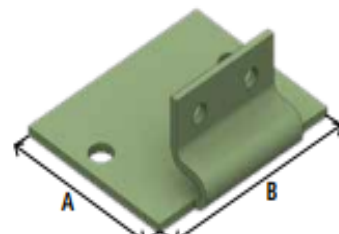

Bolted Foot Plates						
Foot Plate	Frame	Part Number	Finish	A	B	Gauge
U 077/080	3B15	T0052501	Galvanized	3 25/64"	5 15/64"	11 (0.119")
U3P	3B14 3B12 3B12T	T0200868	Blue	4 11/16"	5 3/32"	6 (0.194")
		T0200869	Green			
U100	4B101 4B102	T0029078	Blue			
		T0103702	Green			
U120	5B122	T0029079	Blue		6 57/64"	
		T0112071	Green			

Foot plates should be attached to the posts using 2 bolts W3/8X1" D933 G5 B TE1A (T0029082) with 2 Washer Cup-Foot plate TD U (T0043168)

SHIMS

Shims are metal plates with the same dimensions as foot plates. They help to level out racks that are placed on irregular surfaces. There are different shims for each type of foot plate.

Two thicknesses are available to enable accurate leveling. When ordering shims, the following guidelines should be kept in mind:

Gauge 11 (0.120")

- 2 x frame quantity
- 1 x post quantity
- (if individual posts are quoted)

Gauge 18 (0.048")

- 1 x frame quantity
- 1 x post quantity
- (if individual posts are quoted)

Gauge 13 shims are available upon request.

- Available in a standard galvanized finish.

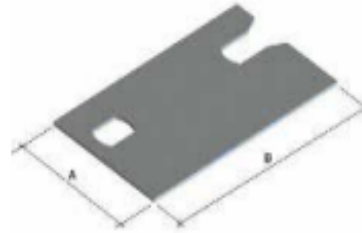

Shim Model	A	B
U 077, U 080	3 9/64"	5 15/64"

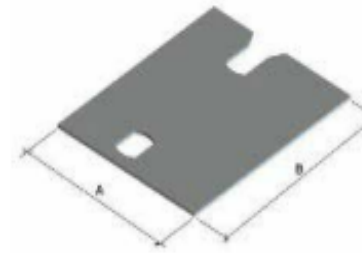

Shim Model	A	B
U 3P	4 11/32"	5 3/32"
U 100		6 7/64"
U 120		6 57/64"

Bolted Shims				
Shim	Frame	Part Number	Gauge	Finish
U 077 U 080	315	T0053005	G11	Galvanized
		T0053004	G13	
		T0053003	G18	
U 3P	314 312 312T	T0200872	G11	
		T0200871	G13	
		T0200870	G18	
U 100	4B101 4B102	T0032355	G11	
		T0032354	G13	
		T0032353	G18	
U 120	5B122	T0032358	G11	
		T0032357	G13	
		T0032356	G18	

HEAVY-DUTY FOOT PLATES

In special instances, bolted frames require heavy-duty foot plates. In those situations, J and M foot plates and shims are used. Foot plates are available in a standard blue or green finish and the shims have a galvanized finish.

Contact your Interlake Mecalux representative for more information.

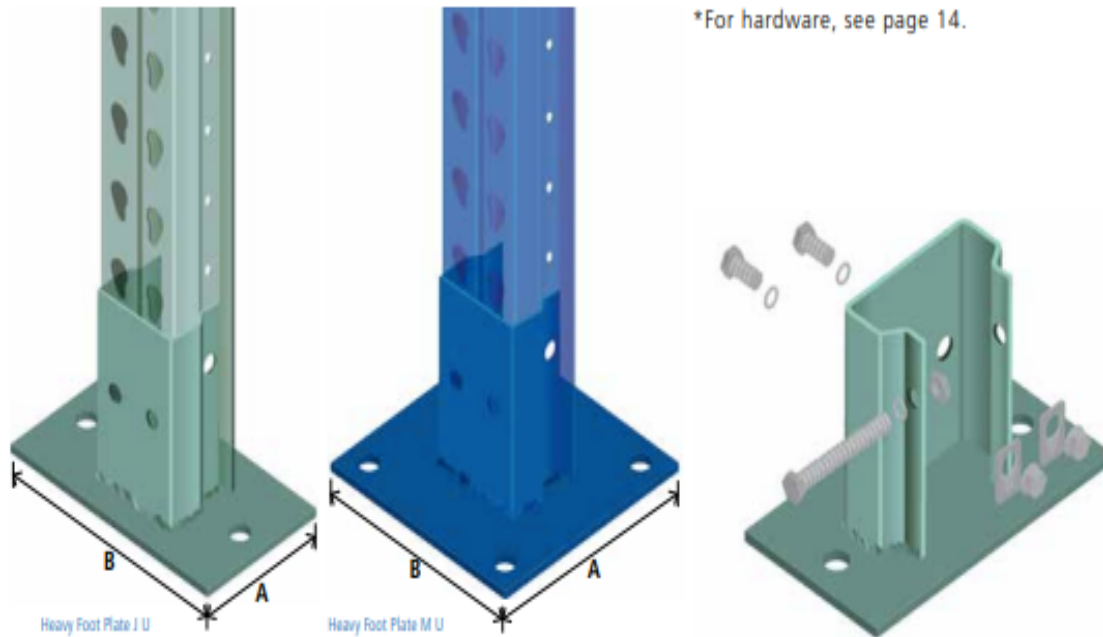

Heavy Foot Plate M U & J U Options					
Heavy Foot Plate	Frame	Part Number	A	B	Thickness
J U3P	3B14_BJ 3B12_BJ 3B12T_BJ	T0200874 (blue color) T0200875 (green color)	5.118"	7.283"	0.394"
J U100	4B101_BJ 4B102_BJ	T0200800 (blue color) T0200818 (green color)		9"	
J U120	5B122_BJ	T0200801 (blue color) T0200819 (green color)			
M U3P	3B14_BM 3B12_BM 3B12T_BM	T0200876 (blue color) T0200877 (green color)	7.874"	7.874"	
M U100	4B101_BM 4B102_BM	T0200803 (blue color) T0200821 (green color)			
M U120	5B122_BM	T0200804 (blue color) T0200822 (green color)			

HEAVY-DUTY FOOT PLATES F J U & F M U

Heavy-duty F (flush) foot plates will only be used when the anchors cannot interfere with the aisle and/or cannot be placed out of the frame limits.

Heavy-duty foot plates ship with:

2 x Washer Cup (T0043168)

2 x Bolts W3/8 x 1" D933 G5 B TE1A (T0029082)

1 x Bolt W5/16 x 2-3/4" (T0029098) x 3-3/4" (T0203315) x 4-3/4" (T0203317) D931 G5 B TE1A

- Available in a standard blue or green finish.
- The frame is mounted flush to the front of the foot plate.
- They will be quoted by components and **only** by request.

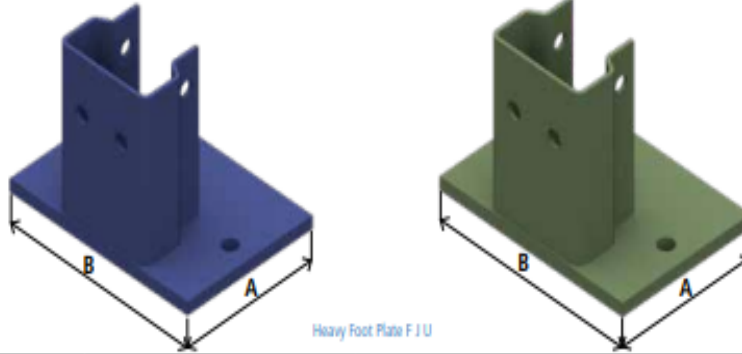

Heavy Foot Plate F J U & F M U Options				
Heavy Foot Plate	Part Number	A	B	Thickness
F J U3P	T0203269 (blue color) T0203270 (green color)	5.118"	7.283"	0.394"
F J U100	T0203277 (blue color) T0203278 (green color)		9"	
F J U120	T0203281 (blue color) T0203282 (green color)			
F M U3P	T0203271 (blue color) T0203272 (green color)	7.874"	7.874"	0.394"
F M U100	T0203279 (blue color) T0203280 (green color)			
F M U120	T0203283 (blue color) T0203284 (green color)			

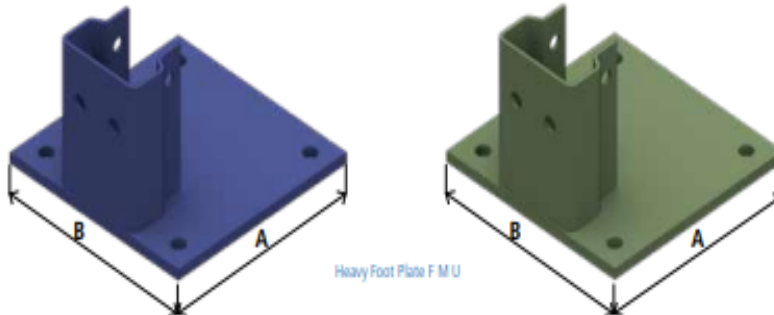

HEAVY-DUTY FOOT PLATE SHIMS

Heavy-duty foot plate shims will be the same dimensions as their corresponding foot plates.

Two thicknesses are available to enable accurate leveling. When ordering shims, the following guidelines should be kept in mind:

Gauge 11 (0.120")

- 2 x frame quantity
- 1 x post quantity
- (if individual posts are quoted)

Gauge 16 (0.060")

Only available upon request.

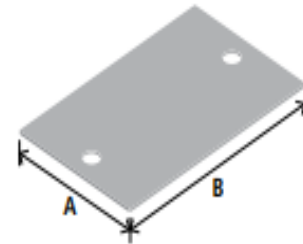

Shim for Heavy Foot Plate J U

Shim Model	A	B
U 3P	5.118"	7.283"
U 100		
U 120		9"

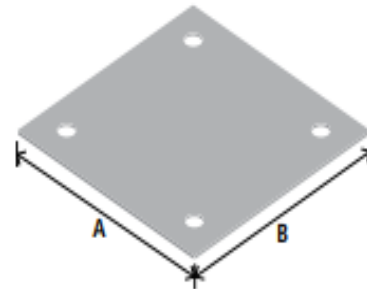

Shim for Heavy Foot Plate M U

A	B
7.874"	7.874"

Shim Options for Heavy Foot Plate M U & J U				
Post Model	Part Number	A	B	Gauge
U 3P, U 100	T0200807	5.118"	7.283"	G11
	T0200805			G16
U 120	T0200808	5.118"	9"	G11
	T0200806			G16
8x8 ("M")	T0200824	7.874"	7.874"	G11
	T0200823			G16

SHIMMING

In installations with very uneven floors, the maximum shim height should not exceed 1-15/16". If the unevenness of the floor exceeds this dimension, the post is to be repositioned vertically using a hole punch as a reference for the distance ($\pm 2"$). Note that shimming may require longer anchors to maintain minimum embedment.

Shimming $\geq \frac{25}{32}" = 2$ Anchor Bolts

Shimming $\geq \frac{25}{32}" = 2$ Anchor Bolts

Shimming $\geq \frac{25}{32}" = 2$ Anchor Bolts

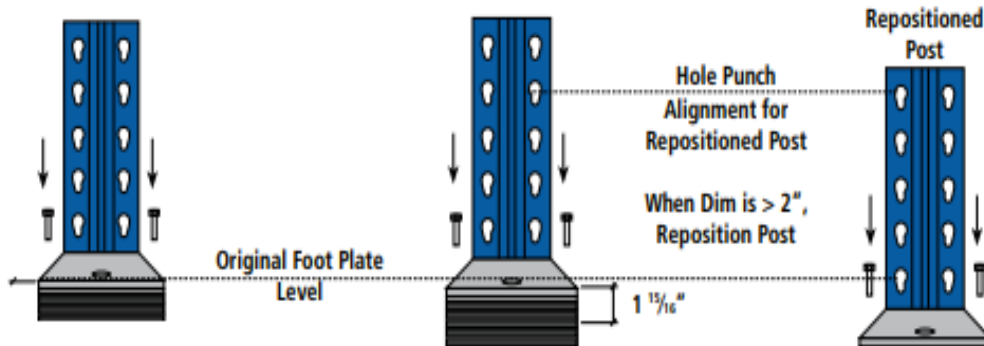

ASSEMBLING SELECTIVE RACKING

In order to assemble a Selective Rack frame the following points must be taken into consideration:

1. **Foot plates U (A)** should be fixed to the uprights (**B**) using two Bolts W3/8X 1" D933 G5 B TE1A (**C**) and two foot plate washers cups (**D**), bearing in mind that the narrow end of the teardrop shaped holes should face downwards.

On the other hand, if **foot plates J U, F J U, M U or F M U (E)** are needed, they should be fixed to the uprights (**B**) using two Bolts W 3/8"x1" D933 G5 B TE1A (**C**), two foot plate washer cups (**D**) and one bolt W5/16X... D931 G5 B TE1A –according to the upright model- (**F**), bearing in mind that the narrow end of the teardrop shaped holes should face downwards.

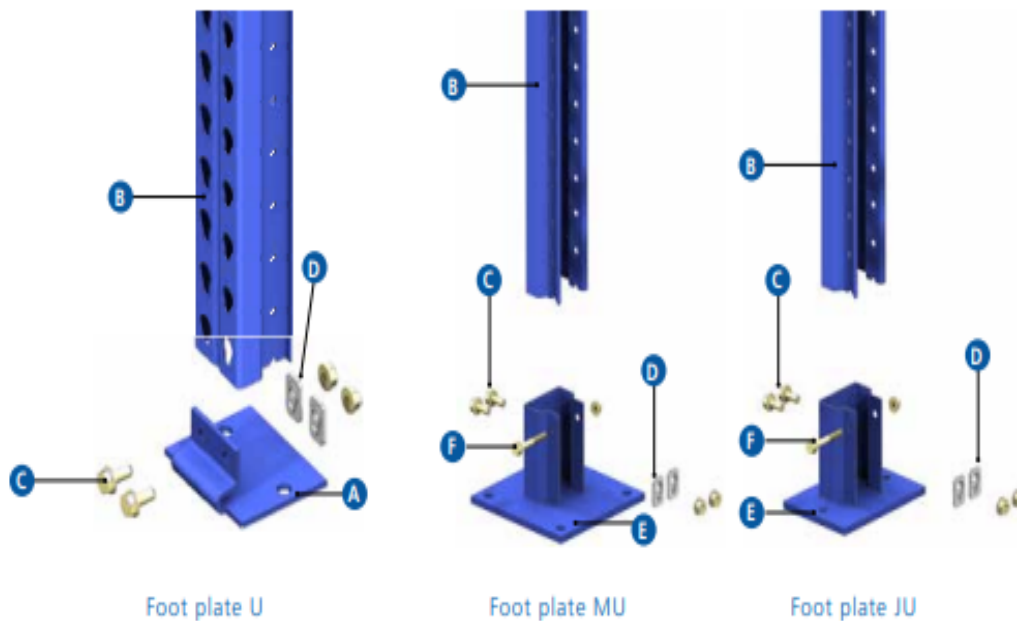

2. Verify the number of diagonal (**G**), horizontal struts (**H**), and bolts needed. The first horizontal strut (**H**) should be placed 6" or 8" from the lower using the appropriate bolts W 5/16 (**I**).

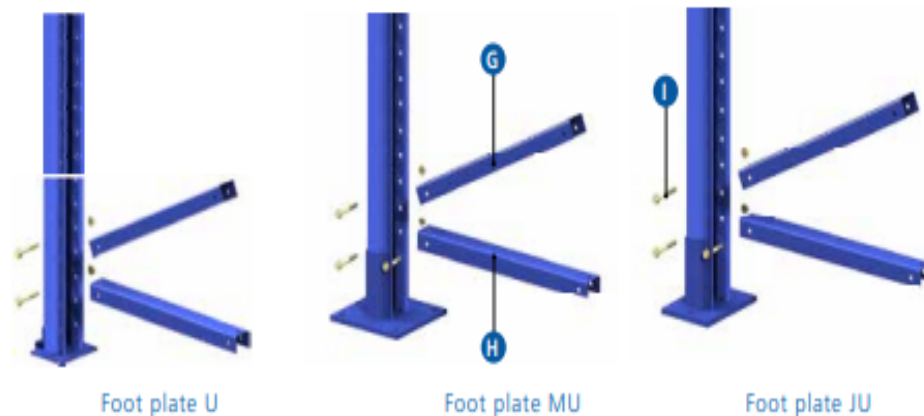

STRUTS

Bolted struts are "C" shaped profiles that are bolted to the posts of a frame. When struts are placed diagonally, they are referred to as diagonals. When placed horizontally, they are referred to as horizontals.

- Available in a standard blue or green finish.

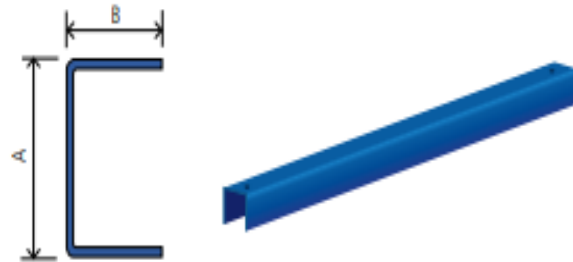

Bolted Struts					
Model	Frame Post Model	Gauge	Hardware	A	B
C456	315, 314, 312, 312T	16 ga	(2) BOLTS W5/16" x 2 3/8" D931 G5 B TE1A (T0201564)	1 25/32"	1 3/8"
C715	101, 102		(2) BOLTS W5/16 x 3 7/16" D931 G5 B TE1A (T0029094)	2 3/4"	
C915	122		(2) BOLTS W5/16 x 4 7/32" D931 G5 B TE1A (T0029095)	3 17/32"	

WASHER CUP - FOOT PLATE TD U (T0043168)

Rectangular plates of 1-9/16" x 15/16" x 1/8" thick with a hole. They are used to help prevent the bolt, which fixes the foot plate to the post, from moving.

- Available in a galvanized finish.

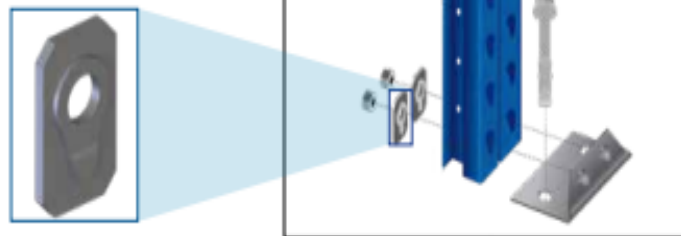

BOLTED REINFORCEMENT BRACKETS

Reinforced frames increase their capacity when both columns are reinforced up to just above certain beam levels (usually required in seismic areas). This first-of-its-kind, entirely bolted solution eliminates the need for welding on reinforced posts by using bolted reinforcement brackets.

- Each post can only be reinforced with the same model of post.
- The required distance between each bolted reinforcement bracket is 24".
- The Top Reinforcement Bracket (4 holes) should only be used at the top of the reinforcement.
- The height of the reinforced post is to be the next even feet multiple from the height needed for the reinforcement (e.g. 116" post rounds up to 10').
- A bracket that interferes with a beam level should be moved, and the rest of the brackets should be adjusted to maintain a maximum spacing of 24".
- The foot plate will have to be a bolted seismic.



TOP REINFORCEMENT BRACKET

Has four holes and will always be at the top of the reinforcement post.

U0201014 REINF.BRACKETTOP U - Galvanized Finish



STANDARD REINFORCEMENT BRACKET

Has two holes and will be placed every 24" on the reinforcement post.

U0201013 REINF.BRACKET STD U - Galvanized Finish

SEISMIC FOOT PLATE

Whenever a frame is reinforced, a seismic foot plate will be added automatically.

U0200731 Seismic foot plate U3 - CAT Blue Finish
 U0200732 Seismic foot plate U3 I02 - Vista Green Finish
 U0200668 Seismic foot plate U100 - CAT Blue Finish
 U0200665 Seismic foot plate U100 I02 - Vista Green Finish
 U0200669 Seismic foot plate U120 - CAT Blue Finish
 U0200666 Seismic foot plate U120 I02 - Vista Green Finish



REINFORCED FOOT PLATE WITH 2 HOLES

The standard codes are:

Family	Uprights	Part Number	Description
U 3P	315	U0200729	Heavy Foot plate R 1T U 3P
	314		
	312		
	312T		
U100	4101	U0200710	Heavy Foot plate 1T U 100
	4102		
U120	5122	U0200712	Heavy Foot plate R 1T U 120

The hardware needed to fix the foot plates to the post is described on the next table:

Upright Family	Bolts to be used	Part Number
U 3P	2 BOLT W5/16X3 3/4" D931 G5 B TE1A	T0203315
U100	2 BOLT W5/16X4 3/4" D931 G5 B TE1A	T0203317
U120	2 BOLT W5/16X5 5/8" D931 G5 B TE1A	T0203318

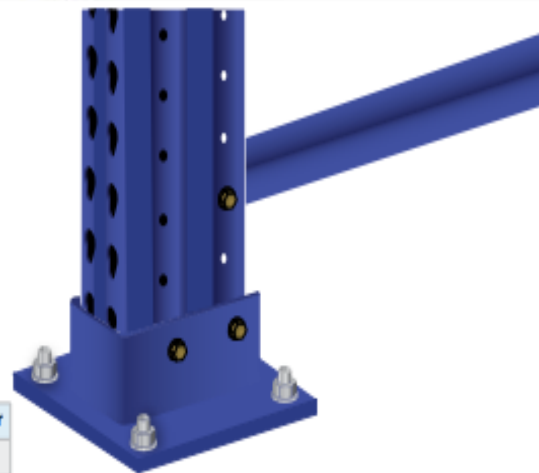

ADDITIONAL POST

It is possible to use an additional post to optimize the distribution of the frames on a Push Back application.

For Push Back systems, depending on the number of pallets in deep and according to the standard distribution, there can be a post in the middle or at the end of the rack. Please see the picture below:

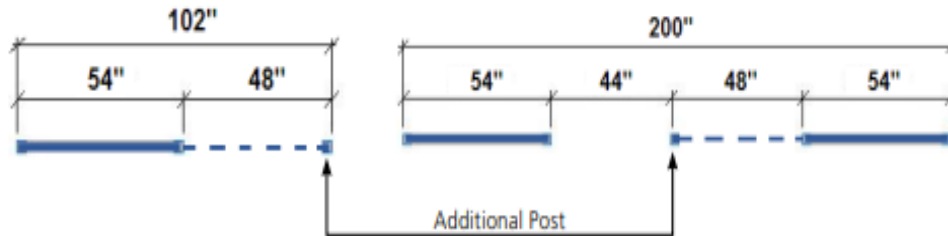

The single post is attached to one of the nearest frame with bracings and front frame brackets.

The general rule to define the number of bracing struts is that the unattached upright must be joined by diagonals to the frame as close as possible to all frame junctions where there is a diagonal or horizontal, except for the first horizontal closest to the floor.

See below:

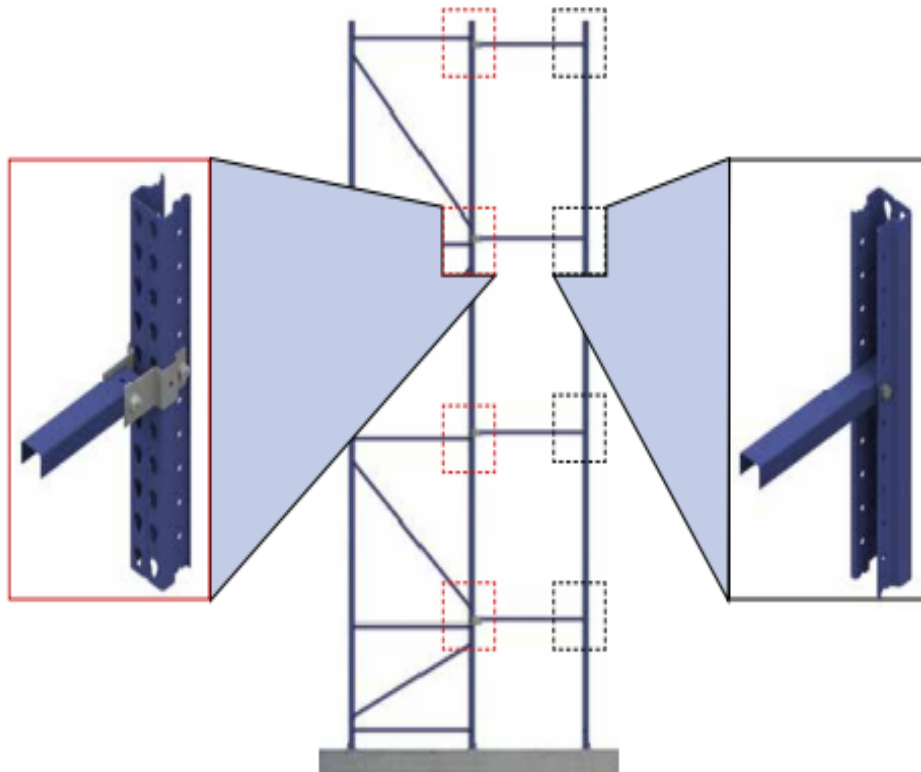

FIXING FRAME CLIPS

In instances where frames are more than 40" apart, fixing frame clips are utilized to tie frames together. These clips bolt onto the column and use a strut that is bolted in place. The size of the frame determines the size of the strut that is used. **Contact your Interlake Mecalux representative for more information.**

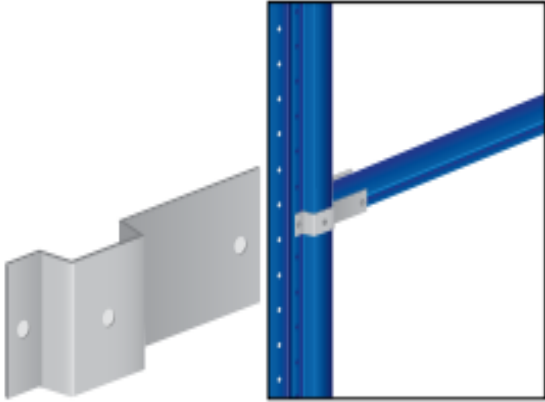

Considering the most common 40" X 48" GMA pallets, the following distributions have been standardized depending on the number of pallets deep:

2 pallets deep:

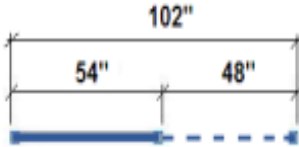

3 pallets deep:

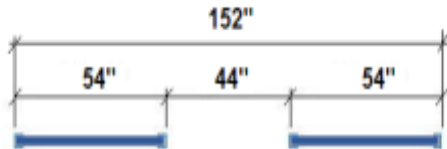

4 pallets deep:

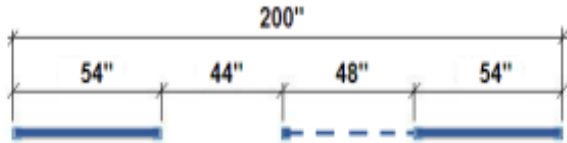

5 pallets deep:

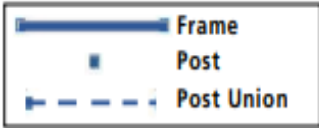
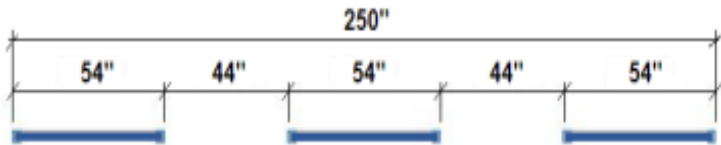

ASSEMBLING ADDITIONAL POST

The additional post (A) should be joined to the frames (B) using sets of 1 diagonal (C) and 2 U96 Frame Front Brackets (D).

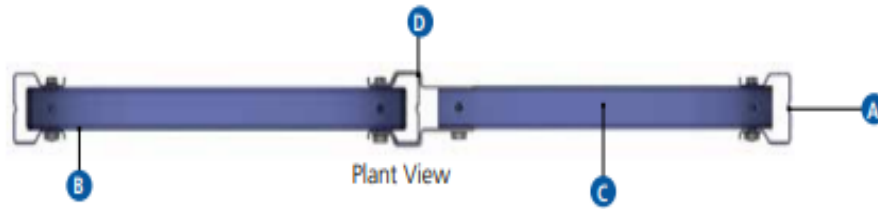

A: Additional post

C: Diagonals

B: Frames

D: U96 Frame Front Brackets

The hardware needed in each case depends on the support family used, as shown in the next picture:

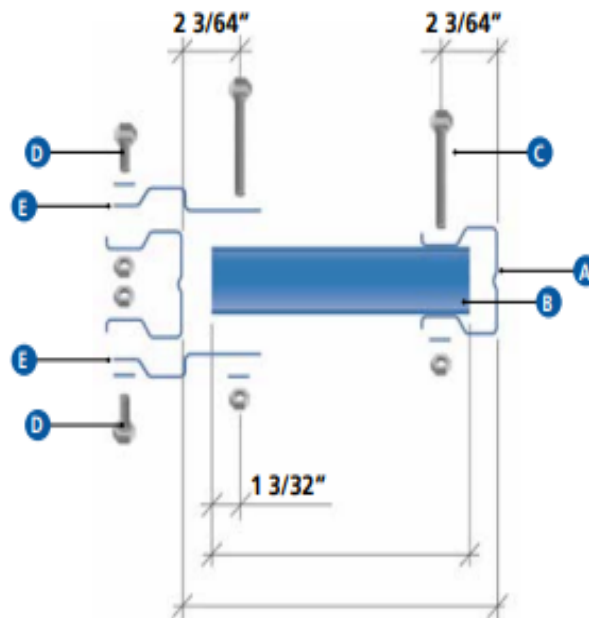

A: Additional post

C-D: Bolts

B: Diagonal U

E: Frame Front Brackets U96

Support Family	A	B	C	D	E
	Post	Diagonals U (Distance B)	Bolts	Bolts	Frame Front Brackets U96
3P	315 / 314 / 312 / 312T	1 Model C. 456	W5/16X2 3/8" D931 G5 B TE1A 2 x (Part Number T0201564)	W 5/16 X 3/4" D933 G5 B TE1A 2 x (Part Number T0032927)	2 x (Part Number T0032409)
U100	101 / 102	1 Model C. 715	W 5/16 X 3 17/32" D931 G5 B TE1A 2 x (Part Number T0029099)		
U120	122	1 Model C. 915	W 5/16 X 4 1/4" D931 G5 B T2A 2 x (Part Number T0032932)		

a= Distance between face of the post

b= Length of diagonal

$$b = a - 1 \frac{31}{32}$$

BEAMS

These are the horizontal elements of the racks that support the Push Back system. They also work as stiffener elements in the down-aisle direction of the system.

They are available in different sizes and have welded end plates at each end, which slot into the teardrop shaped holes of the frames. Two safety pin locks secure the beam to the frame in case of uplift. These safety pins are included with each end plate.

The size of this end plate varies according to the different beam models.



The beam model, profile and end plate relationship is shown on the next table:

End plate	F3M				F4M	F5M
Profile	C3X3.5	C3X4.1	C4X4.5	C4X5.4	C5X6.7	C6X8.2
Model	335	345	435	455	565	685

Beams that are part of the same bay are placed at different heights, creating a slope and allowing the carts to slide back into the rails. These rails are fixed to the beams using pre-drilled holes.

There are 2 different beam types:

- Front beams
- Interior / rear beams

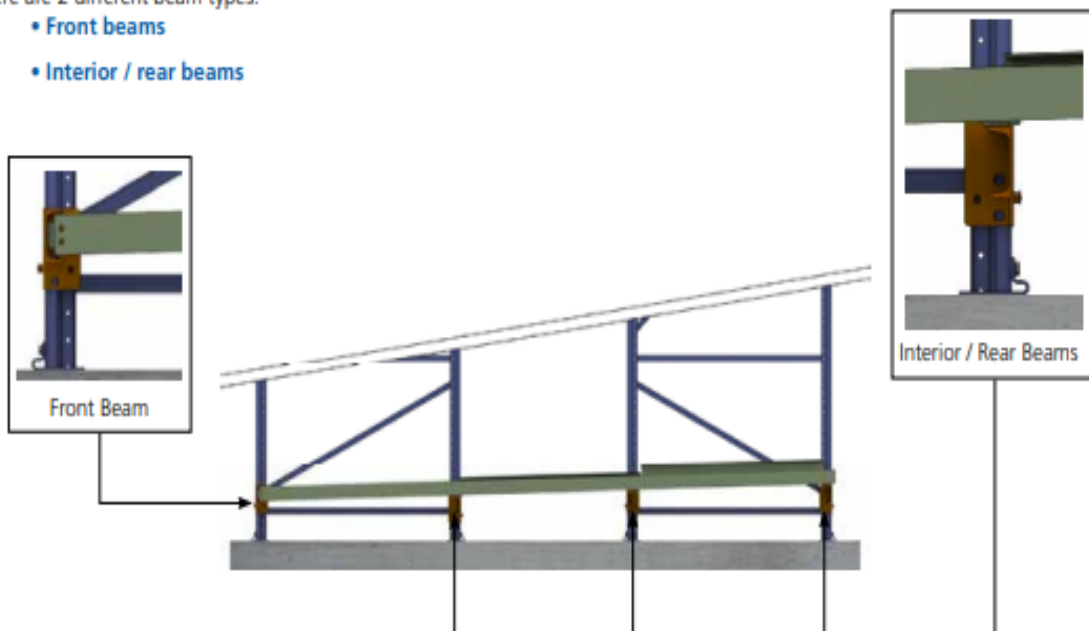

FRONT BEAMS

These beams support the Push Back rails. For this reason, they need a minimum height of 4" (model 435 & 455) depending on the load. Rails are bolted to the beams on the beam's "C" channel web. Standard finish: orange

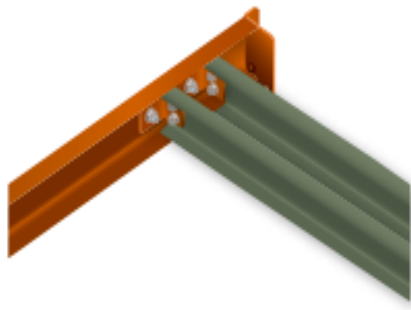

Interior view of the rack

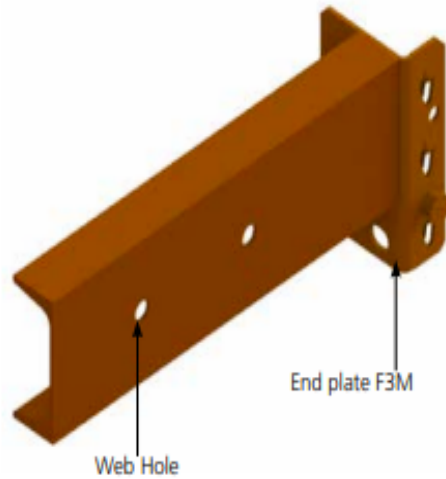

Web Hole

End plate F3M

Example of standard product description:

BEAM PB IK435W, F3M, 4H 48"

Profile model: 435 or 565 ———— Length
W: 4 web holes ———— Number of web holes
U: 8 web holes
T: 12 web holes

INTERIOR/REAR BEAMS

These beams are used to hold the rails of the Push Back. The bolted connections use the holes on the profile's top flange. Standard finish: orange

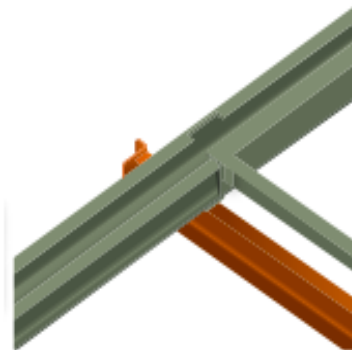

Push Back rail and interior/rear beam assembly

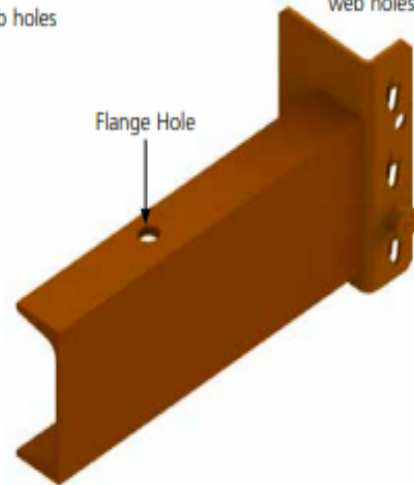

Flange Hole

Example of standard product description:

BEAM PB IK565P, F4M, 4H 96"

Profile model: 335, 435, 455, 565 or 685 ———— Length
N: 2 flange holes ———— 2, 4 or 6 flange holes
P: 4 flange holes
S: 6 flange holes
F3M: Connector with 3 tabs
F4M: Connector with 4 tabs
F5M: Connector with 5 tabs

Taking into account that the pallet width is 40" and the possibility of using 1, 2 or 3 wide pallets per bay, the following beam lengths have been standardized.

Other lengths can be ordered as VF.

Number of pallets per bay	Beam length
1	48"
2	96"
3	144"

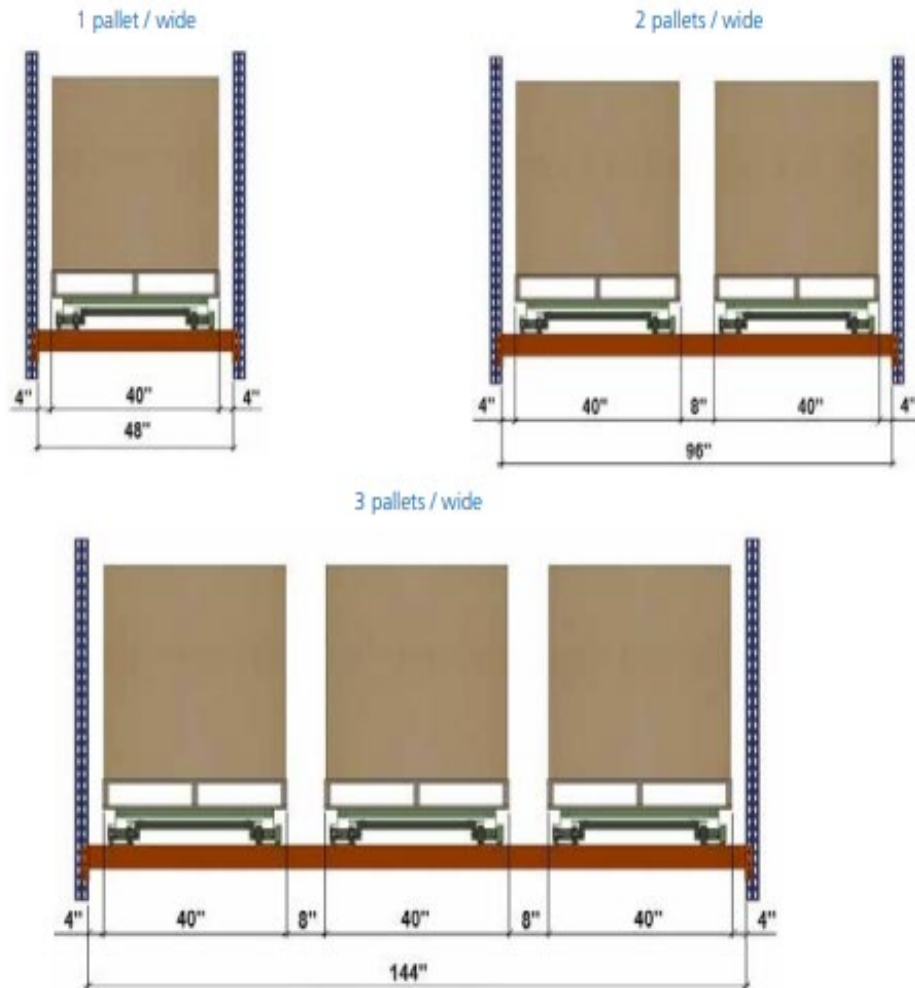

To ensure the system works properly, the slope must be 5/16 per foot (12") or approximately 1.5°. In order to use a correct slope, the following beam droops have been standardized with each beam model. Dimensions are from end plate's top to beams' top.

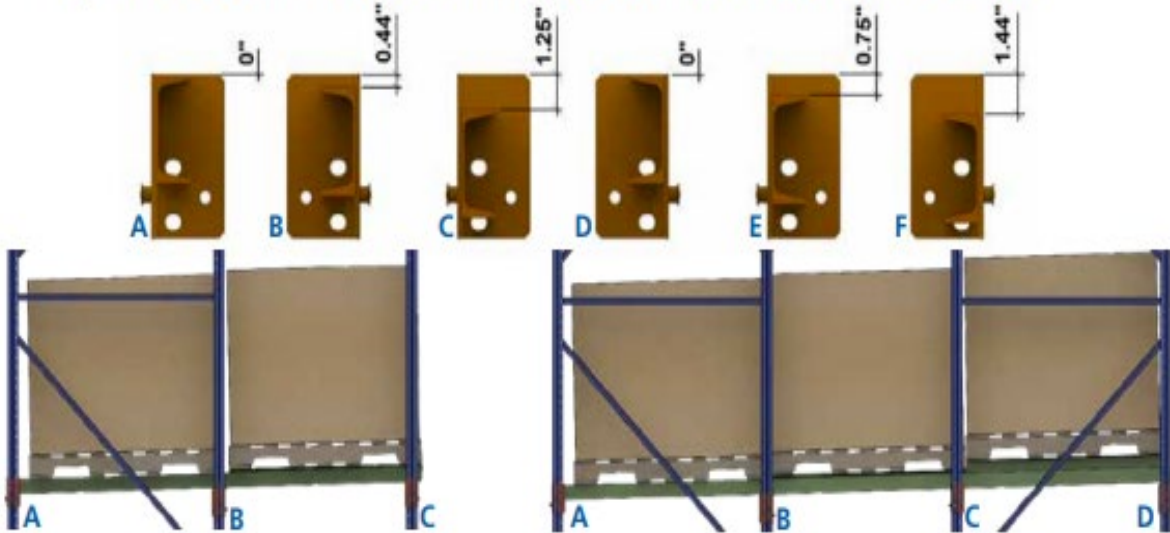

2 Deep Drop Disposition			
Pallet Depth	A	B	C
48"	0"	0.44"	1.250"

3 Deep Drop Disposition				
Pallet Depth	A	B	C	D
48"	0"	0.44"	1.250"	0"

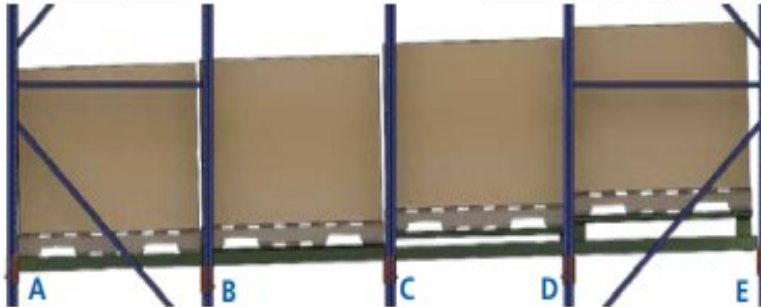

4 Deep Drop Disposition					
Pallet Depth	A	B	C	D	E
48"	0"	0.44"	1.250"	0"	0.750"



5 Deep Drop Disposition						
Pallet Depth	A	B	C	D	E	F
48"	0"	0.44"	1.250"	0"	0.750"	1.44"

RACK DIMENSIONS / DESIGN

The minimum height for the first beam depends on the type of foot plate and the beam end plate.

HEAVY DUTY FOOT PLATE

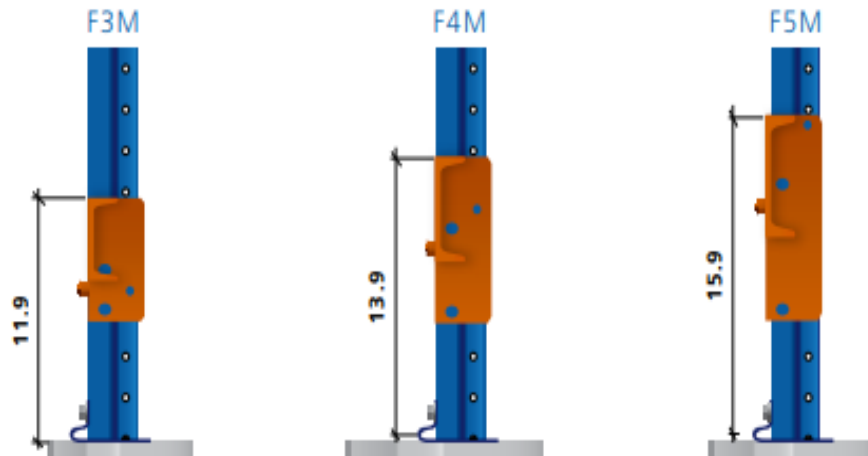

FOOT PLATE M / J

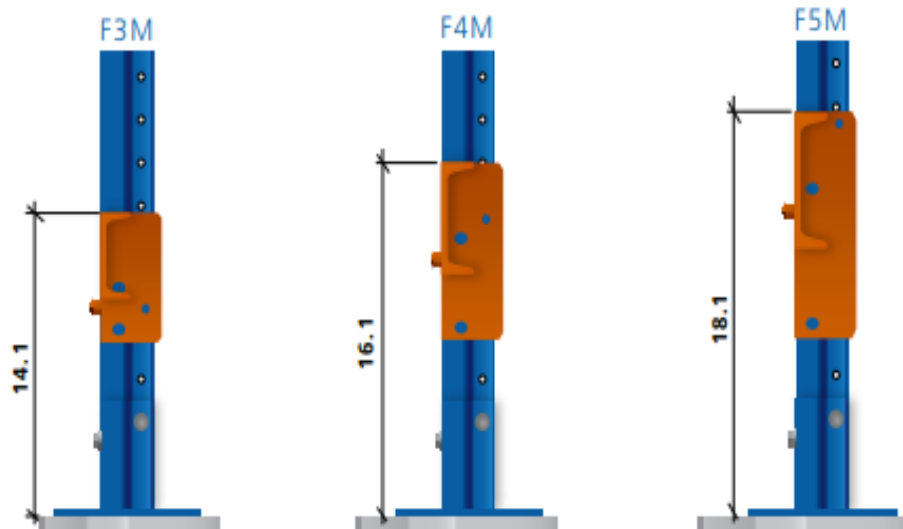

FOOT PLATE R2T

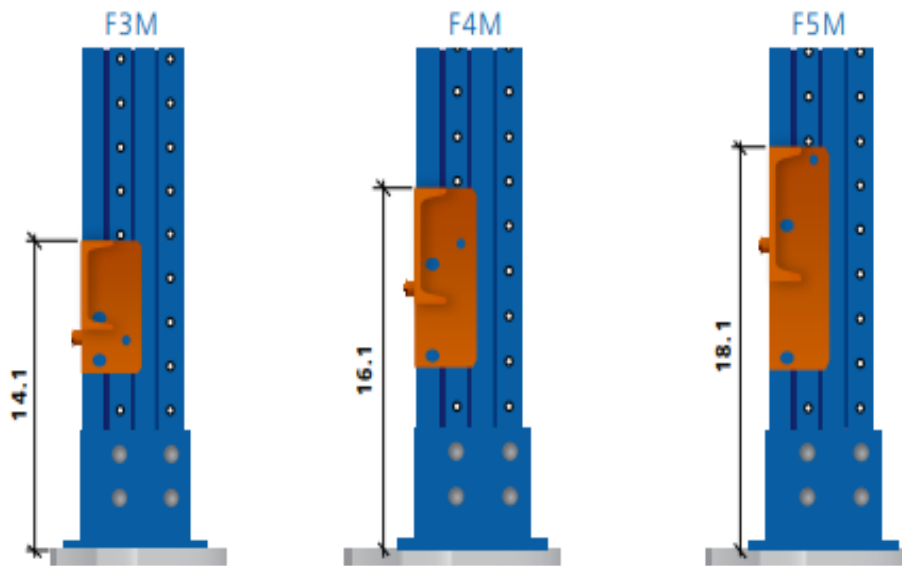

FOOT PLATE R1T

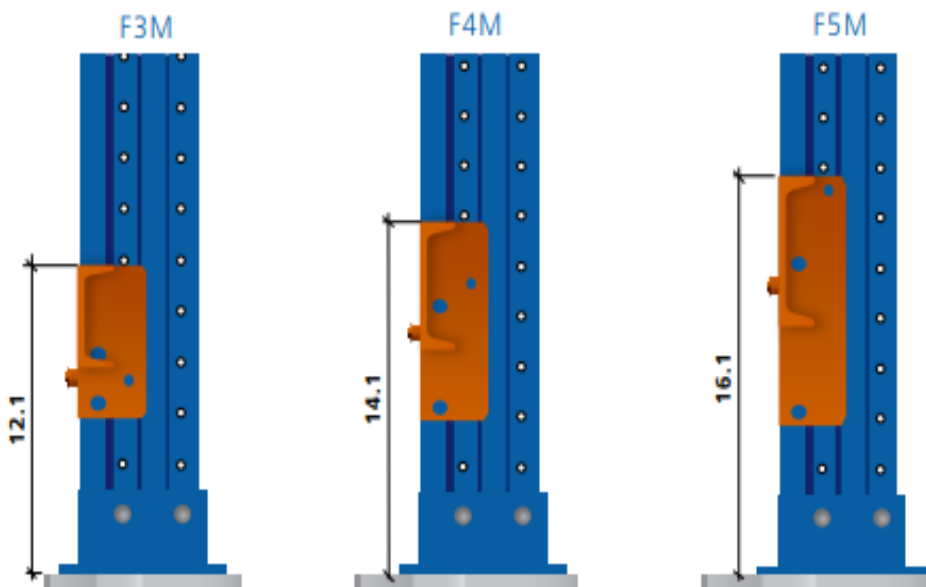

The beam level height will be designed according to:

- **Load height.** Total height of the pallet + load height.
- **Minimum clearance of 3".** Minimum clearance between loads and any other element of the rack.

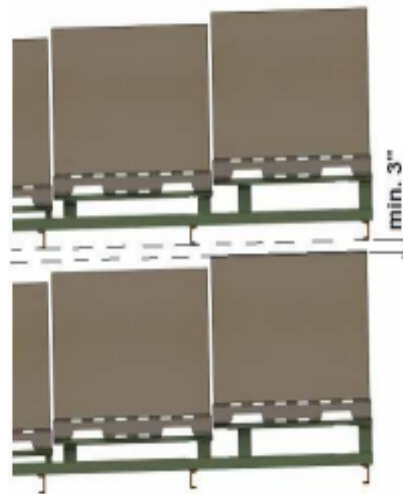

- **Number of pallets in depth:** Depending on the number of pallets in depth, the push back system has different cart configurations (hc) and therefore a different height from the first load to the last one.

Pallets deep	hc
2	0.15"
3	2.15"
4	4.77"
5	7.46"

hq: Load height

hc: Carts' height

v: Variable height depending on beam

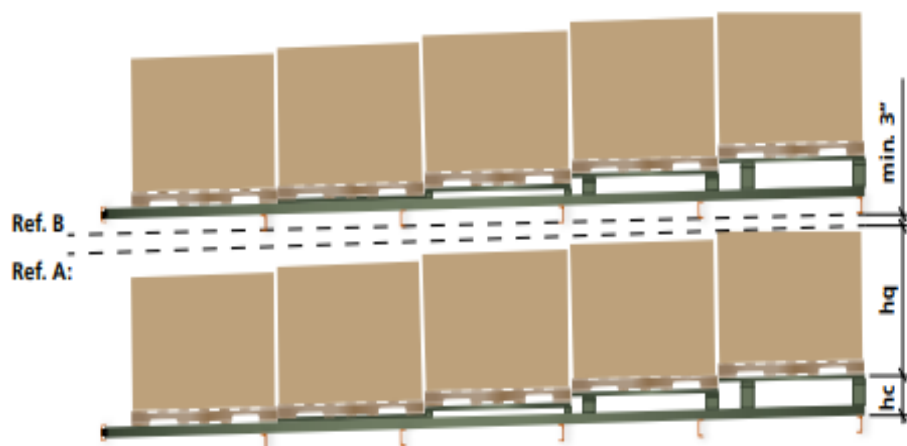
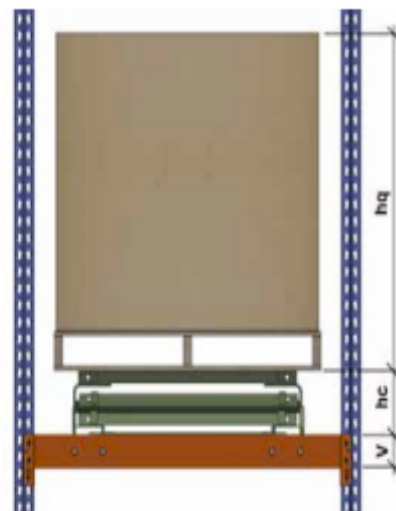

Ref. A: load height limit

Ref. B: load height limit + 3" minimum tolerance (looseness)

FRAME HEIGHT

Frame heights will be the same for the entire system, taking into account:

Height (inch) min/max:

Blue color (standard): From 4' to 39' each 2" except FR.3B15 (from 5' to 16' each 2").

Green color: From 4' to 26' each 2" except FR.3B15 (from 5' to 16' each 2").

Frame height = last level height on back side + $\frac{1}{2}$ of the load height

(Standard heights are multiples of a foot)

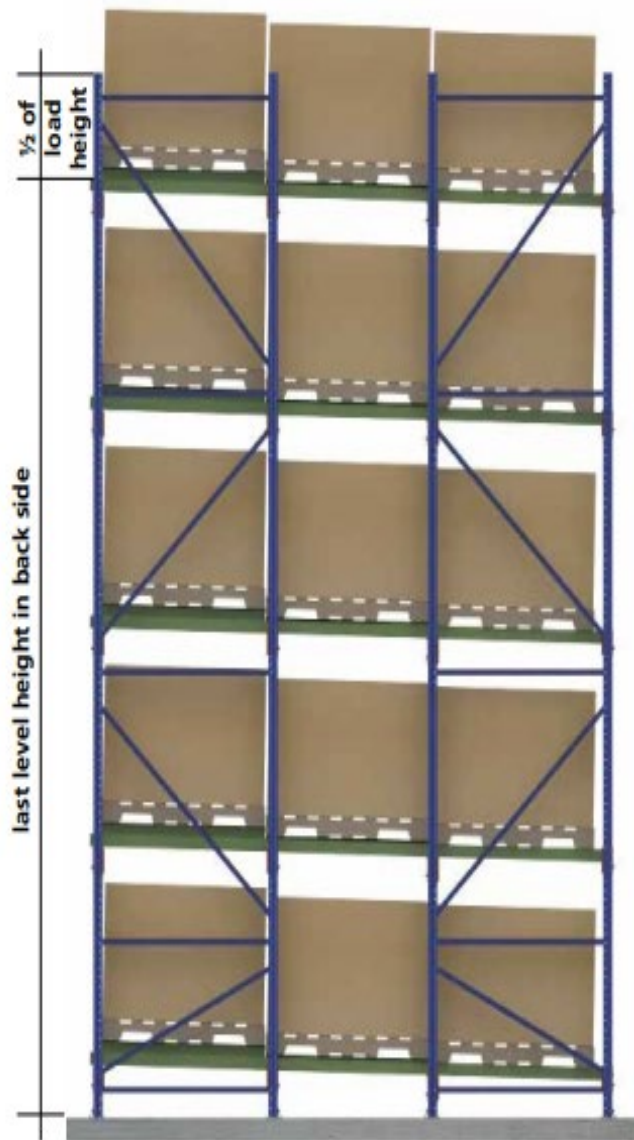

CART COMPONENTS

The Push Back system is basically composed of two lateral tracks and different carts (depending on the number of pallets in depth), which slide inside of the push back structure. Bays in Push Back systems can be up to five pallets deep. The first load in a bay is placed on the top cart (1). The next load will be loaded such that it pushes back the cart that is currently loaded in the system, until the cart beneath it has been revealed, at which point the newest load will be placed upon it (2). The process is completed as necessary (3). The carts are kept in place with rails that run the length of the bay. The last load entered in the bay will be placed on these rails.

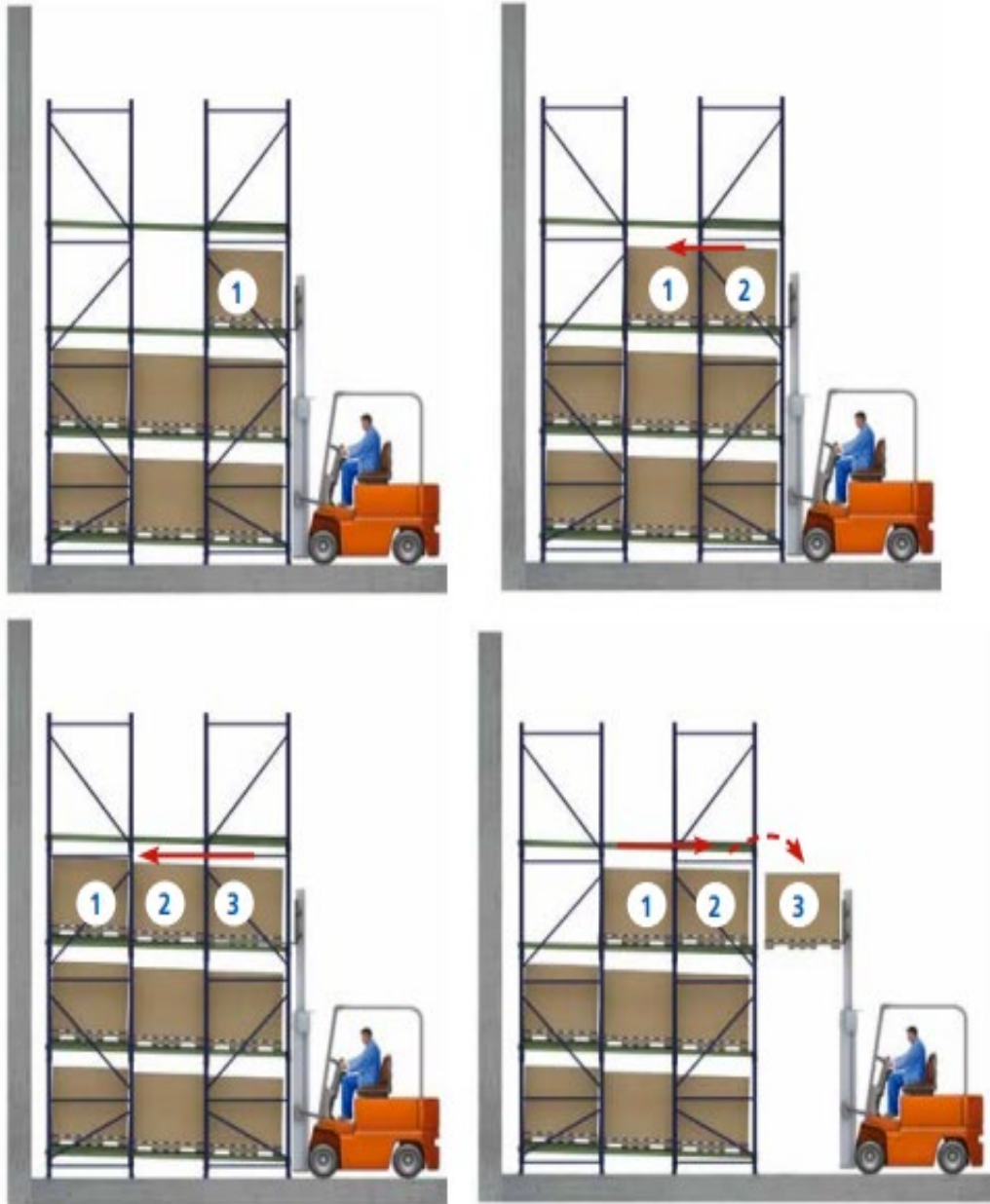

The following system configurations are available according to the number of pallets in depth.

- 2 pallets deep system

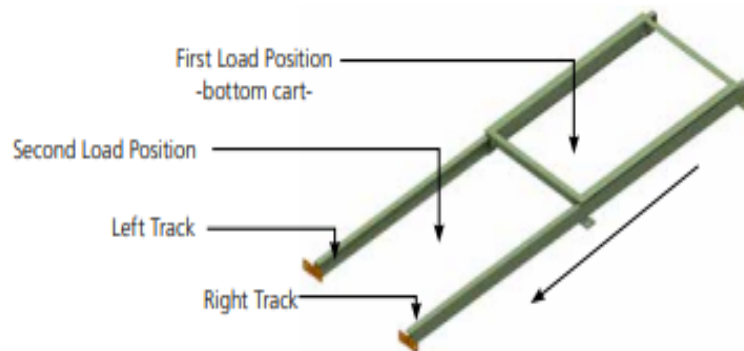

- 3 pallets deep system

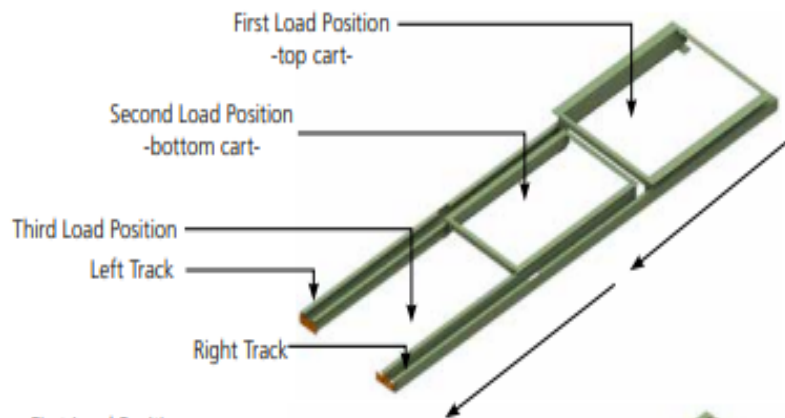

- 4 pallets deep system

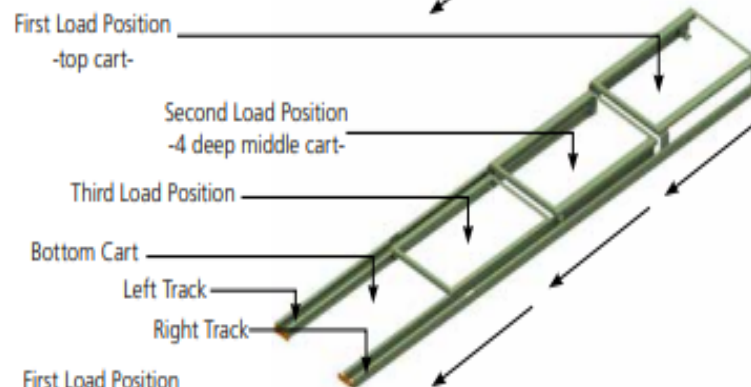

- 5 pallets deep system

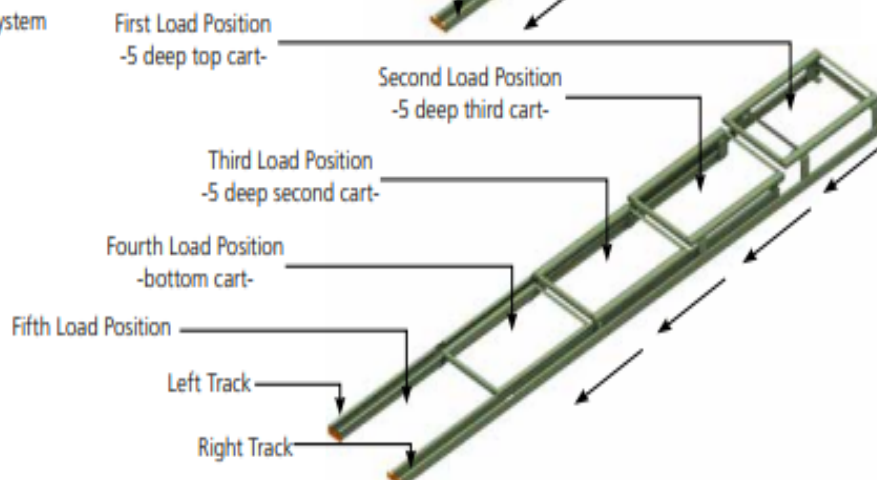

TRACK PB IJR...

Push Back rails are the elements used to hold and guide the Push Back Carts. They have been designed with C3x3.5 structural channels with welded slotted plates on their lower flanges. For 2 deep distributions, this track is formed by only one C Channel, while for 3, 4 & 5 deep distributions every lateral track 2 C Channels.

Standard finish is vista green

There are left and right tracks.

The length of these rails is defined according to the number of pallets deep in the system. See table below:

Pallets in deep	Rail length
2	$2 \times 48" + 6" = 102"$
3	$3 \times 48" + 8" = 152"$
4	$4 \times 48" + 8" = 200"$
5	$5 \times 48" + 15" = 255"$

These tracks are fixed to the top flange or C Push Back beams using the following hardware:

Front Beam	
A	3/8"-16 x 1 Bolt & Flanged Locknut
B	1/2"-13 x 1 1/2" Bolt & Flanged Locknut

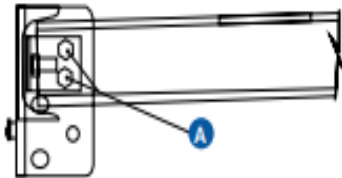

Interior Beam	
A	1/2"-13 x 1 1/2" Bolt & Flanged Locknut

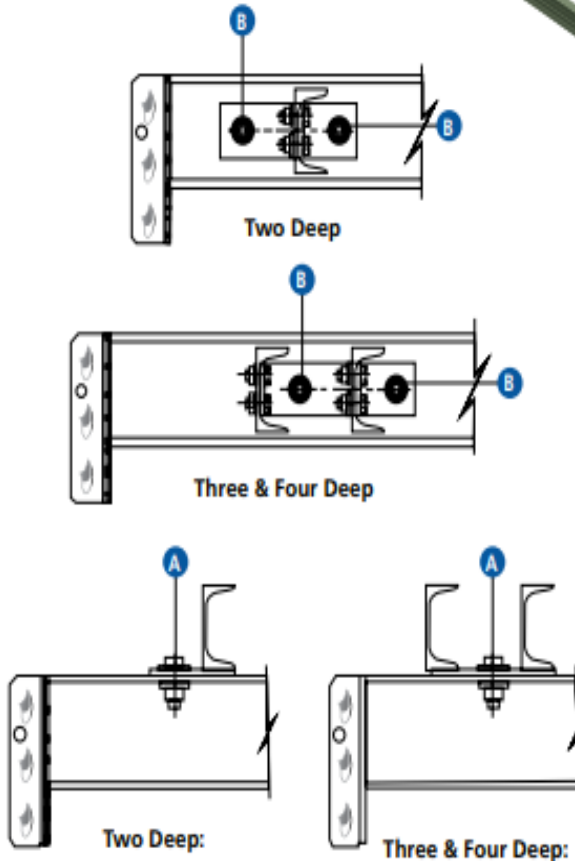

We should difference between hardware for frontal beams and hardware for interior and rear beams. Furthermore, tracks must be attached to the web holes of the Push Back's front beams using the angle front track and/or the channel front track IHALN.

ANGLE FRONT TRACK...DEEP

It is an L shaped plate that fixes the Tracks PB to the front Push Back beams.
Its standard finish is orange.

Two types have been standardized depending on the pallets in depth.

Pallets deep	Quantity and model of Angle Front Track
2	2 Angle Front Track 2 deep (Part number U0075873) 2 Angle Front Track 4 deep (Part number U0075872)
3	
4	2 Angle Front Track 4 deep (Part number U0075872)
5	



Angle Front Track 2 deep



Angle Front Track 4 deep

CHANNEL FRONT TRACK IHALN

(Part Number U0075874)

U shaped plate that fixes the double C shaped tracks to the front beam for 3, 4 and 5 deep distributions.

Its standard finish is orange.



These "C" and "U" shaped plates must be fixed to the Push Back front beams using the following hardware:

To the Tracks PB	A: 2 Bolt 3/8-16 X 1" HHC G5 Z (Part number U0074632) 2 Locknut Flange 3/8-16 Z (Part number U0074687)
To the front beams	B: 1 Bolt 1/2-13 X 1 1/2" HHC G5 Z (Part number U0074603) 1 Locknut Flange 1/2-13 Z (Part number U0074686)

The following details show how to assemble the different configurations:

-2 deep configuration assembly detail-

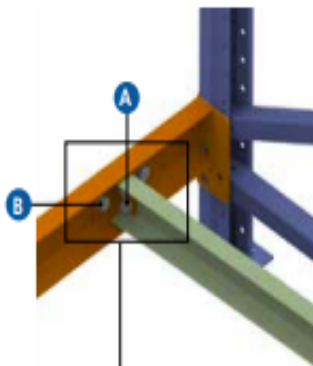

-3, 4 & 5 deep configuration assembly detail-

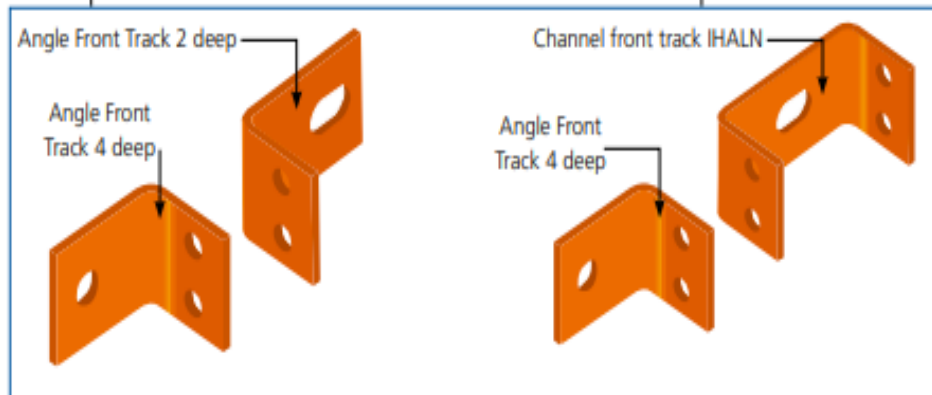
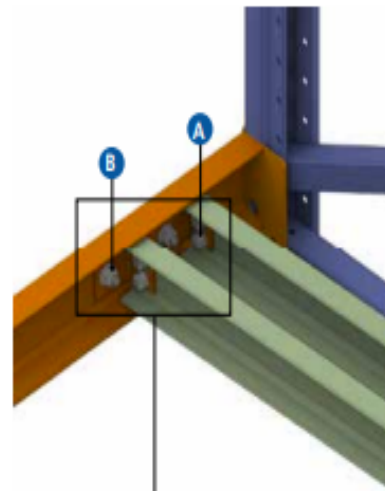

KI-CART PB...

The following KI-Cart PB... have been standardized depending on the number pallets in deep of the system.

- 2 pallets deep:

A: 1 KI-CART PB IJBC2A 40"X 48"
(Part number U0081978)

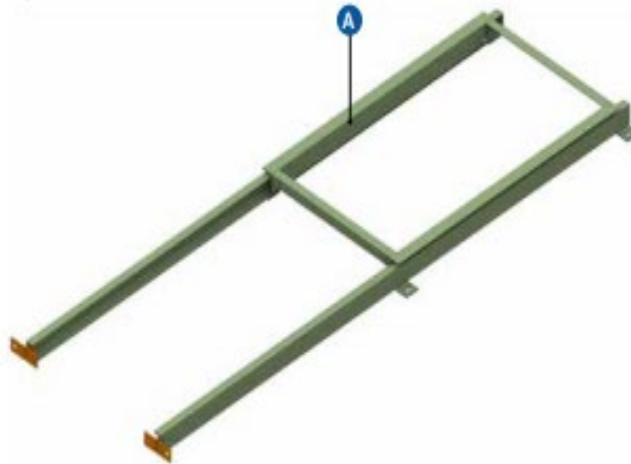

- 3 pallets deep:

A: 1 KI-CART PB IJBC2A 40"X 48"
(Part number U0081978)
B: 1 KI-CART PB IJTC3A 40"X 48"
(Part number U0082018)

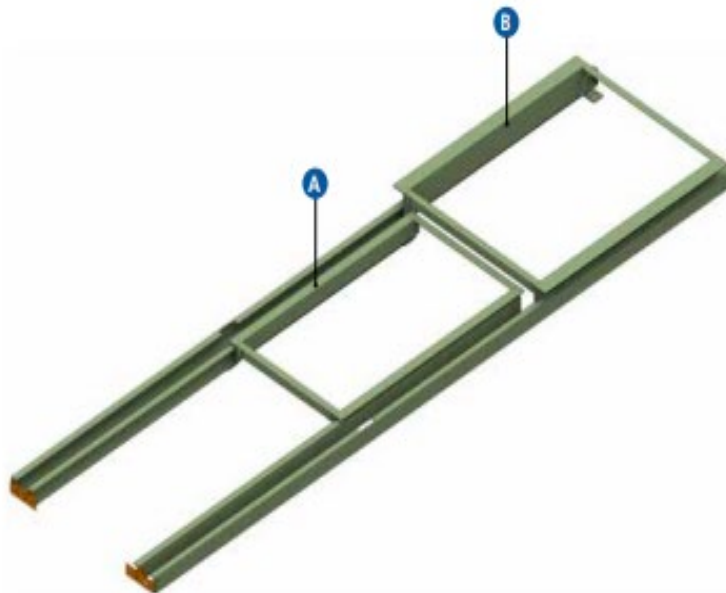

• 4 pallets deep:

- A: 1 KI-CART PB IJBC2A 40"X 48"
(Part number U0081978)
- C: 1 KI-CART PB IJMC4A 40"X 48"
(Part number U0082100)
- D: 1 KI-CART PB IJTC4A 40"X 48"
(Part number U0082057)

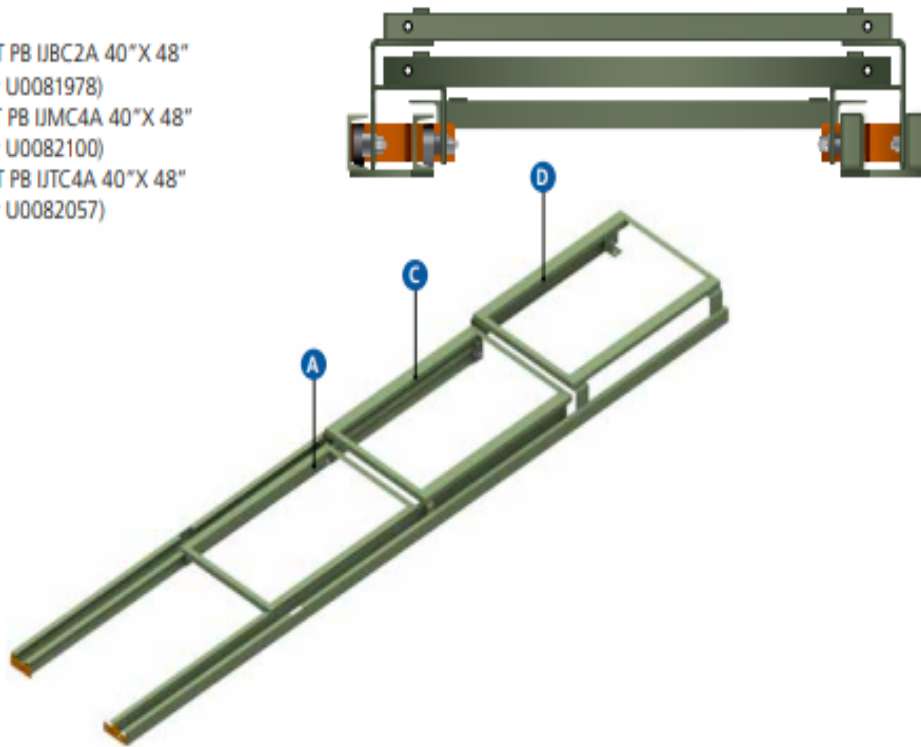

• 5 pallets deep:

- A: 1 KI-CART PB IJBC2A 40"X 48"
(Part number U0081978)
- C: 1 KI-CART PB IJMC4A 40"X 48"
(Part number U0082100)
- E: 1 KI-CART PB IJMC5A 40"X 48"
(Part number U0099766)
- F: 1 KI-CART PB IJTC5A 40"X 48"
(Part number U0099808)

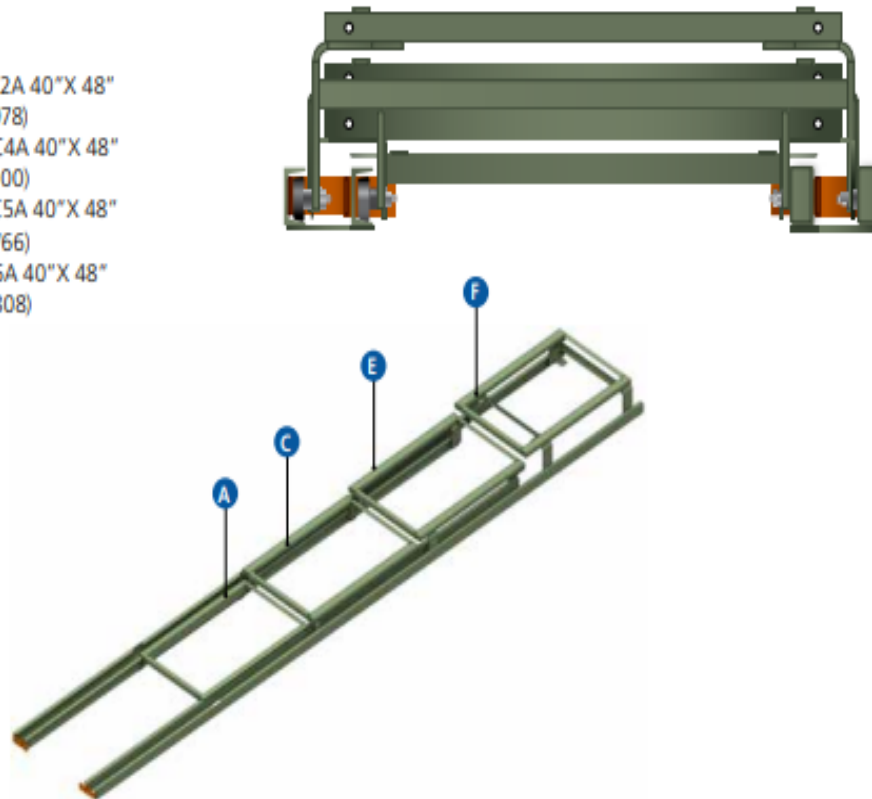

In order to make technical and commercial tasks easier setshave been standardized, They include all the components needed for each configuration.

Part Number	Description	Cart Model (included in the set)			
		Cart 1	Cart 2	Cart 3	Cart 4
U0082134	St.Push back deep 2 40"x48"	IJBC2A P.N.U0081978			
U0082158	St.Push back deep 3 40"x48"	IJBC2A P.N.U0081978	IJTC3A P.N.U0082018		
U0082176	St.Push back deep 4 40"x48"	IJBC2A P.N.U0081978	IJMC4A P.N.U0082100	IJTC4A P.N.U0082057	
U0099854	St.Push back deep 5 40"x48"	IJBC2A P.N.U0081978	IJMC4A P.N.U0082100	IJMC5A P.N.U0099766	IJTC5A P.N.U0099808

CART ACCESSORIES

There are some accessories that could be added to the standard cart configuration. These accessories have not been coded, so if they are needed, contact the Chicago Technical Department.

FULL CART COVER

This accessory consists of a top factory welded plate of Gauge 14 (0.075"). Full cart covers are used for loads that are top heavy, or for loads that are storing liquids and have the potential to spill over. They provide a larger surface area for loads to rest on.

Its standard finish is vista green.

Carts with factory welded cart cover plates **cannot** be hot dipped galvanized. The cart cover plate option does not provide a solid surface at the front pallet position, only the carts receive a cover plate.

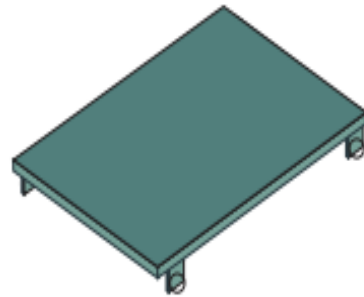

EXTRA CROSS TIE

Extra cross ties are added to reinforce the carts and prevent bending or buckling in a Push Back system. They are welded on the middle of the cart. The standard option has (2) cross ties when pallets are less than or equal to 48" wide and 48" deep. (4) cross ties are standard when pallets are more than 48" wide or 48" deep.

Its standard finish is vista green

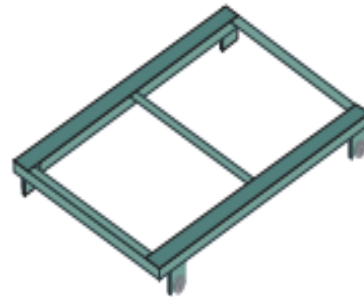

FLOOR LEVEL CARTS

This option allows special carts that change the initial track slope, providing horizontal support surfaces, instead of having the top of carts angled.

For situations where the loads stored in the Push Backs system are top heavy, tall and thin, or are liquids, floor level carts are recommended for preventing loads from knocking over or spilling.

Floor level carts are available for push-back systems with 2, 3 and 4 carts.

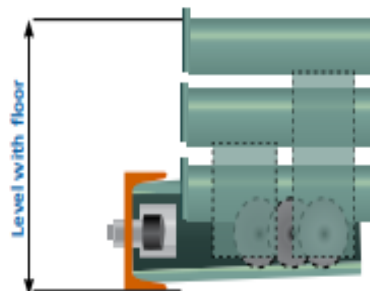

w.w.Cannon, Inc.

Design. Layout. Build. Install.

1-800-442-3061

www.wwcannon.com